



The EDITION 2010
Part Description
DR/SC10000U



AIR TORQUE

PNEUMATISCHE STELLANTRIEBE

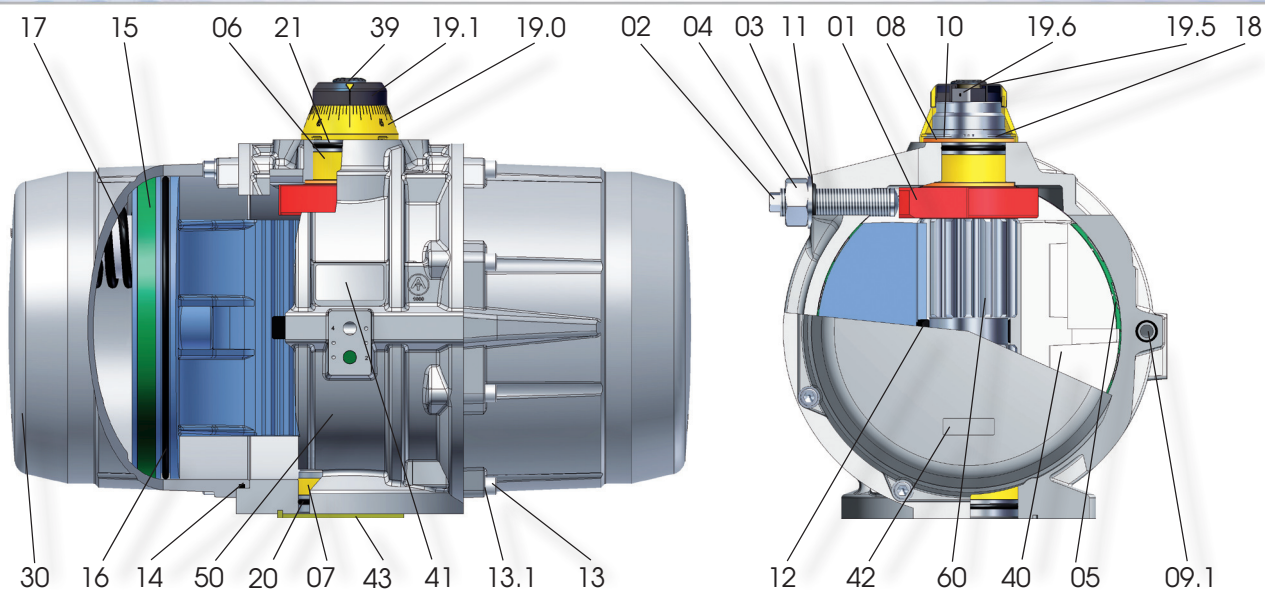

| PART N° | Spare Parts | UNIT Q.TY / NOTE | PART DESCRIPTION | STANDARD MATERIAL (A) (B) |
|---------|-------------|------------------|--|---|
| 01 | | 1 | OCTI-CAM (Stop arrangement) | Nodular Cast Iron, zinc coated |
| 02 | | 2 | ANTI BLOW OUT STOP SCREW | Stainless Steel |
| 03 | | 2 | WASHER | Stainless Steel |
| 04 | | 2 | NUT (Stop screw) | Stainless Steel |
| 05 | ○ | 4 | BEARING (Piston back) | PA46 |
| 06 | ○ | 1 | BEARING (Pinion top) | High-grade polymers |
| 07 | ○ | 1 | BEARING (Pinion bottom) | High-grade polymers |
| 08 | ○ | 2 | THRUST BEARING (Pinion) | PA46 |
| 09.1 | ○ ⊕ | 2 | "O-RING" PLUG | M-NBR |
| 10 | | 1 | THRUST WASHER (Pinion) | Stainless Steel |
| 11 | ○ ⊕ | 2 | "O" RING (Stop screw) | M-NBR |
| 12 | | 2 | PISTON GUIDE | PA66 |
| 13 | | 16 | CAP SCREW (End cap) | Stainless Steel |
| 13.1 | | 16 | WASHER (Cap Screw end cap) | Stainless Steel |
| 14 | ○ ⊕ | 2 | "O" RING (End cap) | M-NBR |
| 15 | ○ | 2 | BEARING (Piston head) | POM |
| 16 | ○ ⊕ | 2 | "O" RING (Piston) | M-NBR |
| 17 | | min.05 max.12 | SPRING (Cartridge) | SiCr Spring alloy Steel epoxy coated |
| 18 | | 1 | SPRING CLIP (Pinion) | Spring Steel, ENP |
| 19.0 | | 1 | GRADUATED RING | PA66+GF(+CB) |
| 19.1 | | 1 | POSITION INDICATOR | PA66+GF+CB |
| 19.5 | | 1 | TOP ADAPTOR | Extruded Aluminium alloy, anodized |
| 19.6 | | 2 | HEX. SOCKET SCREW (Top Adaptor) | Stainless Steel |
| 20 | ○ ⊕ | 1 | "O" RING (Pinion bottom) | M-NBR |
| 21 | ○ ⊕ | 1 | "O" RING (Pinion top) | M-NBR |
| 30 | | 2 | END CAP | Cast Aluminium alloy, anodized and coated |
| 39 | | 1 | CAP SCREW (Indicator) | PA66+GF+CB |
| 39.1 | | 1 | WASHER (Indicator) | Stainless Steel |
| 40 | | 2 | PISTON | Cast Aluminium alloy, anodized |
| 41 | | 1 | ACTUATOR IDENTIFICATION LABEL | Polyester-Silver |
| 42 | | 2 | END CAP LABEL | Polyester-Silver |
| 43 | | 1 | SPIGOT (Only on request) | Extruded Aluminium alloy, anodized |
| 50 | | 1 | BODY | Cast Aluminium alloy, coated |
| 60 | | 1 | DRIVE SHAFT | Extruded Aluminium alloy, anodized |
| 60.1 | | 1 | only f. prot. level E / EC INTEGRAL DRIVE SHAFT | Stainless Steel, ENP |

○ Parts included in Complete spare parts kit ⊕ Parts included in „O“ ring spare parts kit