



Pneumatic Actuators with interesting Innovations	1
Principle of Function with sizing examples	
The principle of double acting actuators	2
The principle of single acting actuators	
The AIR TORQUE – Part turn Actuators with technical Details	
Technical Description Protection A - B - D - E - P - EC - Stainless Steel	3
Technical Data of the EDITION 2010 in overview with technical details	4
Technical Data DR/SC00010U - DR/SC10000U	5
Data sheets Actuators 90° • Part description • Data sheet stainless steel • Data sheet spare parts Air consumption	
Special actuators	6
Turning range 120°-135°-180° • 3-position 90°/180° • Speed control • Fail safe position SC 180° (spring return) • Extreme low temperature • Operating media water	
Accessories	7
Limit switch kit • Multifunction indicator • Adaptors • Centerings • Block and Lock Travel stop adjustment • Indicator for switches	
The Automation with technical Details	8
In Progress	
Manual and Maintenance	9
Manual Maintenance	
The electric Actuators (see separate data sheets) ER Premier, ER Plus, VR, VT, VRX, VSX	10
Company Profile and References	11
Appendix	12
Certificate of Approval • GOST Classification of Ships and Mobile Off Shore Units	
More Information ...	
info@airtorque.de • www.airtorque.de	



We introduce ourselves...
Pneumatic
Part Turn Actuators



AIR TORQUE
PNEUMATISCHE STELLANTRIEBE

Air Torque GmbH - 4th Generation pneumatic part turn actuators

Innovations for the future with new and intelligent highlights!

The company AIR TORQUE GmbH, located in Ettlingen, near to the Black Forest, is your technical partner for pneumatic and electric actuators.

The development and production of the pneumatic actuators is done in accordance with the practicable standards, for example the ISO 5211, DIN 3337, VDI/VDE 3845 or the NF E29-409 considering the ISO 9001.



Our team in the sales department, the project planning and in the assemblage assures to you a perfect support and a high quality standard.

To guarantee the daily deliveries we maintain the world-wide biggest stock with Air Torque part turn actuators.



Additional we are to meet online at www.airtorque.de anytime.

Here we provide beside the technical informations a large download area with documentation.

AIR TORQUE part turn actuators of the 4. Generation:

Interesting news and a lot of technical developments combine best practice now with the requirements of the future and fulfil the newest demands of the ISO 5211 yet!

- ① **Body** - The Aluminium body with the appealing 'New Edge Design' is inside and outside complete coated with ALODUR.

Advantages

of the ALODUR coating:
extremely abrasion resistant,
low surface roughness, optimal resistance

- ② **External stroke adjustment** - a great saving of time is achieved, when mounting the actuator on the valve, through the service friendly adjustment of both end positions with the precise cam system. The rotation angle is easily changeable with a special cam, f.e. for 0°-15° and 75°-90°. Safety for emergency cases is possible through blocking of the actuator. This new feature can be used by simply changing the screw into a longer one. All adjustments of the end positions are possible service friendly without disassembling.

- ③ **Multifunction indicator** - the position of the multifunction indicator is quick adapted for a parallel or 45° position of the square as well as for along or across to the pipe mounted actuator positions.

The direct mounting - through exchange of the yellow inserts the multifunction indicator is suitable as cam for the direct mounting (mechanic, inductive).

- ④ **The connections** - ISO 5211, DIN 3337 (F03-F25), VDI/VDE 3845 (Size 0 to 4) ISO 1 (CNOMO) and NAMUR for flexible usability and exchangeability.

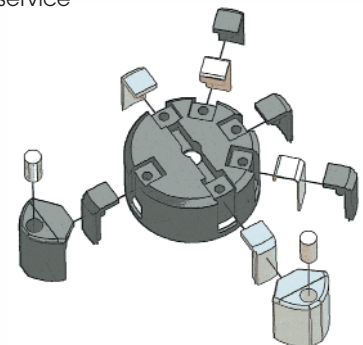
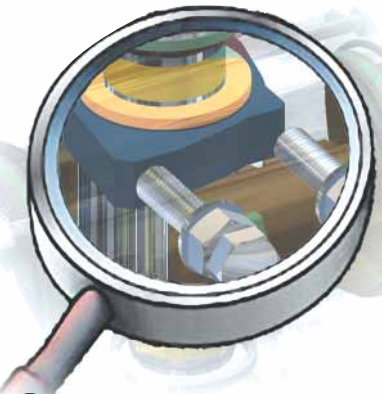
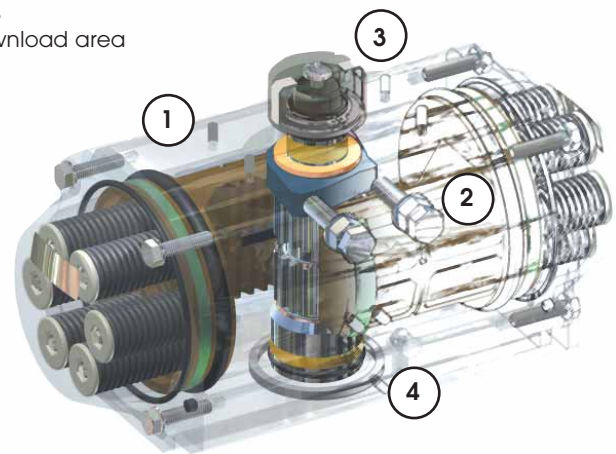



We introduce ourselves...
 Pneumatic
 Part Turn Actuators



AIR TORQUE
 PNEUMATISCHE STELLANTRIEBE

The driveshaft - square - flathead - key - star

A more flexible construction is obtained through the possibility of free adjustment of the driveshaft in 45°-steps (square on the bottom). With a rotation of the drive shaft the requested position can be realized. For correct position indication the plug of the indicator (drive shaft top) is designed as an octagon, so the position indicator also can be mounted in 45°-steps.

Optional a flathead, key connection or a star is available (for the star the lower usable torque is to consider).

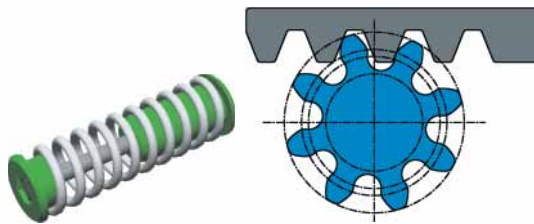
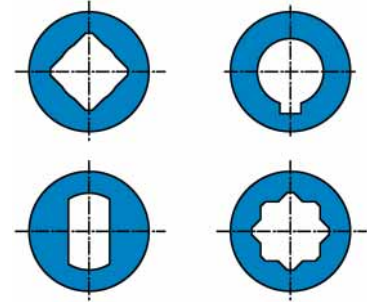

Technical details

The tooth profile, and so the way of force, for the used rack and pinion principle was optimized through the involute gearing.

Additional it is possible to adjust the torque through the reliable spring cartridges, made with high quality spring steel, according to the requirements.

The new multifunction indicator for 4th Generation actuators (2. Line).

The multifunction indicator

The new indicator is suitable for 45° or 90° position (s. a.). A visual indication is realized through coloured inserts (white) in the (red) indicator. The inserts are variable to fit. The indicator has a VDI/VDE-interface. So mostly every standard attachment can be mounted without problems.

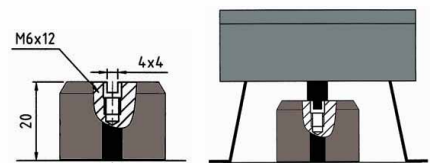

The direct mounting

Through exchange of the standard inserts with metal inserts the multifunction indicator can be quick and easy changed for direct mounting.

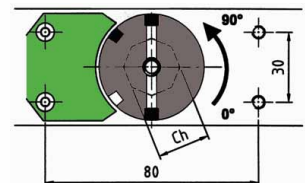

With this new Multifunctionindicator nearly the most of the possibilities with common switches are easily and variable to mount. And all this with the standard cams !

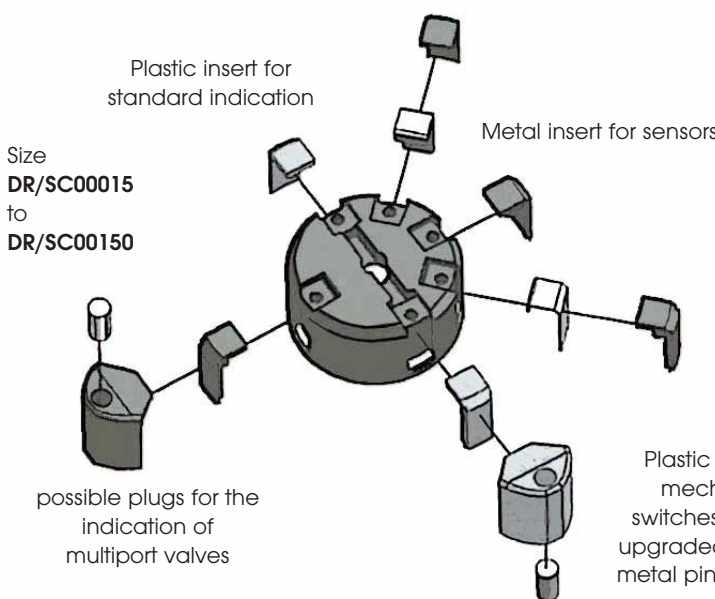

Example for mechanical or IFM sensors



Example for proximity switches (P+F, TURCK etc...)



Example for multipoint valve indication



Note: Indicators for the actuator sizes DR/SC00220 to DR/SC05000 Ø85 / Ø115 see page 0706/0707 ->



The principle of the double acting actuator

If the port '2' is under pressure and port '4' evacuated, the both pistons are moving into the endpositions and a turning of the drive shaft is the result (a turning of the drive shaft in its opposite is possible through a turned mounting of the pistons -> type DL).

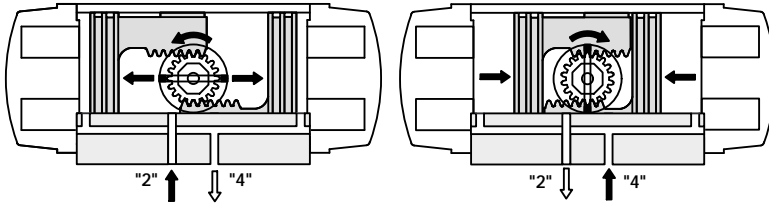

Fig. DR02: Top view and principle of a double acting actuator under pressure

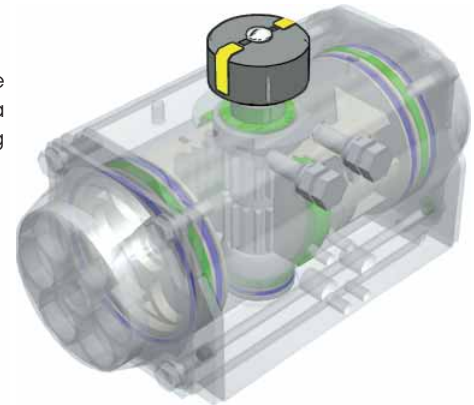

Fig. DR01:
Principle of a double acting actuator

If the port '4' is under pressure and the port '2' de-aerated, the pistons are moving into the middle position. This also has as result a turning of the drive shaft (a turning of the drive shaft in its opposite is possible through a turned mounting of the pistons).

With rack and pinion construction the output torque of an actuator is obtained by multiplying the piston force (given by air supply pressure) by the pitch shaft radius (lever arm) as shown in fig. DR03 less the force lost for friction (efficiency). Because of this concept, the output torque is linear as shown in the diagram DR04 in both clockwise and counterclockwise rotation.

The suggested safety factor for double acting actuators in normal working conditions is 15-20%.

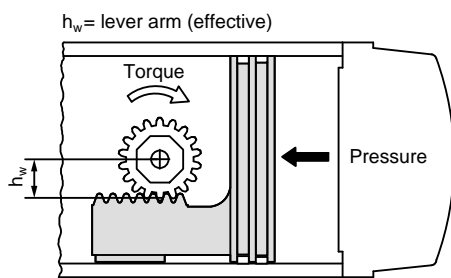

Fig. DR03: Top view of a double acting actuator under pressure

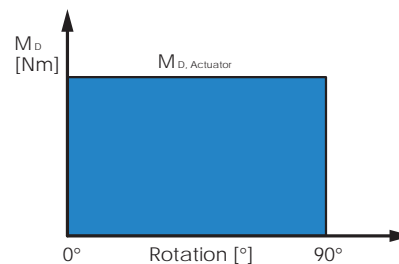

Fig. DR04: Principle of the torque (double acting)

Sizing example for double acting actuator (data see datasheet):

Published butterfly valve torque	= 40 Nm
Safety factor	= 40 Nm + 20 % = 48 Nm
Air supply pressure available	= 5 bar

The double acting AT actuator that produces a minimum of 48 Nm at 5 bar is the DR60.

Fig. DR05:
Principle of the sizing a double-acting actuator

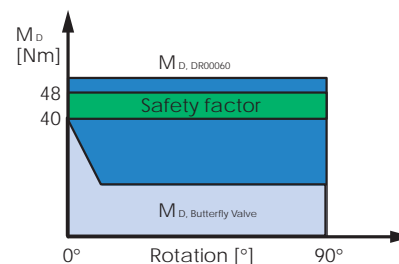



Principle of Single Acting Actuators (Spring Return)

If the port '2' is under pressure and port '4' evacuated, the both pistons are moving into the endpositions and compress the springs - result is a turning of the drive shaft (a turning of the drive shaft in its opposite is possible through a turned mounting of the pistons -> type SO).

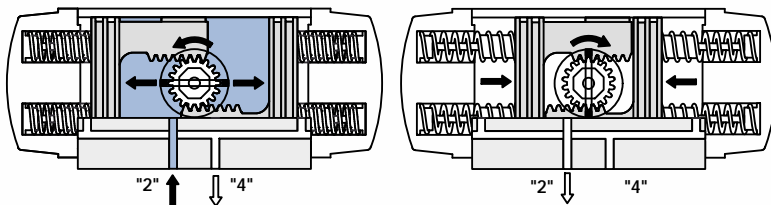

Fig. SC02: Top view and principle of a single acting actuator under spring pressure

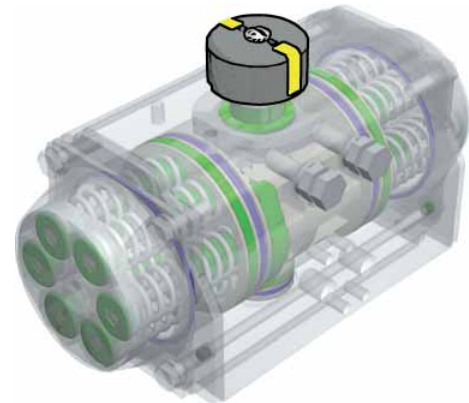

Fig. SC01:
Principle of a single acting actuator

By the spring force a fail-safe position by air or electricity loss is guaranteed.

In spring return applications the output torque is obtained in two different operations. Each operation produces two different values in relation to the stroke position (0° or 90°). For spring return actuators the output torque is produced by multiplying the force (air or springs acting on the pistons) by the lever arm.

First case:

The output torque is generated by air supply pressure at port '2' after compressing the springs, called 'output torque air stroke'. In this case air forces the pistons from the 0° to the 90° position and consequently the torque starts from a high value and during the stroke it constantly decreases until 90° due to the natural force that springs generate (oppose) when they are compressed (see diagram SC04).

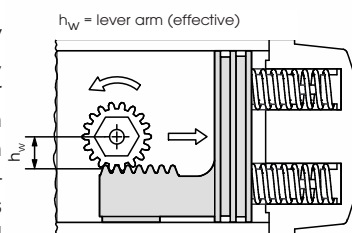

Fig. SC03:
Top view of a single-acting actuator

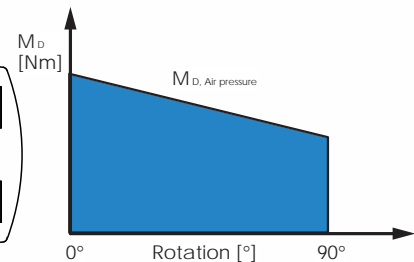

Diagram SC04:
Principle of the air torque

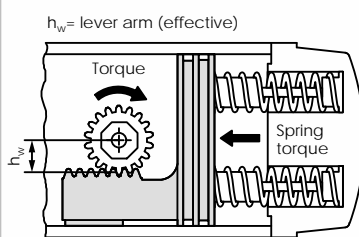

Fig. SC05:
Top view of a single acting actuator

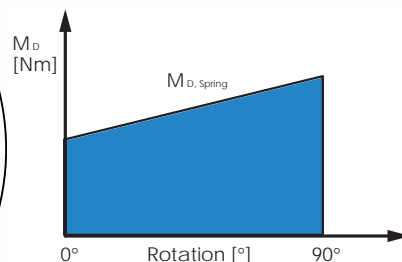

Diagram SC06:
Principle of the spring torque

Second case:

The output torque is generated by the force that springs release onto the pistons when air fails, called 'output torque spring stroke'. In this case the torque, starting from the 90° position, constantly decreases until 0° because of springs extending (see diagram SC06).

AT spring return actuators are designed to produce a balanced torque in the two conditions explained above when the number of springs per side is equal to the air pressure supply (4 bar - 4 springs each side) as shown in the diagram SC07. For certain applications it is possible to achieve (where desired), the unbalanced torque, as shown in diagram SC08, by changing the relation between the number of springs per side and air pressure supply in bar (for example 6 springs and 5,5 bar or vice versa).

In spring return applications two conditions can be achieved: air failure to close or failure to open. The suggested safety factor for spring return actuators in normal working conditions is 20-25%.



Sizing of a single acting actuator (Data see datasheet):

1. Spring to close (when air fails):

Published ball valve torque	= 80 Nm
Safety factor	= 80 Nm + 20 % = 96 Nm
Air supply pressure available	= 5 bar

The spring return AT actuator selected is the SC300 - 5, because it produces the following values:

Spring stroke 0°	= 105 Nm
Spring stroke 90°	= 165 Nm

Air stroke 0°	= 172 Nm
Air stroke 90°	= 112 Nm

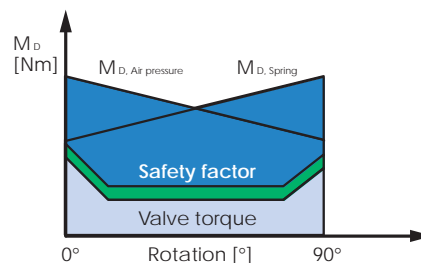

Diagram SC07: Principle of balanced torque

2. Spring to open with unbalanced torque (when air fails):

Published ball valve torque	= 45 Nm
Safety factor	= 45 Nm + 20 % = 54 Nm
Air supply pressure available	= 5,5 bar

The spring return AT actuator selected is the SC150 - 5, because it produces the following values:

Spring stroke 0°	= 50,7 Nm
Spring stroke 90°	= 78,8 Nm

Air stroke 0°	= 95,6 Nm
Air stroke 90°	= 67,5 Nm

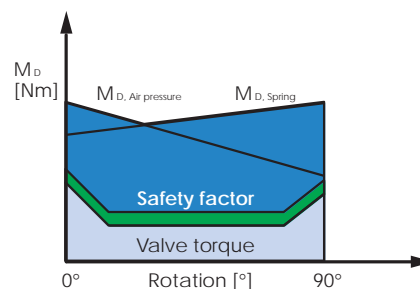
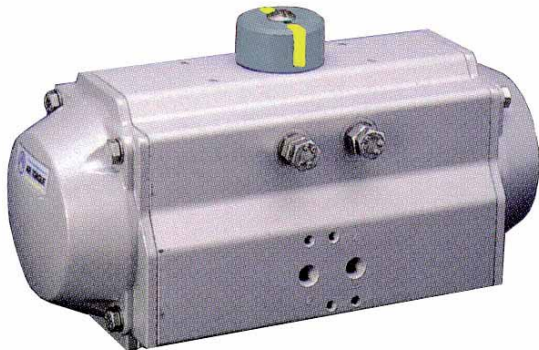

Diagram SC08: Principle of unbalanced torque



Rack and pinion actuator with constant torque version 'A' throughout the entire output rotation with convincing advantages



The body is ALODUR coated, inside as well as outside. The end caps are chromatinized and coated with light-grey polyester. The coating is abrasion-free and is used for standard industrial purposes. The ALODUR-coating has compared with the common hard anodizing the advantage of a better surface roughness with nearly the same strength, by a better stability.

External serviceable travel stops for open and close position allow a fine adjustment of $\pm 4^\circ$. This special feature eliminates alignment problems due to a clearance of connections between the stem of the valve adaptor and the shaft of the actuator.

Due to a triple bearing of the piston all actuators have a constant torque, even under high load. Beside the guides on the outside of the piston there is an additional guide inside which absorbs the cross load through the integrated support at the drive shaft.

The drive shaft is held in position by two bearings, one at the top of the pinion, one at the bottom. These guarantee less friction and abrasion-free operation. Due to the special design of the bearings at the shoulders of the piston, the drive shaft is blowout proof and fulfills the hard US-standards for product liability.

The drive shaft has a 25-30 μm electroless nickel coating.

The bearings are temperature resistant to 155°C. Because of an internal retaining shoulder the bearings are blowout safe.

The maintenance free springs allow a safe and simple assembly and disassembly. The adaptation of the AT - actuators to your working conditions with the recommended pneumatic pressure can so be arranged. The conversion of a double acting to a spring return actuator can be easily managed. Only the necessary springs have to be mounted. This advantage of AT - actuators reduces stocking costs significantly.

Silicon free:

All actuators are silicon free according to the automobile industry recommendations.

Exception: High and low temperature actuators

Serial inspection:

Each actuator has to pass a comprehensive serial inspection with e.g. a tightness / density check and a torque check. After passing the inspection the actuator is given a serial number according to ISO 9001.

Test Certificate:

Salt spray test: no. SAC/655/98
Kesternich test: no. SAC/299/98

Approval:

Classification of ships: DET NORSKE Nr. P-12465
GOST: no. 7435773, PPC 00-26447

Protection	Parts and Protection				suitable for	not recommended for
	Body	End-Caps	Drive Shaft	Pistons		
Material	EN AW 6063	GD-ALSi8.5Cu3.5Fe	C22	GD-ALSi8.5Cu3.5Fe	general service	caustic soda, all strong acids or basic solutions
Description	ALODUR	chromatinized + Polyester coated	Carbon steel ENP	anodized, black		
Coating	30 - 35 μm	80 - 90 μm	25 - 30 μm	15 - 20 μm		
Colour	light grey	light grey, Ral 9007		black		
Process	This coating is achieved through a special method, which uses a special surface treatment with brushing and sandblasting followed by an electrochemical oxidation of the aluminium surface.					
Advantages	Good corrosion resistance, very high surface hardness for good abrasion resistance in connection with the standard hard anodization the inside surface roughness was reduced about 40%. The outcome of this is lower friction in combination with a higher sealing lifetime.					



Rack and pinion actuator with constant torque version 'B' throughout the entire output rotation with convincing advantages

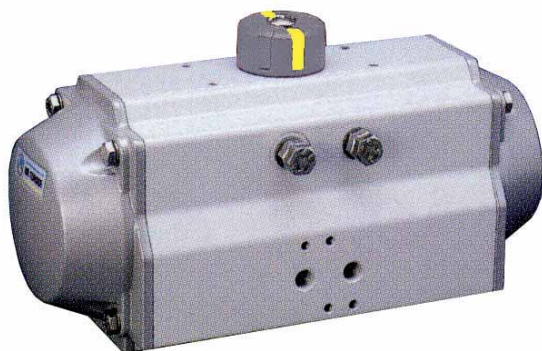

The body is hard anodized, inside as well as outside. Additional the body is coated with PTFE. The end caps are chromitized and coated with light-grey polyester. The coating resists light acids and basic solutions.

External serviceable travel stops for open and close position allow a fine adjustment of $\pm 4^\circ$. This special feature eliminates alignment problems due to a clearance of connections between the stem of the valve adaptor and the shaft of the actuator.

Due to a triple bearing of the piston all actuators have a constant torque, even under high load. Beside the guides on the outside of the piston there is an additional guide inside which absorbs the cross load through the integrated support at the drive shaft.

The drive shaft is held in position by two bearings, one at the top of the pinion, one at the bottom. These guarantee less friction and abrasion-free operation. Due to the special design of the bearings at the shoulders of the piston, the drive shaft is blowout proof and fulfills the hard US-standards for product liability.

The drive shaft has a 25-30 μm electroless nickel coating.

The bearings are temperature resistant to 155°C. Because of an internal retaining shoulder the bearings are blowout safe.

The maintenance free springs allow a safe and simple assembly and disassembly. The adaptation of the AT - actuators to your working conditions with the recommended pneumatic pressure can so be arranged. The conversion of a double acting to a spring return actuator can be easily managed. Only the necessary springs have to be mounted. This advantage of AT - actuators reduces stocking costs significantly.

Silicon free:

All actuators are silicon free according to the automobile industry recommendations.

Exception: High and low temperature actuators

Serial inspection:

Each actuator has to pass a comprehensive serial inspection with e.g. a tightness / density check and a torque check. After passing the inspection the actuator is given a serial number according to ISO 9001.

Test certificate:

Salt spray test: Nr. SAC/656/98
Kesternich test: Nr. SAC/300/98

Approval:

Classification of ships: DET NORSKE Nr. P-12465
GOST: no. 7435773, PPC 00-26447

Protection	Parts and Protection				suitable for	not recommended for
	Body	End-Caps	Drive Shaft	Pistons		
Material	EN AW 6063	GD-AISI8.5Cu3.5Fe	C22	GD-AISI8.5Cu3.5Fe	general service Caustic Soda in low concentration	chlorine, sulphuric and salted environment nitric acid
Description	ALODUR + PTFE coated	chromitized + Polyester coated	Carbon steel ENP	anodized, black		
Coating	PTFE 25 - 30 μm	80 - 90 μm	25 - 30 μm	15 - 20 μm		
Colour	light grey	light grey, Ral 9007		black		
Process	This coating is achieved through a special method, which uses a special surface treatment with brushing and sandblasting followed by an electrochemical oxidation of the aluminium surface. Add. the body is PTFE coated.					
Advantages	Optimal corrosion resistance, through PTFE coating highest chemical resistance, PTFE has a wide range of temperature application. End cap Polyester coated, therefore more cost-efficient than D-version.					



Rack and pinion actuator with constant torque version 'D' throughout the entire output rotation with convincing advantages

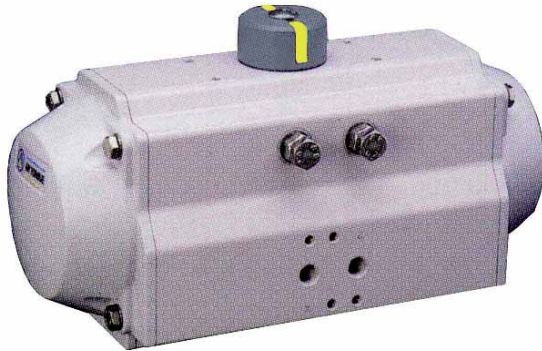

The body is hard anodized, inside as well as outside. Additionally the body is coated with PTFE. The end caps are chromated and also coated with PTFE. The coating resists acids and basic solutions.

External serviceable travel stops for open and close position allow a fine adjustment of $\pm 4^\circ$. This special feature eliminates alignment problems due to a clearance of connections between the stem of the valve adaptor and the shaft of the actuator.

Due to a triple bearing of the piston all actuators have a constant torque, even under high load. Beside the guides on the outside of the piston there is an additional guide inside which absorbs the cross load through the integrated support at the drive shaft.

The drive shaft is held in position by two bearings, one at the top of the pinion, one at the bottom. These guarantee less friction and abrasion-free operation. Due to the special design of the bearings at the shoulders of the piston, the drive shaft is blowout proof and fulfills the hard US-standards for product liability.

The drive shaft has a 25-30 μm electroless nickel coating.

The bearings are temperature resistant to 155°C. Because of an internal retaining shoulder the bearings are blowout safe.

The maintenance free springs allow a safe and simple assembly and disassembly. The adaptation of the AT - actuators to your working conditions with the recommended pneumatic pressure can so be arranged. The conversion of a double acting to a spring return actuator can be easily managed. Only the necessary springs have to be mounted. This advantage of AT - actuators reduces stocking costs significantly.

Silicon free:

All actuators are silicon free according to the automobile industry recommendations.

Exception: High and low temperature actuators

Serial inspection:

Each actuator has to pass a comprehensive serial inspection with e.g. a tightness / density check and a torque check. After passing the inspection the actuator is given a serial number according to ISO 9001.

Test certificate:

Salt spray test: no. SAC/890/96
Kesternich test: no. SAC/896/96

Approval:

Classification of ships: DET NORSKE Nr. P-12465
GOST: no. 7435773, PPC 00-26447

Protection	Parts and Protection				suitable for	not recommended for
	Body	End-Caps	Drive Shaft	Pistons		
Material	EN AW 6063	GD-AISI8.5Cu3.5Fe	C22	GD-AISI8.5Cu3.5Fe	general service, acids or basic solutions in low concentration	nitric acid and all painting solutions
Description	ALODUR + PTFE resin coated	chromatized + special PTFE	Carbon steel ENP	anodized, black		
Coating	50 - 55 μm	80 - 90 μm	25 - 30 μm	15 - 20 μm		
Colour	light grey	light grey		black		
Process	This coating is achieved through a special method, which uses a special surface treatment with brushing and sandblasting followed by an electrochemical oxidation of the aluminium surface. Add. the body is PTFE coated.					
Advantages	Optimal corrosion resistance, through PTFE coating highest chemical resistance, PTFE has a wide range of temperature application. In connection with the standard hard anodation the inside surface roughness was reduced about 40%.					



Rack and pinion actuator with constant torque version 'E' throughout the entire output rotation with convincing advantages



The body is hard anodized, inside as well as outside. Additional the body is coated with PTFE. The end caps are chromitized and also coated with PTFE. The coating resists acids and basic solutions.

External serviceable travel stops for open and close position allow a fine adjustment of $\pm 4^\circ$. This special feature eliminates alignment problems due to a clearance of connections between the stem of the valve adaptor and the shaft of the actuator.

Due to a triple bearing of the piston all actuators have a constant torque, even under high load. Beside the guides on the outside of the piston there is an additional guide inside which absorbs the cross load through the integrated support at the drive shaft.

The drive shaft is held in position by two bearings, one at the top of the pinion, one at the bottom. These guarantee less friction and abrasion-free operation. Due to the special design of the bearings at the shoulders of the piston, the drive shaft is blowout proof and fulfills the hard US-standards for product liability.

The material of the drive shaft is stainless steel.

The bearings are temperature resistant to 155°C. Because of an internal retaining shoulder the bearings are blowout safe.

The maintenance free springs allow a safe and simple assembly and disassembly. The adaptation of the AT - actuators to your working conditions with the recommended pneumatic pressure can so be arranged. The conversion of a double acting to a spring return actuator can be easily managed. Only the necessary springs have to be mounted. This advantage of AT - actuators reduces stocking costs significantly.

Silicon free:

All actuators are silicon free according to the automobile industry recommendations.
Exception: High and low temperature actuators

Serial inspection:

Each actuator has to pass a comprehensive serial inspection with e.g. a tightness / density check and a torque check. After passing the inspection the actuator is given a serial number according to ISO 9001.

Test Certificate:

Salt spray test: no. SAC/886/96
Kesternich test: no. SAC/897/96

Approval:

Classification of ships: DET NORSKE Nr. P-12465
GOST: no. 7435773, PPC 00-26447

Protection	Parts and Protection				suitable for
	Body	End-Caps	Drive Shaft	Pistons	
Material	EN AW 6063	GD-AISI8.5Cu3.5Fe	S.S. 303	GD-AISI8.5Cu3.5Fe	through S.S. shaft good resistance against strong environmental influences acids or basic solutions
Description	ALODUR + PTFE resin coated	chromitized + special PTFE	stainless steel	anodized, black	
Coating	PTFE 25 - 30 μm	80 - 90 μm		15 - 20 μm	
Colour	light grey	light grey		black	
Process	This coating is achieved through a special method, which uses a special surface treatment with brushing and sandblasting followed by an electrochemical oxidation of the aluminium surface. Add. the body is PTFE coated.				
Advantages	Optimal corrosion resistance, through PTFE coating highest chemical resistance, PTFE has a wide range of temperature application. With stainless steel drive shaft optimal chemical resistance.				



Rack and pinion actuator with constant torque version 'P' throughout the entire output rotation with convincing advantages

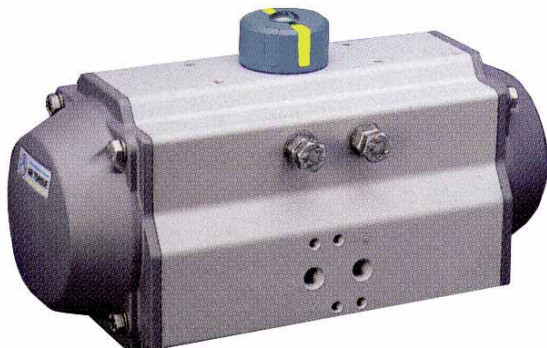

The body is special hard anodized (ALODUR), inside as well as outside. The end caps are special hard anodized too. The coating is abrasion-free and resists against different aggressive medias.

External serviceable travel stops for open and close position allow a fine adjustment of $\pm 4^\circ$. This special feature eliminates alignment problems due to a clearance of connections between the stem of the valve adaptor and the shaft of the actuator.

Due to a triple bearing of the piston all actuators have a constant torque, even under high load. Beside the guides on the outside of the piston there is an additional guide inside which absorbs the cross load through the integrated support at the drive shaft.

The drive shaft is held in position by two bearings, one at the top of the pinion, one at the bottom. These guarantee less friction and abrasion-free operation. Due to the special design of the bearings at the shoulders of the piston, the drive shaft is blowout proof and fulfills the hard US-standards for product liability.

The drive shaft has a 25-30 μm electroless nickel coating.

The bearings are temperature resistant to 155°C. Because of an internal retaining shoulder the bearings are blowout safe.

The maintenance free springs allow a safe and simple assembly and disassembly. The adaptation of the AT - actuators to your working conditions with the recommended pneumatic pressure can so be arranged. The conversion of a double acting to a spring return actuator can be easily managed. Only the necessary springs have to be mounted. This advantage of AT - actuators reduces stocking costs significantly.

Silicon free:

All actuators are silicon free according to the automobile industry recommendations.

Exception: High and low temperature actuators

Serial inspection:

Each actuator has to pass a comprehensive serial inspection with e.g. a tightness / density check and a torque check. After passing the inspection the actuator is given a serial number according to ISO 9001.

Test certificate:

Salt spray test: no. SAC/304/98
Kesternich test: no. SAC/301/98

Approval:

Classification of ships: DET NORSKE Nr. P-12465
GOST: no. 7435773, PPC 00-26447

Protection	Parts and Protection				suitable for	not recommended for
	Body	End-Caps	Drive Shaft	Pistons		
Material	EN AW 6063	GD-AISI8.5Cu3.5Fe	C22	GD-AISI8.5Cu3.5Fe	General services, low salted environment	Caustic soda, all strong acids or basic solutions
Description	ALODUR - coated	hard anodized	ENP	anodized, black		
Coating	30 - 35 μm	30 - 35 μm	25 - 30 μm	15 - 20 μm		
Colour	grey silver	grey		black		
Process	ALODUR is a special coating treatment, which is created in connection with a electro-chemical reaction of the Al base material. This ALODUR coating is generated in two different coating treatments.					
Advantages	Comparable to the good surface hardness like the hard anodizing. Therefore high life time. Very good corrosion resistance in general service and salted environment. Through the lower layer thickness compared with hard anodizing a lower friction in connection with a higher sealing life time is achieved.					



4th Generation

Stainless Steel Actuators



AIR TORQUE
PNEUMATISCHE STELLANTRIEBE

FORGED STAINLESS STEEL Rack and Pinion Actuator

Air Torque has developed a new line of forged stainless steel actuators with material traceability. This new line of stainless steel actuators has been designed to be used in corrosive environment by using forged high quality stainless steel body material in A 182 F316/ EN 10088/3 1.4401.

Appropriate Field of applications:

- Food Industry
- Pharmaceutical
- Sanitary
- Cosmetics
- Enology
- Marine and Offshore Plant
- Corrosive environments

These actuators are manufactured in Double acting and Spring Return versions. The stainless steel actuators are also available with optional polished surface, particularly for Sanitary and Pharmaceutical applications.



FEATURES AND BENEFITS

The new line of stainless steel actuators offers a lot of innovative design features and benefits like:

- High performance
- Full compliance with worldwide latest specifications
- Simple, compact and modern shape to avoid cavity contamination and corrosive deposit build up
- Namur air connection interface for easy mounting of solenoid valves
- Namur mounting dimension on top for simply ancillary installation
- Full conformance to the latest specifications: ISO 5211 and DIN 3337
- Two independent external travel stop adjustments, of $\pm 4^\circ$ in both, open and close positions
- Dual piston rack and pinion design for compact construction, symmetric mounting position, long life cycle and fast operation. Reverse rotation can be performed on site by simply inverting the pistons
- Modular preloaded spring cartridge design. With coated springs for simple versatile range, greater safety and corrosion resistance

OPTIONS

1. Polished surface particularly for Sanitary and Pharmaceutical applications.
2. Stainless steel pistons and spring cartridges.
3. Maximum supply pressure up to 15 bar when supplied with stainless steel pistons.

For technical data see chapter 6, page 0619e and 0620e.



Coating specifications for EC version actuators

RAL 7046



suitable for

- General service
- Acid or basic solutions in low concentration

not suitable for:

- Nitric acid
- N-methyle pirolidone (Solvent)

Parts and coating specifications:

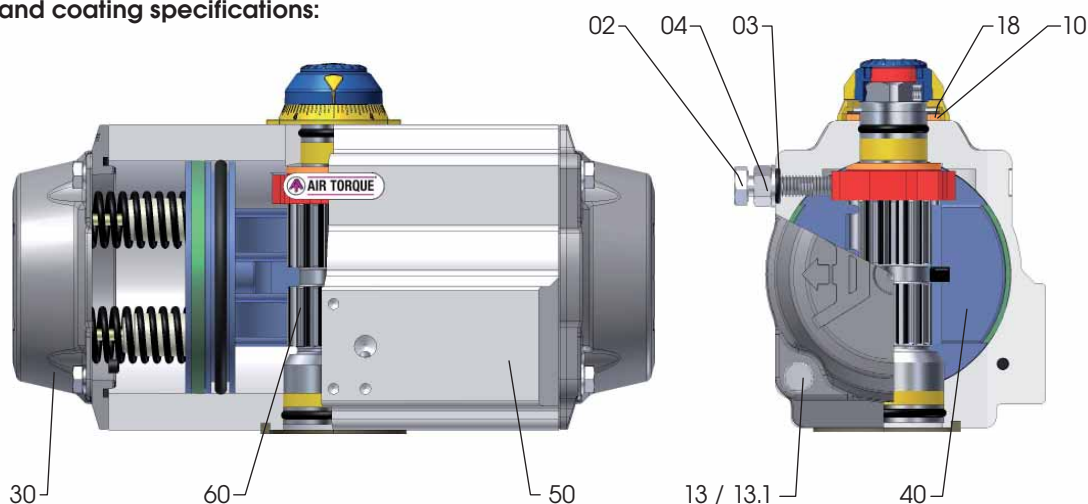

Part No.	Quantity / Note	Part Description	Standard Material	Corrosion Protection	Coating Thickness in μ	Standard Colour
02	2 not for DR/SC00010U	Stop cap screw	Stainless Steel A4 70 (ISO 3506)	-	-	-
03	2 not for DR/SC00010U	Washer	Stainless Steel A4 (ISO 3506)	-	-	-
04	2 not for DR/SC00010U	Nut (Stop screw)	Stainless Steel A4 70 (ISO 3506)	-	-	-
10	1 for DR/SC00010U-5000U	Thrust Washer (Pinion)	Stainless Steel AISI 304	-	-	-
13	8/12/16 for DR/SC00010U-5000U	Cap Screw (End cap)	Stainless Steel A4 70 (ISO 3506)	-	-	-
13.1	16 only for DR/SC10000U	Washer (Cap Screw end cap)	Stainless Steel A4 70 (ISO 3506)	-	-	-
18	1 for DR/SC00010U-10000U	Spring clip (Pinion)	Stainless Steel AISI 302	-	-	-
30	2 for DR/SC00010U-5000U only for DR/SC10000U	End cap	Pressure Die Cast Aluminium alloy	Anodized + • 1 st C. Primer coating • 2 nd C. Epoxy coating	30 - 40	RAL7046
			Cast Aluminium alloy		30 - 40	
40	2 for DR/SC00010U - 5000U only for DR/SC10000U	Piston	Pressure Die Cast Aluminium alloy	Anodized	10 - 15	Black
			Cast Aluminium alloy			
50	1 for DR/SC00010U-4000U for DR/SC5000U and 10000U	Body	Extruded Aluminium alloy	Anodized + • 1 st C. Primer coating • 2 nd C. Epoxy coating	25 5 - 10 40 - 70	RAL7046
			Cast Aluminium alloy		15 - 20 30 - 40 40 - 60	
60	1 for DR/SC00010U-10000U	Drive shaft (With Integral Top)	Stainless Steel AISI 316 (1.4401)	E.N.P.	20 - 25	-

Note: For all other part descriptions and material see technical data sheet of the proper model

Test certificate:

Salt spray test: Nr. SAC/892/96

Kesternich test: Nr. SAC/895/96

Approval:

Classification of ships:

DET NORSKE Nr. P-12465

GOST:

Nr. 7435773, PPC 00-26447



Protection and Serviceability

Representation	Type	Part and Protection				suitable for
		Body	End Caps	Drive Shaft	Pistons	
	A	ALODUR	chromatized and polyester coated	carbon steel ENP	normal anodized	general service
	Coating Colour	30 - 35 µm bright S.S.	80 - 90 µm S.S. Ral 9007	25 - 30 µm	15 - 20 µm black	
	B	ALODUR + PTFE coating	chromatized and polyester coated	carbon steel ENP	normal anodized	general service, acid or basic solutions in low concentration
	Coating Colour	30-35/25-30 µm light grey	80 - 90 µm S.S. Ral 9007	25 - 30 µm	15 - 20 µm black	
	D	ALODUR +PTFE coating	chromatized and PTFE coating	carbon steel ENP	normal anodized	aggressive environment, acid or basic solutions
	Coating Colour	30-35/25-30 µm light grey	80 - 90 µm light grey	25 - 30 µm	15 - 20 µm black	
	E	ALODUR +PTFE coating	chromatized and PTFE coating	stainless steel	normal anodized	acid or basic solutions, seawater
	Coating Colour	30-35/25-30 µm light grey	80 - 90 µm light grey		15 - 20 µm black	
	P	ALODUR	resin impregnated + hard anodized	carbon steel ENP	normal anodized	acid or basic solutions, seawater
	Coating Colour	30-35 µm bright S.S.	30 - 35 µm bright S.S.	25 - 30 µm	15 - 20 µm black	
	EC	ALODUR+ EPOXY	chromatiert + EPOXY	Edelstahl	normal anodized	general service, acid or basic solutions in low concentration
	Coating Colour	80-95 µm blue grey	80 - 95 µm blue grey		15 - 20 µm black	

Conditions of Usage

DR/SC05000 only available in protection A or P

Air Supply	Temperature Range according to Design	max. press.	Turning Range ±4° adjustable	
filtered, lubricated or dry air, non corrosive media, Dp -20°C (Dew Point) (Dp min. 10°C < T _{arec}), particle size < 30 µm	standard	8 bar	90° 120°-135°-180° o.r.	
	low temperature			-20°C to +80°C
	high temperature			-40°C to +80°C -15°C to +150°C

DR	Output Torque for Double Acting Actuators in Nm												
	2,5bar	3bar	3,5bar	4bar	4,2 bar	4,5bar	5bar	5,5bar	6bar	6,5bar	7bar	7,5bar	8bar
00010U	6,0	7,2	8,4	9,6	10,1	10,8	12,0	13,2	14,4	15,6	16,8	18,0	19,1
00015U	8,3	10	11,6	13,3	14	15	16,6	18,3	19,9	21,6	23,3	24,9	26,6
00030U	14,7	17,6	20,5	23,5	24,6	26,4	29,3	32	35,2	38,1	41	44	46,9
00060U	29,1	34,9	40,7	46,5	48,9	52,4	58,2	64	69,8	75,6	81,4	87,3	93,1
00100U	45,8	54,9	64,1	73,2	76,9	82,4	91,5	101	110	120	128	138	146
00150U	66,5	79,8	93,1	106	112	120	133	146	160	173	186	199	213
00220U	107	129	150	172	181	193	215	236	258	279	301	322	344
00300U	138	166	194	222	233	249	277	305	332	360	388	415	443
00450U	217	261	304	348	365	391	435	478	522	565	609	652	696
00600U	284	340	397	454	477	511	567	624	681	737	794	851	908
00900U	383	459	536	613	643	689	766	842	919	996	1072	1149	1225
01200U	532	638	745	851	893	957	1064	1170	1276	1383	1489	1595	1702
02000U	893	1072	1251	1430	1501	1608	1787	1966	2144	2318	2502	2684	2859
03000U	1297	1556	1815	2075	2179	2334	2594	2853	3112	3372	3631	3890	4150
04000U	1795	2154	2513	2872	3015	3231	3590	3949	4308	4667	5026	5400	5744
05000U	2252	2703	3153	3604	3784	4054	4504	4955	5405	5855	6306	6756	7207
10000U	4169	5003	5837	6671	7005	7505	8339	9173	10007	10841	11674		

example of layout DR900 at 5,5bar air supply -> 842Nm output torque



SC	SP/S	2,5bar		3bar		3,5bar		4bar		4,2bar		Sp. torque		SP/S	4,2bar		4,5bar		5bar		5,5bar		6bar		8bar		Sp. torque	
		0°	90°	0°	90°	0°	90°	0°	90°	0°	90°	90°	0°		0°	90°	0°	90°	0°	90°	0°	90°	0°	90°	0°	90°	0°	90°
00015	S1	5,0	3,0	7,0	4,7	8,0	6,3	10,0	8,0	10,7	8,7	5,3	3,3	S4	7,6	5,8	9,7	6,4	11,3	8,1	13,0	9,8	14,7	11,4	20,6	17,0	8,5	5,3
	S2	4,0	1,9	6,0	3,6	7,7	5,3	9,3	6,9	10,0	7,6	6,4	4,0	S5	7,0	4,9	9,0	5,4	10,7	7,0	12,3	8,7	14,0	10,0	20,6	17,0	9,6	5,9
	S3			5,3	2,5	7,0	4,2	8,7	5,8	9,4	6,6	7,4	4,6	S6			8,4	4,3	10,0	6,0	11,7	7,6	13,3	9,3	20,6	16,0	10,6	6,6
	S4			6,0	3,0	8,0	5,0	8,7	5,5	8,5	5,3	8,5	5,3	S7					9,4	4,9	11,0	6,6	13,0	8,2	19,3	14,9	11,7	7,3
	S5					7,3	3,7	8,1	4,4	9,6	5,9	9,6	5,9	S8							10,4	6,0	12,0	7,2	18,7	13,8	12,8	7,9
00030	2/3	9,1	6,2	12,0	9,2	15,0	12,1	17,9	15,0	19,1	16,2	8,4	6,0	4	15,7	11,1	17,5	12,9	20,4	15,8	23,4	18,7	26,3	21,7	36,9	31,7	13,5	9,0
	3	8,0	4,5	10,9	7,5	13,9	10,4	16,8	13,3	18	14,5	10,1	7,0	4/5	14,6	9,4	16,4	11,2	19,3	14,1	22,3	17,1	25,2	20,0	35,8	30,7	15,2	10,0
	3/4			9,8	5,8	12,8	8,7	15,7	11,6	16,9	12,8	11,8	7,8	5			15,3	9,5	18,2	12,4	21,1	15,4	24,1	18,3	35,8	30,7	16,9	11,1
	4					11,6	7,0	14,6	10,0	15,7	11,1	13,5	9,0	5/6					17,1	10,8	20,0	13,7	23,1	16,3	34,7	28,3	18,6	12,0
	4/5					13,5	8,3	14,6	9,4	15,2	10,0	6									18,9	12,0	21,9	14,9	33,6	26,7	20,2	13,3
00060	2/3	18,0	11,8	23,8	17,6	29,7	23,4	35,5	29,9	37,8	31,6	17,3	11,1	4	31,2	21,2	34,7	24,7	40,5	30,5	46,3	36,8	52,1	42,1	73,2	61,9	27,7	17,7
	3	15,8	8,3	21,6	14,1	27,5	19,9	33,3	25,8	35,6	28,1	20,8	13,3	4/5	29,0	17,7	32,5	21,2	38,3	27,0	44,1	32,8	49,9	38,6	71,0	58,5	34,6	22,1
	3/4			19,4	10,7	25,2	16,5	31,1	22,3	33,4	24,6	24,2	15,5	5			30,2	17,7	36,1	23,6	41,9	29,4	47,7	35,2	71,0	58,5	34,6	22,1
	4					23,0	13,0	28,8	18,8	31,2	21,2	27,7	17,7	5/6					33,8	20,1	39,7	25,9	45,5	31,7	68,7	55,0	38,1	24,3
	4/5					26,2	15,4	29,0	17,7	31,2	19,9	31,2	19,9	6							37,5	22,4	43,3	28,3	66,5	51,5	41,5	26,5
00100	2/3	27,4	16,9	36,6	26,0	45,7	35,2	64,9	44,3	58,5	48,0	28,9	18,3	4	47,5	30,7	53,0	36,2	62,2	45,3	71,3	54,5	80,5	63,6	113	94,5	52,0	33,0
	3	23,8	11,1	32,9	20,3	42,1	29,4	51,2	38,6	54,9	42,2	34,7	22,0	4/5	43,9	24,9	49,4	30,4	58,5	39,5	67,7	48,7	76,8	57,8	110	88,7	57,8	36,7
	3/4			29,2	14,5	38,4	23,6	47,5	32,8	51,2	36,4	40,4	25,7	5			45,7	24,6	54,8	33,8	64,0	42,9	73,1	52,1	110	88,7	57,8	36,7
	4					34,7	17,9	43,9	27,0	47,5	30,7	46,2	29,3	5/6					51,2	28,0	60,3	37,1	69,5	46,3	106	82,9	63,5	40,3
	4/5					40,2	21,2	43,9	24,9	52,0	33,0	52,0	33,0	6							56,7	31,4	65,8	40,5	102	77,1	69,3	44,0
00150	2/3	41,1	27,1	54,4	40,4	67,7	53,7	81,0	67,0	86,3	72,3	39,4	25,3	4	71,1	48,7	79,1	56,6	92,4	69,9	106	83,2	119	96,5	167	142	70,9	45,6
	3	36,1	19,2	49,4	32,5	62,7	45,8	76,0	59,1	81,3	64,4	47,3	30,4	4/5	66,0	40,8	74,0	48,8	87,3	62,1	101	75,3	114	88,6	167	142	70,9	45,6
	3/4			44,3	24,6	57,6	37,9	70,9	51,2	76,2	56,5	55,1	35,5	5			69,0	40,9	82,3	54,2	95,6	67,5	109	80,8	162	134	78,8	50,7
	4					65,8	43,3	71,1	48,7	63,0	40,5	63,0	40,5	5/6					77,2	46,3	90,5	59,6	104	72,9	157	126	86,7	55,7
	4/5					60,8	35,6	66,1	40,8	70,9	45,6	70,9	45,6	6							85,4	51,7	99,0	65,0	152	118	94,5	60,8
00220	2/3	66,5	41,9	87,9	63,4	109	84,9	131	106	140	115	65,5	41,0	4	115	75,7	128	88,6	149	110	171	132	192	153	270	226	118	73,8
	3	58,3	28,8	79,7	50,3	101	71,8	123	93,3	131	102	78,6	49,2	4/5	107	62,6	120	75,5	141	97,0	163	118	184	140	270	226	118	73,8
	3/4			71,5	37,2	93,0	59,0	115	80,2	123	88,8	91,7	57,4	5			111	62,0	133	83,9	154	105	176	127	262	213	131	82,0
	4					84,8	45,6	106	67,1	115	75,7	105	65,6	5/6					125	71,0	146	92,3	168	114	254	200	144	90,2
	4/5					98,1	54,0	107	62,6	118	73,8	118	73,8	6							138	79,0	159	101	245	187	157	98,4
00300	2/3	86,0	56,1	114	83,8	141	111	169	139	180	150	82,4	52,5	4	149	101	165	117	193	145	221	173	248	201	349	295	148	94,5
	3	75,5	39,6	103	67,3	131	95,0	159	123	170	134	98,9	63,0	4/5	138	84,3	155	101	182	129	210	156	238	184	349	295	148	94,5
	3/4			93,0	50,8	120	78,5	148	106	159	117	115	73,5	5			144	84	172	112	200	140	227	168	338	278	165	105
	4					110	62,0	138	89,7	149	101	132	84,0	5/6					161	96,0	189	123	217	151	318	262	181	116
	4/5					127	73,3	138	84,3	148	94,5	148	94,5	6							179	107	206	135	317	245	198	126
00450	2/3	135	88,6	179	132	222	176	265	219	283	236	129	82,4	4	233	159	260	185	303	229	347	272	390	316	547	464	232	148
	3	119	63,0	162	106	206	150	249	193	266	211	155	99	4/5	217	133	243	159	287	203	330	246	374	290	547	464	232	148
	3/4			146	80,0	189	124	233	167	250	185	180	115	5			227	134	270	177	314	221	357	264	531	438	258	165
	4					173	98,0	216	142	233	159	206	132	5/6					254	151	297	195	341	238	515	412	283	181
	4/5					200	116	217	133	232	148	232	148	6							281	169	324	213	498	386	309	198
00600	2/3	171	118	228	174	285	231	342	288	364	310	166	112	4	297	211	331	245	388	302	444	358	501	415	817	699	366	180
	3	149	84,0	206	141	262	198	319	255	342	277	199	135	4/5	275	178	309	212	365	268	422	325	479	382	706	609	299	202
	3/4			183	108	240	165	297	221	319	244	233	157	5			286	178	343	235	400	292	456	349	683	575	332	224



EDITION 2010
Dimensions
DR/SC00010U-10000U

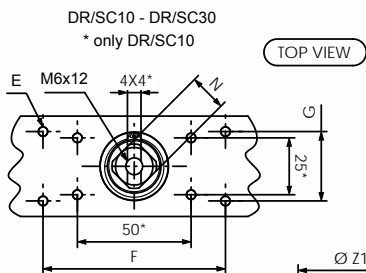

FRONT VIEW

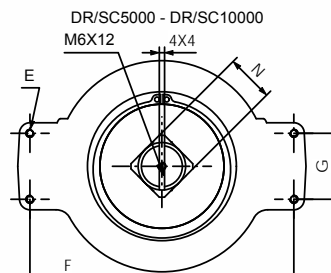
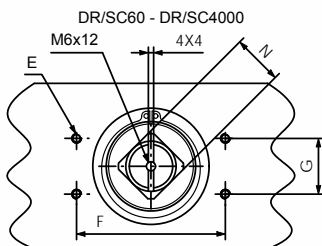

SIDE VIEW

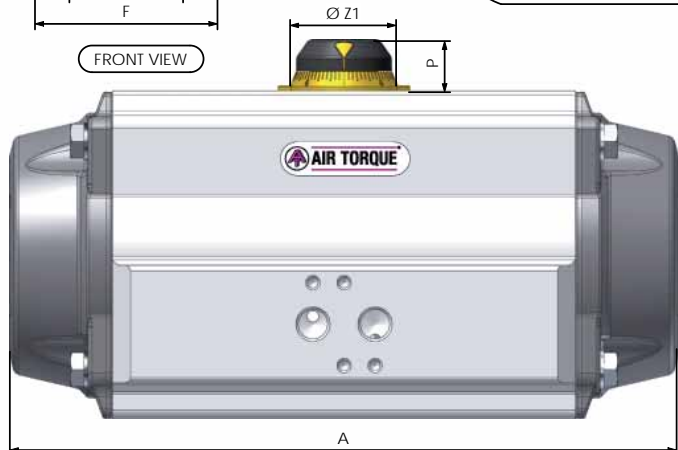

AIR CONNECTION VDI/DE 3845

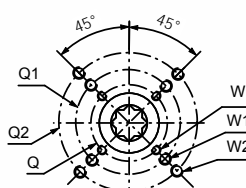
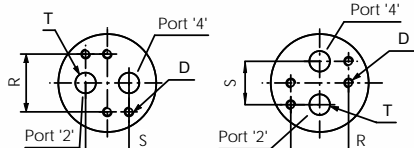

BOTTOM VIEW ISO 5211

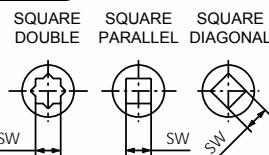

Type	00010		00015		00030		00060		00100		00150		00220		00300		00450		00600		00900		01200		02000		03000		04000		05000		10000																																																																																																																																																																																																																																																																																																																																																																												
	DR/SC	DR/SC	DR/SC	DR/SC	DR/SC	DR/SC	DR/SC	DR/SC	DR/SC	DR/SC	DR/SC	DR/SC	DR/SC	DR/SC	DR/SC	DR/SC	DR/SC	DR/SC	DR/SC	DR/SC	DR/SC	DR/SC	DR/SC	DR/SC	DR/SC	DR/SC	DR/SC	DR/SC	DR/SC	DR/SC	DR/SC	DR/SC																																																																																																																																																																																																																																																																																																																																																																													
DR Nm*	15	20	35	70	110	160	258	332	522	681	919	1276	2144	3112	4308	5405	10007	5	8	13	27	44	61	99	126	198	269	379	510	865	1309	1688	2207	4067	F04	F04	F05-F7	F05-F7	F05-F7	F07-10	F07-10	F07-10	F10-12	F10-12	(F12)F14	(F12)F14	(F14)F16	(F14)F16	F16(F25)	F16-25	F16-25-30	11 x 12	11 x 12	14 x 16	14 x 18	17 x 19	17 x 24	22 x 30	22 x 34	27 x 39	27 x 40	36 x 39	36 x 40	46 x 63	46 x 63	46 x 51	46 x 51	55 x 60	75 x 80	1/8"	1/8"	1/8"	1/8"	1/8"	1/4"	1/4"	1/4"	1/4"	1/4"	1/4"	1/4"	3/8"	1/2"	1/2"	1/2"	1/2"	1/2"	118	136	153.5	203.5	241	259	304	333	394.5	422.5	474	528	605	710	812	876	950	66	69	85	102	115	127	145	157	177	196	220.5	245	298.5	330	383	410	518	62	72	84.5	93	106	118.5	136	146.5	166	181	200	221.5	262	330	371	418	528	M5x8	M5x8	M5x8	M5x8	M5x8	M5x8	M5x8	M5x8	M5x8	M5x8	M5x8	M5x8	M6x10	M6x10	M6x10	M6x10	M6x10	M5x8	M5x8	M5x8	M5x8	M5x8	M5x8	M5x8	M5x8	M5x8	M5x8	M5x8	M5x8	M5x8	M5x8	M5x8	M5x8	M6x10	80	80	80	80	80	80	80	80	80	80	130	130	130	130	130	130	200	30	30	30	30	30	30	30	30	30	30	30	30	30	30	30	30	50	11	11	11	17	17	17	27	27	27	27	36	36	36	36	36	36	36	15	20	20	20	20	20	30	30	30	30	50	50	50	50	50	50	80	42	42	50	50	50	70	70	70	102	102	140	140	165	165	165	165	165	-	-	-	70	70	102	102	102	125	125	-	-	-	-	-	-	254	254	-	-	-	-	-	-	-	-	-	-	-	-	-	-	-	-	-	298	32	32	32	32	32	32	32	32	32	32	32	32	45	45	45	45	45	24	24	24	24	24	24	24	24	24	24	24	24	40	40	40	40	40	M5	M5	M6	M6	M6	M8	M8	M8	M10	M10	M16	M16	M20	M20	M20	M20	M20	-	-	M8	M8	M8	M10	M10	M10	M12	M12	-	-	-	-	-	-	M16	M16	-	-	-	-	-	-	-	-	-	-	-	-	-	-	-	-	-	M20	42	42	42	42	42	42	58	58	67.5	67.5	80	80	115	115	115	115	115

*Torque at 6 bar supply pressure, SC -> minimum spring torque (Fail safe action)

Time OPEN 1)	0.15	0.2	0.2	0.25	0.25	0.3	0.3	0.35	0.4	0.5	0.5	0.6	0.7	0.8	0.9	1.1	1.2	1.4	1.5	1.7	2	2.2	2.7	3.2	3.5	4	4	4.5	5	6	6	7.5	8	10																																		
Time CLOSE 1)	0.2	0.25	0.25	0.3	0.3	0.35	0.4	0.5	0.5	0.6	0.7	0.8	0.9	1.1	1.2	1.4	1.5	1.8	1.8	2.1	2.4	2.8	3.5	4	4.1	4.6	4.5	5	6	7	7	8.5	9	11																																		
Vol. OPEN 2)	0.06	0.09	0.16	0.31	0.51	0.71	1.19	1.54	2.41	3.14	4.26	5.94	10	14.5	20	25	49	0.1	0.15	0.26	0.49	0.78	1.11	1.8	2.34	3.78	4.92	6.89	9.46	15.2	21.38	33	40	84	0.75	0.9	1.0	1.1	1.6	1.7	2.7	3.1	3.7	4.3	5.2	6.1	8.0	9.3	9.8	12	14	17	18	22	24	33	34	42	53	67	74	93	123	155	127	169	170	238

1) Sec. 2) L 3) kg

Note:

(A) the above indicated moving time of the actuator is obtained under the following test conditions:

Für Typ DR/SC10 - DR/SC600: (1) room temperature, (2) actuator stroke 90°, (3) solenoid valve with Ø 4 mm and flow capacity Qn 400L/min., (4) inside pipe Ø 8 mm, (5) medium clean air, (6) air supply pressure 5.5 bar (79.75 Psi), (7) actuator without external resistance load.

Für Typ DR/SC900 - DR/SC10000: (1) room temperature, (2) actuator stroke 90°, (3) solenoid valve with Ø 11 mm and flow capacity Qn 6000L/min., (4) inside pipe Ø 11 mm, (5) medium clean air, (6) air supply pressure 5.5 bar (79.75 Psi), (7) actuator without external resistance load.

Caution: It has to be expected, that for field applications, when one or more of the above parameters are different, the moving time will be different.

Air Torque GmbH

Im Katzentach 16-18 · DE - 76275 Ettlingen
Tel.: +49 (0)7243 59 34-0 · Fax : +49 (0)7243 59 34-34
info@airtorque.de · www.airtorque.de

Modifications reserved. Date 11.2011.
No guarantee for accuracy.
Older data sheets are invalid.

TDG4
0403e



EDITION 2010
 Dimensions
 DR/SC00010U-10000U



AIR TORQUE
 PNEUMATISCHE STELLANTRIEBE

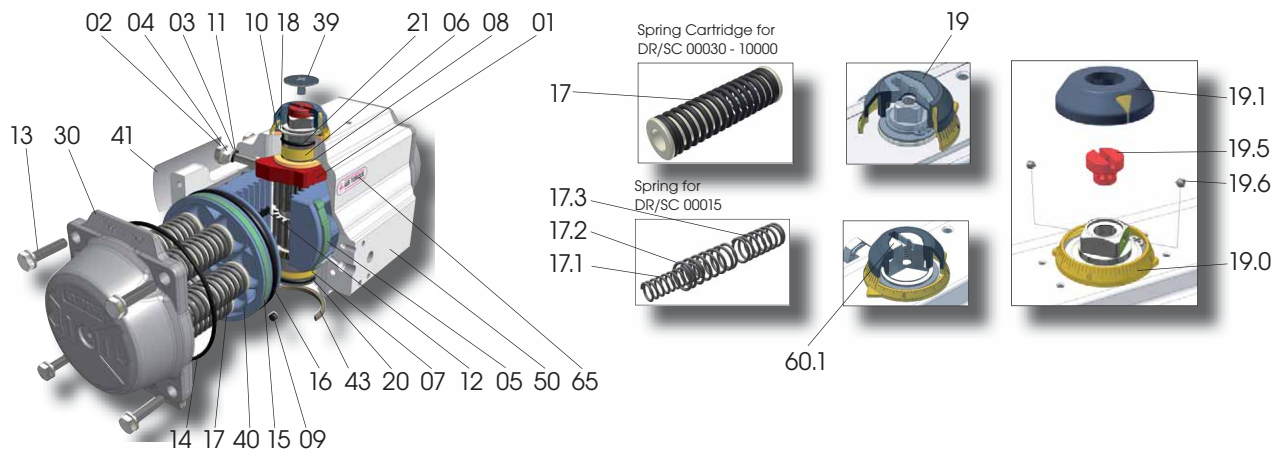

Pos.	Quantity / Note	Description	Material
01	1	Octi-Cam (Stop arrangement)	Stainless Steel (for DR/SC00015U - DR/SC00150U) Carbon Steel / Nodular Cast Iron, zinc coated
02	2	Stop Cap Screw	Stainless Steel
03	2	Washer	Stainless Steel
04	2	Nut (Stop screw)	Stainless Steel
05 ○	2 4 for DR/SC 10000U	Bearing (Piston top)	hochwertiger Kunststoff
06 ○	1	Bearing (Pinion top)	high-grade plastic
07 ○	1	Bearing (Pinion bottom)	high-grade plastic
08 ○	2	Thrust bearing	high-grade plastic
09 ○ □	2	Plug	Silicone
09.1 ○ □	2 for DR/SC 05000U-10000U	O-Ring plug	M-NBR
10	1	Thrust Washer	Stainless Steel
11 ○ □	2	O-Ring (Stop screw)	M-NBR
12	2	Piston Guide	high-grade plastic
13	8 for DR/SC 00015U-02000U 12 for DR/SC 03000U-04000U 16 for DR/SC 05000U-10000U	Cap Screw	Stainless Steel
13.1	16 for DR/SC 10000U	Washer (Cap screw end cap)	Stainless Steel
14 ○ □	2	O-Ring (End cap)	M-NBR
15 ○	2	Bearing (Piston head)	high-grade plastic
16 ○ □	2	O-Ring (Piston)	M-NBR
17	max.12 for DR/SC 00030U-10000U	Spring Cartridge	SiCr Spring Steel
17.1	max. 2 for DR/SC 00015U	Spring	
17.2		Spring	
17.3		Spring	
18	1	Spring Clip	SiCr Spring Steel, ENP
19	1 for DR/SC 00015U-00030U	Position Indicator	high-grade plastic / Stainless Steel
19.0	1	Graduated Ring	high-grade plastic
19.1	1 for DR/SC 00015U-00030U	Position Indicator	high-grade plastic
19.5	1 for DR/SC 00015U-00030U	Top Adaptor	Extruded Aluminium alloy, anodized
19.6	2 for DR/SC 00015U-00030U	Hex. Socket Screw (Top adaptor)	Stainless Steel
20 ○ □	1	O-Ring (Pinion bottom)	M-NBR
21 ○ □	1	O-Ring (Pinion top)	M-NBR
30	2	End Cap	Pressure Die Cast Aluminium alloy, coated Cast Aluminium alloy, coated (DR/SC10000)
39	1	Cap Screw (Indicator)	high-grade plastic
40	2	Piston	Pressure Die Cast Aluminium alloy, coated Cast Aluminium alloy, coated (DR/SC10000)
41	1	Label	Polyester Aluminium
43	1	Spigot (on request*)	Extruded Aluminium alloy, anodized
50	1	Body	Extruded Aluminium alloy, coated Cast Aluminium alloy, coated (DR/SC 05000+10000)
60	1	Drive Shaft	Extruded Aluminium alloy, anodized (DR/SC10000) Carbon Steel, ENP
60.1	1 not for all types	Integral Drive Shaft	Stainless Steel, ENP
65	1	Plastic Insert	high-grade plastic

○ enclosed in spare part kit □ enclosed in O-Ring kit *on request



Dimensions in mm

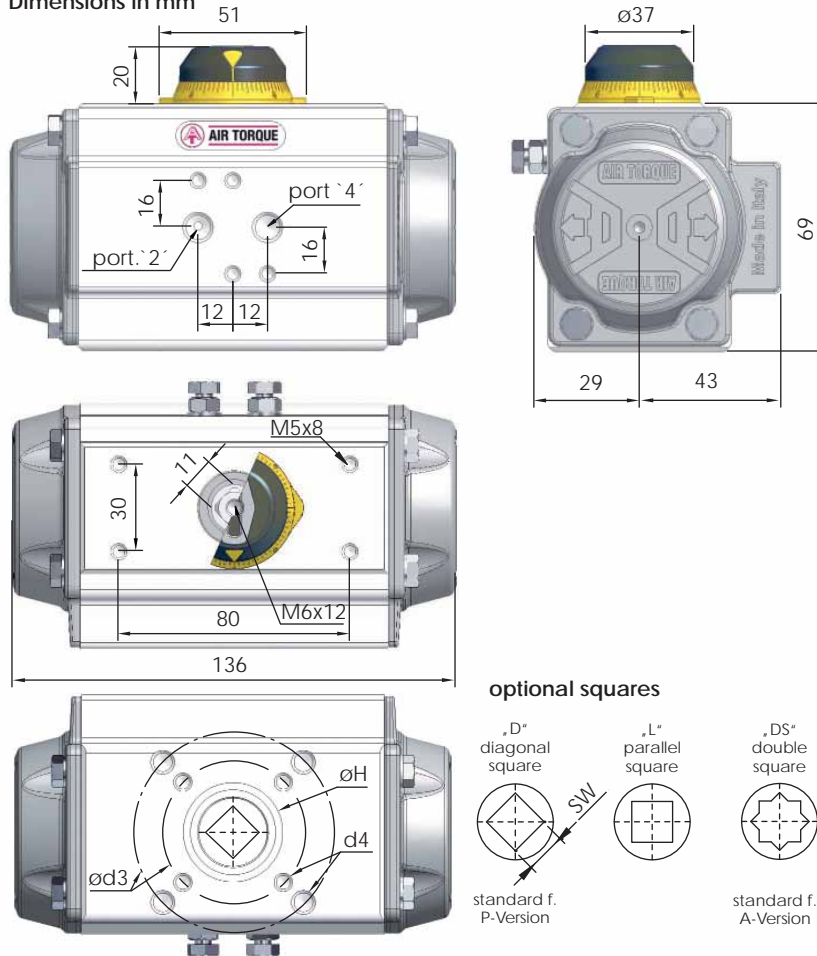

ISO 5211 - available flanges

ISO 5211	Standard		optional	
	F04		F03 + F05	
Ø d2	30	25	-	
d3	42	36	50	
Ø d4	M5 x 8	M5 x 8	M6 x 9	
Ø H	30	25		
SW x l min.	D	9 x 11 - 11 x 12		
	DS	11 x 12		
h min.	0,5	0,5	0,5	
h1	1,5	1,5	-	

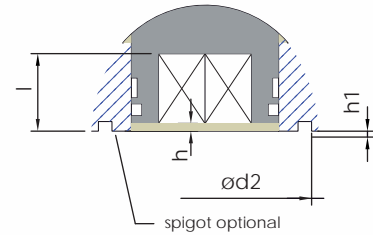

Connection / Attachment

Pressure connection port 2 and 4	G1/8"
Ancillaries attachment	AA0

Rotation and Stroke adjustment

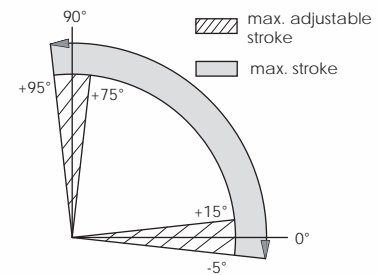

optional squares

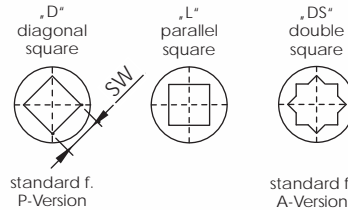

Pressure	Output torque for double acting and spring return in Nm												Spring torque	approx. weight in kg										
	2,5 bar		3 bar		3,5 bar		4 bar		4,2 bar		4,5 bar				5 bar		5,5 bar		6 bar		7 bar		8 bar	
	0°	90°	0°	90°	0°	90°	0°	90°	0°	90°	0°	90°			0°	90°	0°	90°	0°	90°	0°	90°	0°	90°
DR	8,3	10	11,6	13,3	14	15	16,6	18,3	19,9	23,3	26,6	-	-	-	-	-	-	-	-	-	-	-	1,1	

Springset

Springset	5,0	3,0	7,0	4,7	8,0	6,3	10,0	8,0	9,4	8,3	11,7	9,6	13,3	11,3						5,3	3,3	1,12			
SC S1	5,0	3,0	7,0	4,7	8,0	6,3	10,0	8,0	9,4	8,3	11,7	9,6	13,3	11,3						5,3	3,3	1,12			
SC S2	4,0	1,9	6,0	3,6	7,7	5,3	9,3	6,9	9,0	7,4	11,0	8,6	12,7	10,2	14,3	11,9				6,4	4	1,14			
SC S3			5,3	2,5	7,0	4,2	8,7	5,8	8,2	6,6	10,3	7,5	12,0	9,2	13,7	10,8	15,3	12,5		7,4	4,6	1,16			
SC S4					6,3	3,0	8,0	5,0	7,6	5,8	9,7	6,4	11,3	8,1	13,0	9,8	14,7	11,4	18,0	14,7	8,5	5,3	1,18		
SC S5							7,3	3,7	7,0	4,9	9,0	5,4	10,7	7,0	12,3	8,7	14,0	10,0	17,3	13,7	20,6	17,0	1,2		
SC S6											8,4	4,3	10,0	6,0	11,7	7,6	13,3	9,3	16,7	12,6	20,0	16,0	10,6	6,6	1,22
SC S7												9,4	4,9	11,0	6,6	13,0	8,2	16,0	11,6	19,3	14,9	11,7	7,3	1,24	
SC S8															10,4	6,0	12,0	7,2	15,3	10,5	18,7	13,8	12,8	7,9	1,26

Pressure	Rotation max. (STD) (C)	Screw stroke adjustment	Chamber Ø (mm)	Air volume (l)		Moving time (sec.) (A)	
				OPEN	CLOSE	OPEN	CLOSE
8 bar	0° - 90°	for 1° 1/6 rotation	50	0,09	0,15	D 0,20 S 0,25	D 0,25 S 0,30

Operating temperature (°C) (B)		
ST (Standard)	HT (High temperature)	LLT (Extreme low temperature)
- 40 to + 80	- 15 to + 150	- 55 to + 80

(A) the above indicated moving time of the actuator is obtained under the following test conditions: (1) room temperature, (2) actuator stroke 90°, (3) solenoid valve with Ø 4 mm and flow capacity Qn 400 L/min., (4) inside pipe Ø 8 mm, (5) medium clean air, (6) air supply pressure 5,5 bar (79,75 Psi), (7) actuator without external resistance load. **Caution:** It has to be expected, e.g. for field applications, when one or more of the above parameters are different, the moving time will be different.

(B) Every temperature range option requires proper components and lubricant. Please contact Air Torque GmbH.

Operating Medium:

The operating medium must be free of dust and oil. The maximum particle size must not exceed 30µ. (ISO 8573 Part1, Class5). In order to prevent water condensation and/or solidification (ice when actuator works below 0°C), the operating medium must have a dew point equal to -20°C or at least 10°C below the ambient temperature (ISO 8573 Part1, Class3)



Dimensions in mm

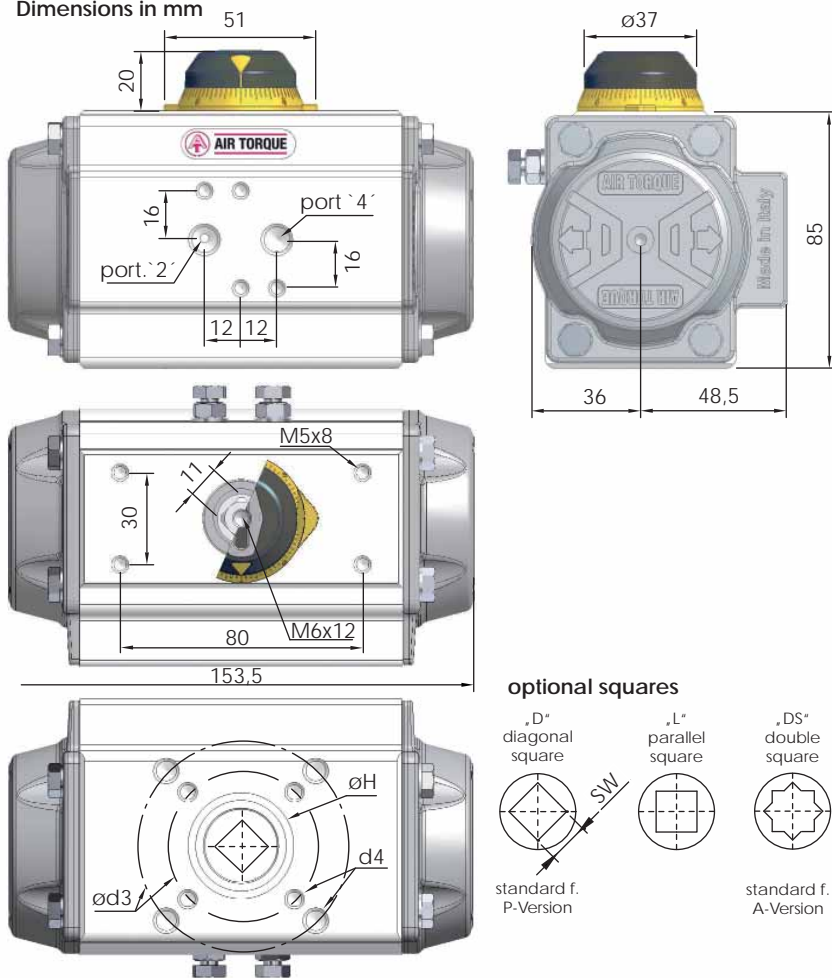

ISO 5211 - available flanges

ISO 5211	Standard		optional			
	F05 + F07	F03* + F05	F04 + F07	F05		
$\varnothing d2$	35	25	30	35		
$\varnothing d3$	50	70	42	70	50	
d4	M6x9	M8x12	M5x8	M6x9	M5x8	M8x12
$\varnothing H$	35	25	30	35		
SW x I	D		9 x 11 - 14 x 16			
min. DS	14 x 16		11 x 18 - 14 x 16			
h min.	0,5	0,5	0,5	0,5	0,5	0,5
h1	2	1,5	2	2	2	2

*before selecting the flange connection please consider the indications of standard n° 5211 on page 0911 of our manual for op. and maintenance

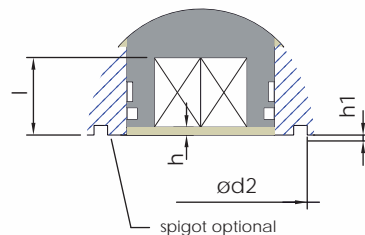

Connection / Attachment

Pressure connection Port 2 and 4	G1/8"
Ancillaries attachment	AA 1

Rotation and stroke adjustment

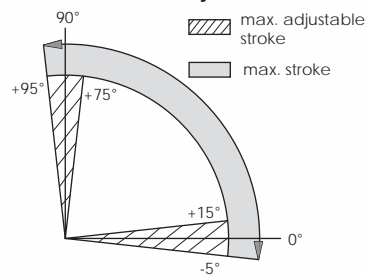

optional squares

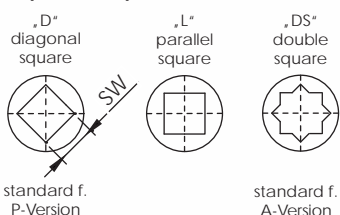

Pressure	Output torque for double acting and spring return in Nm												Spring torque		approx. weight in kg										
	2,5 bar		3 bar		3,5 bar		4 bar		4,2 bar		4,5 bar		5 bar			5,5 bar		6 bar		7 bar		8 bar		90°	0°
	0°	90°	0°	90°	0°	90°	0°	90°	0°	90°	0°	90°	0°	90°		0°	90°	0°	90°	0°	90°				
DR	14,7	17,6	20,5	23,5	24,6	26,4	29,3	32	35,2	41	46,9	-	-	1,61											

SC 2/3	9,1	6,2	12,0	9,2	15,0	12,1	17,9	15	19,1	16,2	20,8	17,9	23,8	20,9									8,4	5,5	1,71						
SC 3	8,0	4,5	10,9	7,5	13,9	10,4	16,8	13,3	18	14,5	19,7	16,3	22,7	19,2	25,6	22,1										10,1	6,7	1,73			
SC 3/4			9,8	5,8	12,8	8,7	15,7	11,6	16,9	12,8	18,6	14,6	21,5	17,5	24,5	20,4	27,4	23,4										11,8	7,8	1,75	
SC 4					11,6	7	14,6	10,0	15,7	11,1	17,5	12,9	20,4	15,8	23,4	18,7	26,3	21,7	32,2	27,5									13,5	8,9	1,77
SC 4/5							13,5	8,3	15	9,4	16,4	11,2	19,3	14,1	22,3	17,1	25,2	20	31,1	25,9	36,9	31,7							15,2	10	1,79
SC 5											15,3	9,5	18,2	12,4	21,1	15,4	24,1	18,3	29,9	24,2	35,8	30							16,9	11,1	1,81
SC 5/6													17,1	10,8	20	13,7	23	16,6	28,8	22,5	34,7	28,3							18,6	12,2	1,83
SC 6															18,9	12	21,9	14,9	27,7	20,8	33,6	26,7							20,2	13,3	1,85

Pressure max.	Rotation (STD) (C)	Screw stroke adjustment	Chamber \varnothing (mm)	Air volume (L)		Moving time (sec.) (A)	
				OPEN	CLOSE	OPEN	CLOSE
8 bar	0° - 90°	for 1° 1/6 rotation	63	0,16	0,26	D 0,25 S 0,30	D 0,30 S 0,35

Operating temperature (°C) (B)		
ST (Standard)	HT (High temperature)	LLT (Extreme low temperature)
- 40 to + 80	- 15 to + 150	- 55 to + 80

(A) the above indicated moving time of the actuator is obtained under the following test conditions: (1) room temperature, (2) actuator stroke 90°, (3) solenoid valve with $\varnothing 4$ mm and flow capacity Q_n 400 L/min., (4) inside pipe $\varnothing 8$ mm, (5) medium clean air, (6) air supply pressure 5,5 bar (79,75 Psi), (7) actuator without external resistance load. **Caution:** It has to be expected, e.g. for field applications, when one or more of the above parameters are different, the moving time will be different.

Operating Medium:

The operating medium must be free of dust and oil. The maximum particle size must not exceed 30 μ . (ISO 8573 Part1, Class5). In order to prevent water condensation and/or solidification (ice when actuator works below 0°C), the operating medium must have a dew point equal to -20°C or at least 10°C below the ambient temperature (ISO 8573 Part1, Class3)

(B) Every temperature range option requires proper components and lubricant. Please contact Air Torque GmbH.



Dimensions in mm

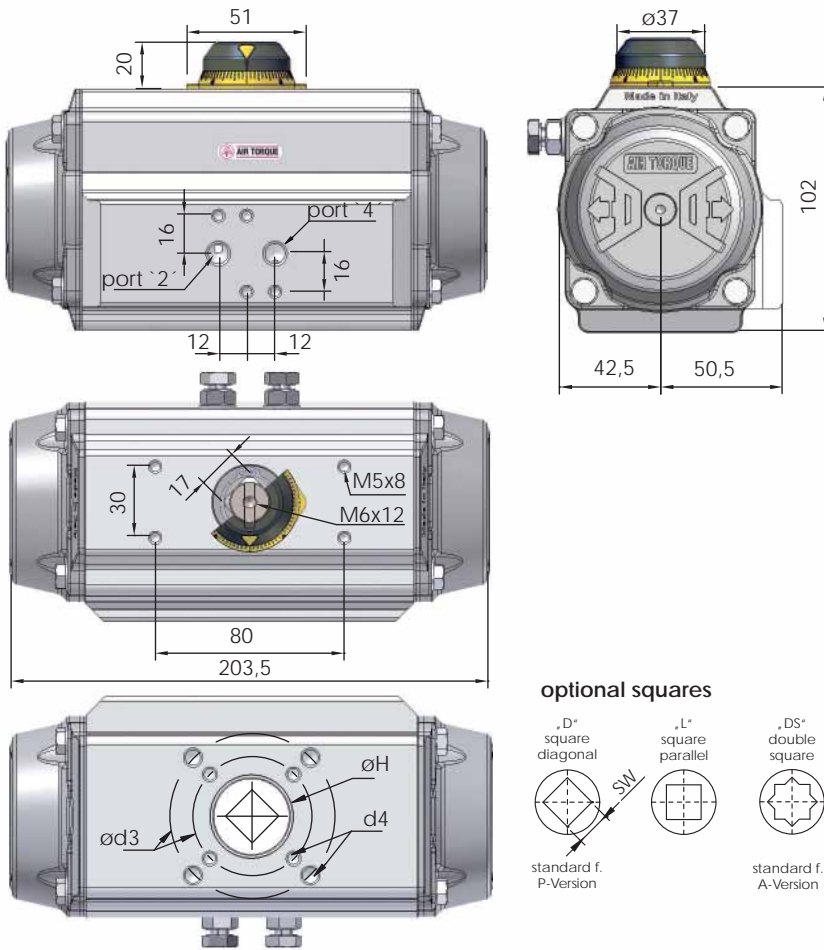

ISO 5211 - available flanges

ISO 5211	Standard		optional	
	F05 + F07	F05	F04* + F07	
Ø d2	35	-	35	-
Ø d3	50	70	50	42 70
d4	M6x9	M8x12	M6x9	M5x8 M8x12
Ø H	35		35	-
SW x l min.	D	-		
	DS	11 x 18 - 14 x 16		
h min.	0,5	0,5	0,5	0,5
h1	2	-	2	-

*before selecting the flange connection please consider the indications of standard n° 5211 on page 0911 of our manual for op. and maintenance

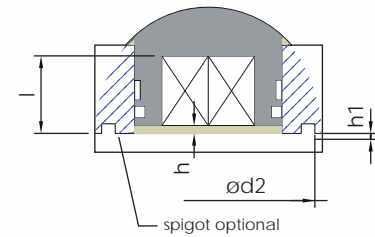

Connection / Attachment

Pressure connection port 2 and 4	G1/8"
Ancillaries attachment	AA 1

Rotation and stroke adjustment

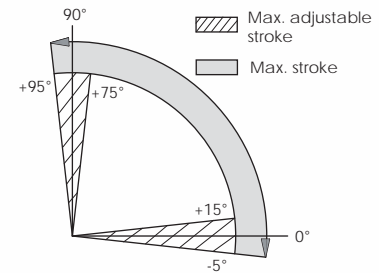

optional squares

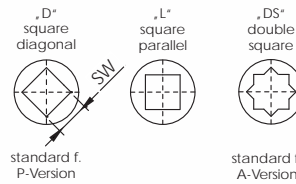

Pressure	Output torque for double acting and spring return in Nm														Spring torque	approx. weight in kg								
	2,5 bar		3 bar		3,5 bar		4 bar		4,2 bar		4,5 bar		5 bar				5,5 bar		6 bar		7 bar		8 bar	
	0°	90°	0°	90°	0°	90°	0°	90°	0°	90°	0°	90°	0°	90°			0°	90°	0°	90°	0°	90°	0°	90°
DR	29,1	34,9	40,7	46,5	48,9	52,4	58,2	64	69,8	81,4	93,1	-	-	-	-	-	-	-	-	-	-	-	2,68	

SC 2/3	18 11,8	23,8 17,6	29,7 23,4	35,5 29,2	37,8 31,6	41,3 35,0	47,1 40,9																17,3 11,1	2,83	
SC 3	15,8 8,3	21,6 14,1	27,5 19,9	33,3 25,8	35,6 28,1	39,1 31,6	44,9 37,4	50,7 43,2																20,8 13,3	2,86
SC 3/4		19,4 10,7	25,2 16,5	31,1 22,3	33,4 24,6	36,9 28,1	42,7 33,9	48,5 39,8	54,3 45,6															24,2 15,5	2,89
SC 4			23 13	28,8 18,8	31,2 21,2	34,7 24,7	40,5 30,5	46,3 36,3	52,1 42,1	63,7 53,7														27,7 17,7	2,92
SC 4/5				26,6 15,4	29 17,7	32,5 21,2	38,3 27	44,1 32,8	49,9 38,6	61,5 50,3	73,2 61,9													31,2 19,9	2,95
SC 5						30,2 17,7	36,1 23,6	41,9 29,4	47,7 35,2	59,3 46,8	71 58,5													34,6 22,1	2,98
SC 5/6							33,8 20,1	39,7 25,9	45,5 31,7	57,1 43,4	68,7 55													38,1 24,3	3,01
SC 6								37,5 22,4	43,3 28,3	54,9 39,9	66,5 51,5													41,5 26,5	3,04

Pressure max.	Rotation (STD) (C)	Screw stroke adjustment	Chamber Ø (mm)	Air volume (L)		Moving time (sec.) (A)	
				OPEN	CLOSE	OPEN	CLOSE
8 bar	0° - 90°	for 1° 1/6 rotation	75	0,31	0,49	D 0,30 S 0,40	D 0,35 S 0,50

Operating temperature (°C) (B)		
ST (Standard)	HT (High temperature)	LLT (Extreme low temperature)
- 40 to + 80	- 15 to + 150	- 55 to + 80

(A) the above indicated moving time of the actuator is obtained under the following test conditions: (1) room temperature, (2) actuator stroke 90°, (3) solenoid valve with Ø 4 mm and flow capacity Qn 400 L/min., (4) inside pipe Ø 8 mm, (5) medium clean air, (6) air supply pressure 5,5 bar (79,75 Psi), (7) actuator without external resistance load. **Caution:** It has to be expected, e.g. for field applications, when one or more of the above parameters are different, the moving time will be different.

Operating Medium:

The operating medium must be free of dust and oil. The maximum particle size must not exceed 30µ. (ISO 8573 Part1, Class5). In order to prevent water condensation and/or solidification (ice when actuator works below 0°C), the operating medium must have a dew point equal to -20°C or at least 10°C below the ambient temperature (ISO 8573 Part1, Class3)

(B) Every temperature range option requires proper components and lubricant. Please contact Air Torque GmbH.



Dimensions in mm

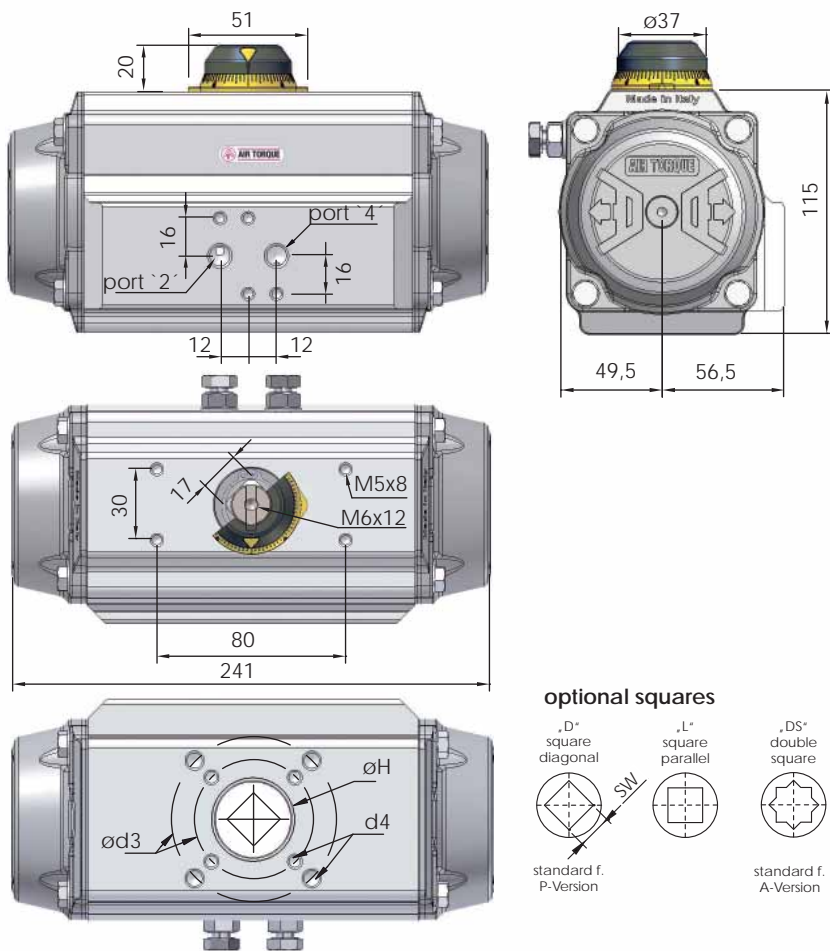

ISO 5211 - available flanges

	Standard		optional
ISO 5211	F05* + F07		F07
Ø d2	40	-	55
Ø d3	50	70	70
d4	M6x9	M8x12	M8 x 12
Ø H	40		55
SW x l min.	D	-	11x19 - 14x18 - 17x19
	DS	17 x 19	17 x 19
h min.	1,5	1,5	1,5
h1	1,5	-	2

*before selecting the flange connection please consider the indications of standard n° 5211 on page 0911 of our manual for op. and maintenance

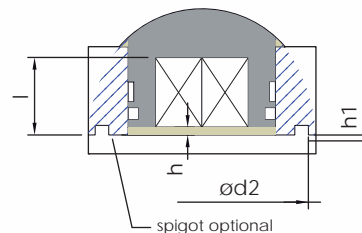

Connection / Attachment

Pressure connection Port 2 and 4	G1/8"
Ancillaries attachment	AA 1

Rotation and stroke adjustment

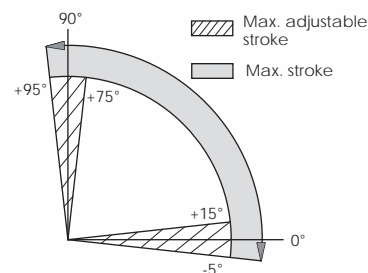

Pressure	Output torque for double acting and spring return in Nm												Spring torque	approx. weight in kg										
	2,5 bar		3 bar		3,5 bar		4 bar		4,2 bar		4,5 bar				5 bar		5,5 bar		6 bar		7 bar		8 bar	
	0°	90°	0°	90°	0°	90°	0°	90°	0°	90°	0°	90°			0°	90°	0°	90°	0°	90°	0°	90°	0°	90°
DR	45,8	54,9	64,1	73,2	76,9	82,4	91,5	101	110	128	146	-	-	-	-	-	-	-	-	-	-	-	3,82	

SC 2/3	27,4 16,9	36,6 26	45,7 35,2	54,9 44,3	58,5 48	64 53,5	73,2 62,6																28,9 18,3	4,07	
SC 3	23,8 11,1	32,9 20,3	42,1 29,4	51,2 38,6	54,9 42,2	60,4 47,7	69,5 56,9	78,7 66																34,7 22	4,12
SC 3/4		29,2 14,5	38,4 23,6	47,5 32,8	51,2 36,4	56,7 41,9	65,8 51,1	75 60,2	84,2 69,4															40,4 25,7	4,17
SC 4			34,7 17,9	43,9 27	47,5 30,7	53 36,2	62,2 45,3	71,3 54,5	80,5 63,6	98,8 81,9														46,2 29,3	4,22
SC 4/5				40,2 21,2	43,9 24,9	49,4 30,4	58,5 39,5	67,7 48,7	76,8 57,8	95,1 76,1	113 94,5													52 33	4,27
SC 5						45,7 24,6	54,8 33,8	64 42,9	73,1 52,1	91,5 70,4	110 88,7													57,8 36,7	4,32
SC 5/6							51,2 28	60,3 37,1	69,5 46,3	87,8 64,6	106 82,9													63,5 40,3	4,37
SC 6									56,7 31,4	65,8 40,5	84,1 58,8	102 77,1												69,3 44	4,42

Pressure max.	Rotation (STD) (C)	Screw stroke adjustment	Chamber (Ø mm)	Air volume (L)		Moving time (sec.) (A)	
				OPEN	CLOSE	OPEN	CLOSE
8 bar	0° - 90°	for 1° 1/5 rotation	88	0,51	0,78	D 0,40 S 0,50	D 0,50 S 0,60

Operating temperature (°C) (B)		
ST (Standard)	HT (High temperature)	LLT (Extreme low temperature)
- 40 to + 80	- 15 to + 150	- 55 to + 80

(A) the above indicated moving time of the actuator is obtained under the following test conditions: (1) room temperature, (2) actuator stroke 90°, (3) solenoid valve with Ø 4 mm and flow capacity Qn 400 L/min., (4) inside pipe Ø 8 mm, (5) medium clean air, (6) air supply pressure 5,5 bar (79,75 Psi), (7) actuator without external resistance load. **Caution:** It has to be expected, e.g. for field applications, when one or more of the above parameters are different, the moving time will be different.

Operating Medium:

The operating medium must be free of dust and oil. The maximum particle size must not exceed 30µ. (ISO 8573 Part1, Class5). In order to prevent water condensation and/or solidification (ice when actuator works below 0°C), the operating medium must have a dew point equal to -20°C or at least 10°C below the ambient temperature (ISO 8573 Part1, Class3)

(B) Every temperature range option requires proper components and lubricant. Please contact Air Torque GmbH.



Dimensions in mm

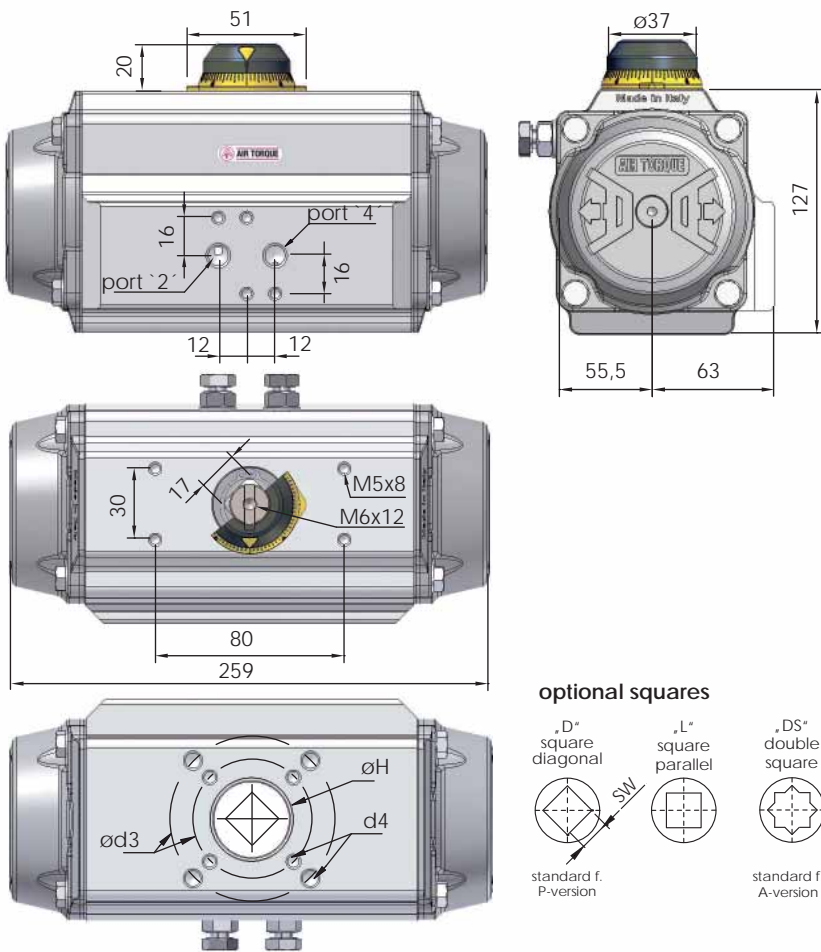

ISO 5211 - available flanges

ISO 5211	Standard		optional	
	F07 + F10	F05* + F07	F07	F07
Ø d2	55	-	-	55
d3	70	102	50	70
Ø d4	M8x12	M10x15	M6x9	M8x12
Ø H	55	-	-	55
SW x l min.	D	-	14 x 18 - 17 x 19	
	DS	17 x 24	17 x 24 - 22 x 24	
h min.	1,5	1,5	1,5	1,5
h1	2	-	-	2

*before selecting the flange connection please consider the indications of standard n° 5211 on page 0911 of our manual for op. and maintenance

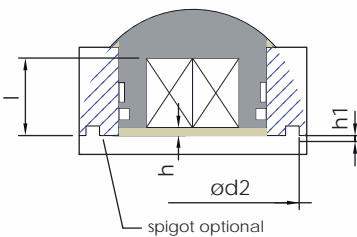

Connection / Attachment

Pressure connection port 2 and 4	G1/4"
Ancillaries attachment	AA 1

Rotation and stroke adjustment

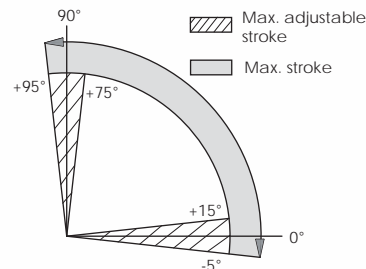

optional squares

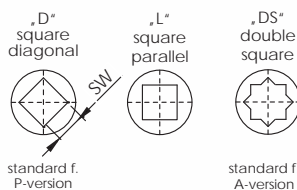

Pressure	Output torque for double acting and spring return in Nm											Spring torque	approx. weight	
	2,5 bar	3 bar	3,5 bar	4 bar	4,2 bar	4,5 bar	5 bar	5,5 bar	6 bar	7 bar	8 bar			90°
DR	66,5	79,8	93,1	106	112	120	133	146	160	186	213			5,15

SC 2/3	41,1 27,1	54,4 40,4	67,7 53,7	81 67	86,3 72,3	94,3 80,3	108 93,6					39,4 25,3	5,50
SC 3	36,1 19,2	49,4 32,5	62,7 45,8	76 59,1	81,3 64,4	89,3 72,4	103 85,7	116 99				47,3 30,4	5,57
SC 3/4		44,3 24,6	57,6 37,9	70,9 51,2	76,2 56,5	84,2 64,5	97,5 77,8	111 91,1	124 104			55,1 35,5	5,64
SC 4			52,5 30	65,8 43,3	71,1 48,7	79,1 56,6	92,4 69,9	106 83,2	119 96,5	146 123		63 40,5	5,71
SC 4/5				60,8 35,5	66 40,8	74 48,8	87,3 62,1	101 75,3	114 88,6	141 115	167 142	70,9 45,6	5,78
SC 5						69 40,9	82,3 54,2	95,6 67,5	109 80,8	135 107	162 134	78,8 50,7	5,85
SC 5/6							77,2 46,3	90,5 59,6	104 72,9	130 99,5	157 126	86,7 55,7	5,92
SC 6								85,4 51,7	98,7 65	125 91,6	152 118	94,5 60,8	5,99

Pressure max.	Rotation (STD) (C)	Screw stroke adjustment	Chamber (Ø mm)	Air volume (l)		Moving time (sec.) (A)	
				OPEN	CLOSE	OPEN	CLOSE
8 bar	0° - 90°	for 1° / 1/5 rotation	100	0,71	1,11	D 0,50 S 0,70	D 0,60 S 0,90

Operating temperature (°C) (B)		
ST (Standard)	HT (High temperature)	LLT (Extreme low temperature)
- 40 to + 80	- 15 to + 150	- 55 to + 80

(A) the above indicated moving time of the actuator is obtained under the following test conditions: (1) room temperature, (2) actuator stroke 90°, (3) solenoid valve with Ø 4 mm and flow capacity Qn 400 L/min., (4) inside pipe Ø 8 mm, (5) medium clean air, (6) air supply pressure 5,5 bar (79,75 Psi), (7) actuator without external resistance load. **Caution:** It has to be expected, e.g. for field applications, when one or more of the above parameters are different, the moving time will be different.

Operating Medium:

The operating medium must be free of dust and oil. The maximum particle size must not exceed 30µ. (ISO 8573 Part1, Class5). In order to prevent water condensation and/or solidification (ice when actuator works below 0°C), the operating medium must have a dew point equal to -20°C or at least 10°C below the ambient temperature (ISO 8573 Part1, Class3)

(B) Every temperature range option requires proper components and lubricant. Please contact Air Torque GmbH.



Dimensions in mm

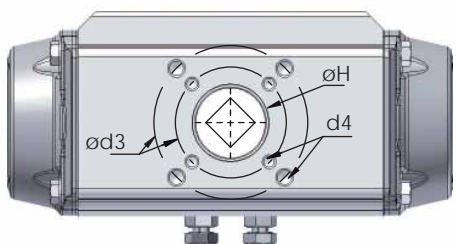
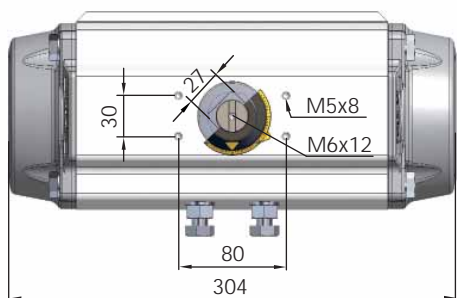
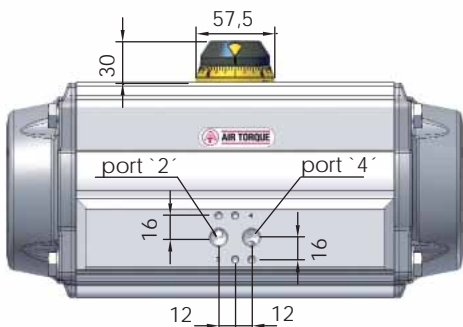

optional squares

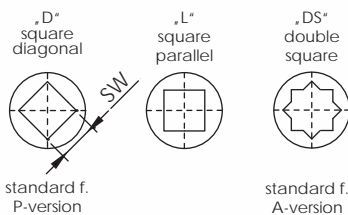

ISO 5211 - available flanges

ISO 5211	Standard		optional
	F07* + F10	F10	F10
Ø d2	55	-	70
Ø d3	70	102	102
d4	M8x12	M10x15	M10 x 15
Ø H	55		70
SW x l min.	D	-	14 x 18 - 22 x 24
	DS	22 x 30	17 x 24 - 22 x 30
h min.	1,5	1,5	1,5
h1	2	-	2

*before selecting the flange connection please consider the indications of standard n° 5211 on page 0911 of our manual for op. and maintenance

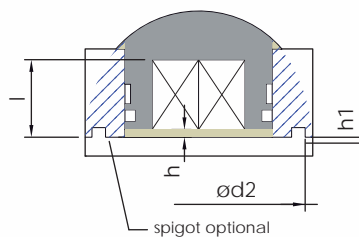

Connection / Attachment

Pressure connection port 2 and 4	G1/4"
Ancillaries attachment	AA 2

Rotation and stroke adjustment

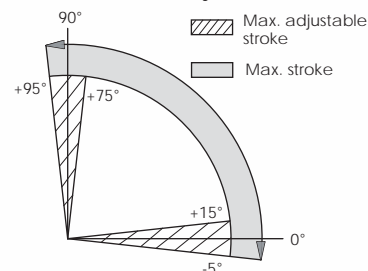

Pressure	Output torque for double acting and spring return in Nm												Spring torque 90°	approx. weight in kg										
	2,5 bar		3 bar		3,5 bar		4 bar		4,2 bar		4,5 bar				5 bar		5,5 bar		6 bar		7 bar		8 bar	
	0°	90°	0°	90°	0°	90°	0°	90°	0°	90°	0°	90°			0°	90°	0°	90°	0°	90°	0°	90°	0°	90°
DR	107	129	150	172	181	193	215	236	258	301	344	-	8,07											

SC 2/3	66,5	41,9	87,9	63,4	109	84,9	131	106	140	115	152	128	174	149									65,5	41	8,62			
SC 3	58,3	28,8	79,7	50,3	101	71,8	123	93,3	131	102	144	115	166	136	187	158									78,6	49,2	8,73	
SC 3/4			71,5	37,2	93	58,7	115	80,2	123	88,8	136	102	158	123	179	145	200	166								91,7	57,4	8,84
SC 4					84,8	45,6	106	67,1	115	75,7	128	88,6	149	110	171	132	192	153	235,3	196						105	65,6	8,95
SC 4/5							98,1	54	107	62,6	120	75,5	141	97	163	118	184	140	227,1	183	270	226				118	73,8	9,06
SC 5											111	62,4	133	83,9	154	105	176	127	218,9	170	262	213				131	82	9,17
SC 5/6													125	70,8	146	92,3	168	114	210,7	157	254	200				144	90,2	9,28
SC 6															138	79,2	159	101	202,5	144	245	187				157	98,4	9,39

Pressure max.	Rotation (STD) (C)	Screw stroke adjustment	Chamber (Ø mm)	Air volume (l)		Moving time (sec.) (A)	
				OPEN	CLOSE	OPEN	CLOSE
8 bar	0° - 90°	for 1° 1/5 rotation	115	1,19	1,8	D 0,70 S 0,90	D 0,80 S 1,10

Operating temperature (°C) (B)		
ST (Standard)	HT (High temperature)	LLT (Extreme low temperature)
- 40 to + 80	- 15 to + 150	- 55 to + 80

(A) The above indicated moving time of the actuator is obtained under the following test conditions: (1) room temperature, (2) actuator stroke 90°, (3) solenoid valve with Ø 4 mm and flow capacity Qn 400 L/min., (4) inside pipe Ø 8 mm, (5) medium clean air, (6) air supply pressure 5,5 bar (79,75 Psi), (7) actuator without external resistance load. **Caution:** It has to be expected, e.g. for field applications, when one or more of the above parameters are different, the moving time will be different.

(B) Every temperature range option requires proper components and lubricant. Please contact Air Torque GmbH.

Operating Medium:

The operating medium must be free of dust and oil. The maximum particle size must not exceed 30µ. (ISO 8573 Part1, Class5). In order to prevent water condensation and/or solidification (ice when actuator works below 0°C), the operating medium must have a dew point equal to -20°C or at least 10°C below the ambient temperature (ISO 8573 Part1, Class3)



Dimensions in mm

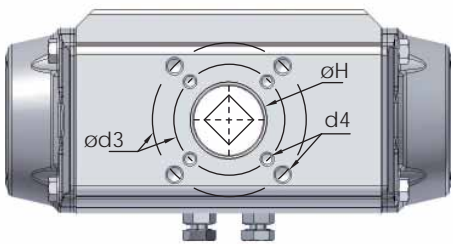
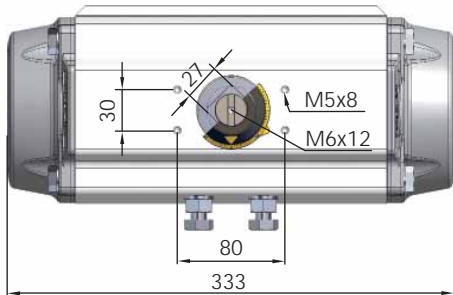
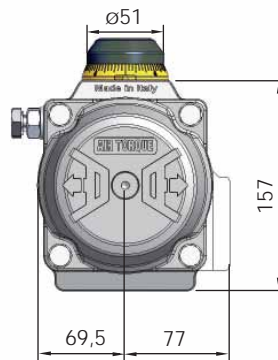
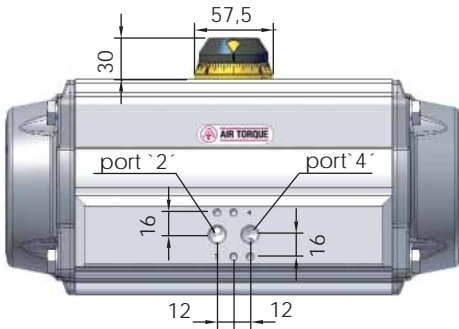

optional squares

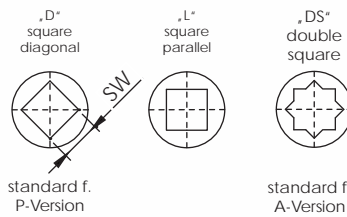

ISO 5211 - available flanges

ISO 5211	Standard		optional
	F07* + F10		F10
Ø d2	55	-	70
d3	70	102	102
Ø d4	M8x12	M10x15	M10 x 15
Ø H	55		70
SW x l min.	D	17 x 24 - 22 x 24	
	DS	22 x 34 - 27 x 27	
h min.	1,5	1,5	1,5
h1	2	-	1,5

*before selecting the flange connection please consider the indications of standard n° 5211 on page 0911 of our manual for op. and maintenance

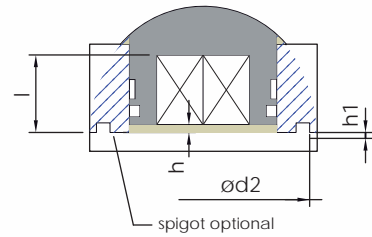

Connection / Attachment

Pressure connection port 2 and 4	G1/4"
Ancillaries attachment	AA 2

Rotation and stroke adjustment

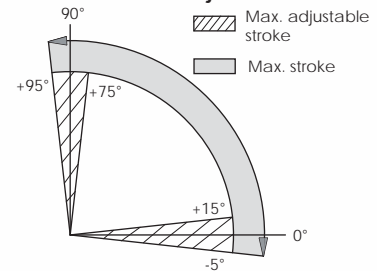

Pressure	Output torque for double acting and spring return in Nm												Spring torque 90°	approx. weight in kg										
	2,5 bar		3 bar		3,5 bar		4 bar		4,2 bar		4,5 bar				5 bar		5,5 bar		6 bar		7 bar		8 bar	
	0°	90°	0°	90°	0°	90°	0°	90°	0°	90°	0°	90°			0°	90°	0°	90°	0°	90°	0°	90°	0°	90°
DR	138	166	194	222	233	249	277	305	332	388	443	-	9,97											

SC 2/3	86	56,1	114	83,8	141	111	169	139	180	150	197	167	224	195									82,4	52,5	10,97	
SC 3	75,5	39,6	103	67,3	131	95	159	123	170	134	186	150	214	178	242	206								98,9	63	11,17
SC 3/4			92,7	50,8	120	78,5	148	106	159	117	176	134	203	162	231	189	259	217						115	73,5	11,37
SC 4					110	62	138	89,7	149	101	165	117	193	145	221	173	248	201	304	256				132	84	11,57
SC 4/5					127	73,3	138	84,3	155	101	182	129	210	156	238	184	293	239	349	295				148	94,5	11,77
SC 5									144	84,5	172	112	200	140	227	168	283	223	338	278				165	105	11,97
SC 5/6											161	95,7	189	123	217	151	272	206	328	262				181	116	12,17
SC 6													179	107	206	135	262	190	317	245				198	126	12,37

Pressure max.	Rotation (STD) (C)	Screw stroke adjustment	Chamber (Ø mm)	Air volume (L)		Moving time (sec.) (A)	
				OPEN	CLOSE	OPEN	CLOSE
8 bar	0° - 90°	for 1° 1/4 rotation	125	1,54	2,34	D 0,9	D 1,1 S 1,2

Operating temperature (°C) (B)		
ST (Standard)	HT (High temperature)	LLT (Extreme low temperature)
- 40 to + 80	- 15 to + 150	- 55 to + 80

(A) the above indicated moving time of the actuator is obtained under the following test conditions: (1) room temperature, (2) actuator stroke 90°, (3) solenoid valve with Ø 4 mm and flow capacity Qn 400 L/min., (4) inside pipe Ø 8 mm, (5) medium clean air, (6) air supply pressure 5,5 bar (79,75 Psi), (7) actuator without external resistance load. **Caution:** It has to be expected, e.g. for field applications, when one or more of the above parameters are different, the moving time will be different.

Operating Medium:

The operating medium must be free of dust and oil. The maximum particle size must not exceed 30µ. (ISO 8573 Part1, Class5). In order to prevent water condensation and/or solidification (ice when actuator works below 0°C), the operating medium must have a dew point equal to -20°C or at least 10°C below the ambient temperature (ISO 8573 Part1, Class3)

(B) Every temperature range option requires proper components and lubricant. Please contact Air Torque GmbH.



Dimensions in mm

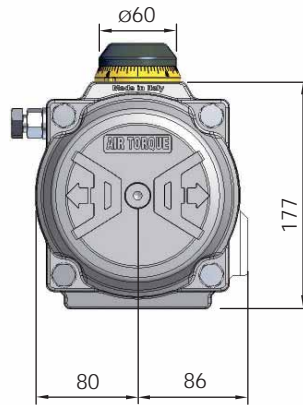
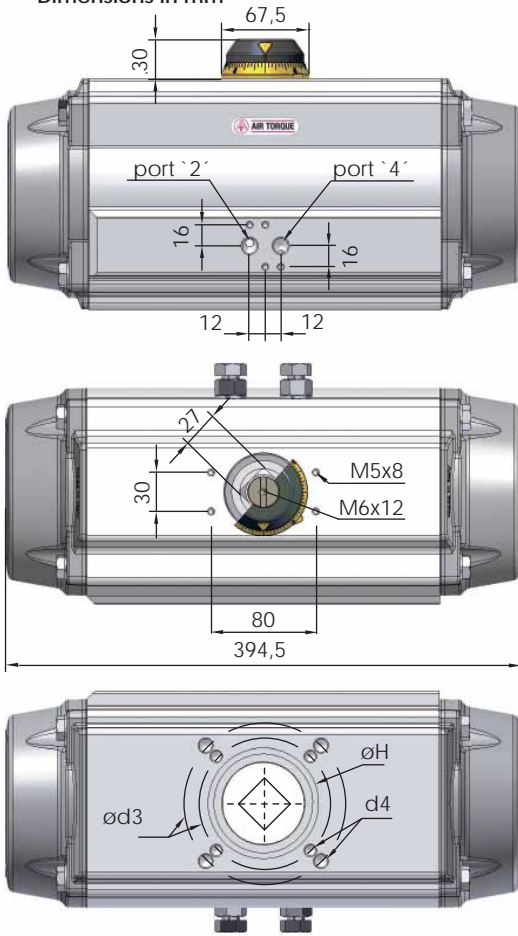

optional squares

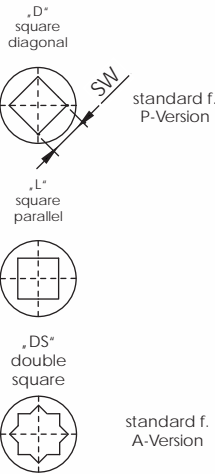

ISO 5211 - available flanges

ISO 5211	Standard		optional
	F10* + F12	F12	F12
Ø d2	70	-	85
d3	102	125	125
Ø d4	M10x15	M12x18	M12 x 18
Ø H	70	-	85
SW x l min.	D	-	22 x 34 - 27 x 29
	DS	27 x 39	27 x 39
h min.	1,5	1,5	1,5
h1	3	-	1,5

*before selecting the flange connection please consider the indications of standard n° 5211 on page 0911 of our manual for op. and maintenance

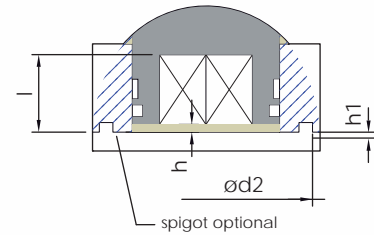

Connection / Attachment

Pressure connection port 2 and 4	G1/4"
Ancillaries attachment	AA 2

Rotation and stroke adjustment

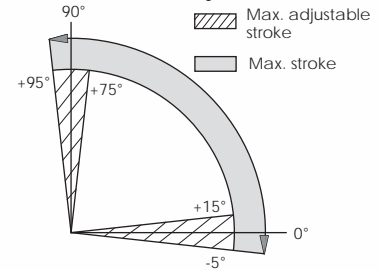

Pressure	Output torque for double acting and spring return in Nm												Spring torque	approx. weight in kg										
	2,5 bar		3 bar		3,5 bar		4 bar		4,2 bar		4,5 bar				5 bar		5,5 bar		6 bar		7 bar		8 bar	
	0°	90°	0°	90°	0°	90°	0°	90°	0°	90°	0°	90°			0°	90°	0°	90°	0°	90°	0°	90°	0°	90°
DR	217	261	304	348	365	391	435	478	522	609	696	-	-	-	-	-	-	-	-	-	-	-	14,2	

SC 2/3	135	88,6	179	132	222	176	265	219	283	236	309	262	352	306									129	82,4	15,4	
SC 3	119	62,8	162	106	206	150	249	193	266	211	293	237	336	280	379	324								155	99	15,6
SC 3/4			146	80,5	189	124	233	167	250	185	276	211	320	254	363	298	406	341						180	115	15,9
SC 4					173	98,2	216	142	233	159	260	185	303	229	347	272	390	316	477	403				206	132	16,1
SC 4/5							200	116	217	133	243	159	287	203	330	246	374	290	460	377	547	464		232	148	16,4
SC 5											227	134	270	177	314	221	357	264	444	351	531	438		258	165	16,6
SC 5/6													254	151	297	195	341	238	428	325	515	412		283	181	16,9
SC 6															281	169	324	213	411	299	498	386		309	198	17,1

Pressure max.	Rotation (STD) (C)	Screw stroke adjustment	Chamber (Ø mm)	Air volume (l)		Moving time (sec.) (A)	
				OPEN	CLOSE	OPEN	CLOSE
8 bar	0° - 90°	for 1° / 1/4 rotation	145	2,41	3,78	D 1,2	D 1,4
						S 1,5	S 1,8

Operating temperature (°C) (B)		
ST (Standard)	HT (High temperature)	LLT (Extreme low temperature)
- 40 to + 80	- 15 to + 150	- 55 to + 80

(A) the above indicated moving time of the actuator is obtained under the following test conditions: (1) room temperature, (2) actuator stroke 90°, (3) solenoid valve with Ø 4 mm and flow capacity Qn 400 l/min., (4) inside pipe Ø 8 mm, (5) medium clean air, (6) air supply pressure 5,5 bar (79,75 Psi), (7) actuator without external resistance load. **Caution:** It has to be expected, e.g. for field applications, when one or more of the above parameters are different, the moving time will be different.

Operating Medium:

The operating medium must be free of dust and oil. The maximum particle size must not exceed 30µ. (ISO 8573 Part1, Class5). In order to prevent water condensation and/or solidification (ice when actuator works below 0°C), the operating medium must have a dew point equal to -20°C or at least 10°C below the ambient temperature (ISO 8573 Part1, Class3)

(B) Every temperature range option requires proper components and lubricant. Please contact Air Torque GmbH.



Dimensions in mm

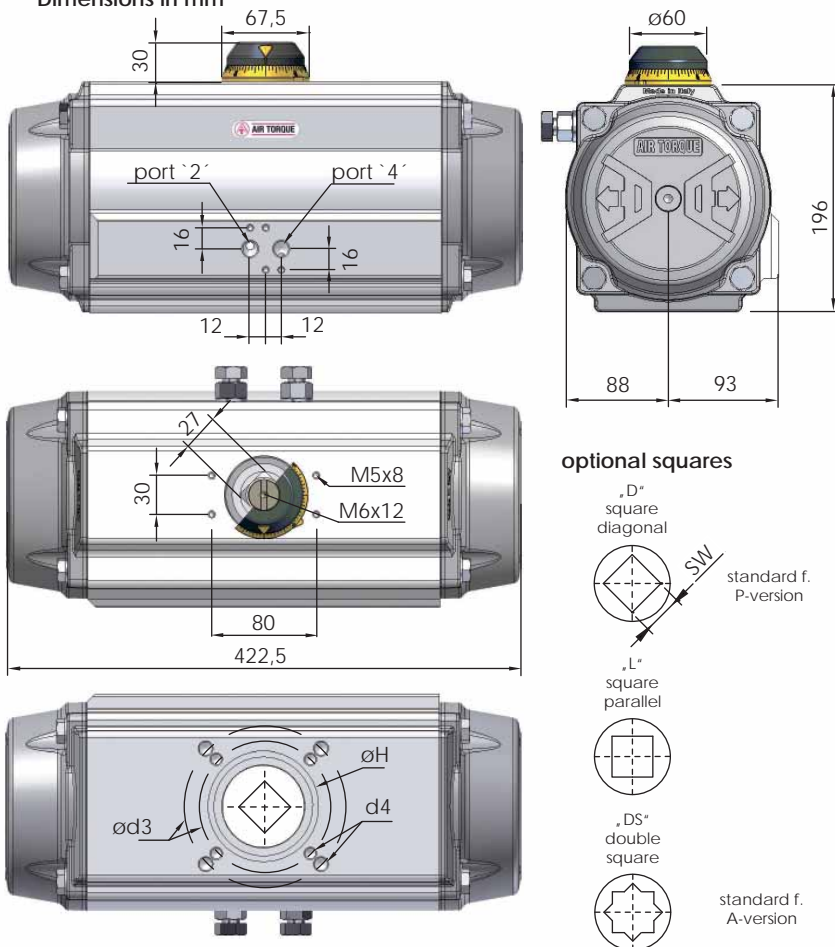

ISO 5211 - available flanges

ISO 5211	Standard		optional
	F10* + F12	F12	F12
Ø d2	70	-	85
d3	102	125	125
Ø d4	M10x15	M12x18	M12 x 18
Ø H	70		85
SW x l min.	D	-	22 x 40 - 27 x 29
	DS	27 x 40	27 x 40
h min.	1,5	1,5	1,5
h1	3	-	1,5

*before selecting the flange connection please consider the indications of standard n° 5211 on page 0911 of our manual for op. and maintenance

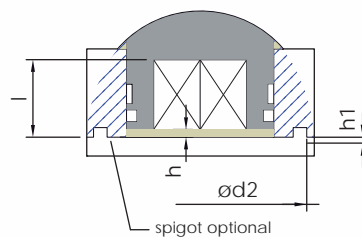

Connection / Attachment

Pressure connection Port 2 and 4	G1/4"
Ancillaries attachment	AA 2

Rotation and stroke adjustment

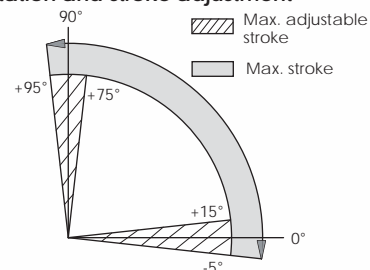

Pressure	Output torque for double acting and spring return in Nm												Spring torque	approx. weight in kg										
	2,5 bar		3 bar		3,5 bar		4 bar		4,2 bar		4,5 bar				5 bar		5,5 bar		6 bar		7 bar		8 bar	
	0°	90°	0°	90°	0°	90°	0°	90°	0°	90°	0°	90°			0°	90°	0°	90°	0°	90°	0°	90°	0°	90°
DR	284	340	397	454	477	511	567	624	681	794	908	-	17,8											

SC 2/3	171	118	228	174	285	231	342	288	364	310	398	344	455	401								166	112	19,3	
SC 3	149	84,3	206	141	262	198	319	255	342	277	376	311	433	368	489	425							199	135	19,6
SC 3/4			183	108	240	165	297	221	319	244	353	278	410	335	467	391	524	448					233	157	19,9
SC 4					218	131	274	188	297	211	331	245	388	302	444	358	501	415	615	528			266	180	20,2
SC 4/5					252	155	275	178	309	212	365	268	422	325	479	382	592	495	706	609			299	202	20,5
SC 5									286	178	343	235	400	292	456	349	570	462	683	575			332	224	20,8
SC 5/6											320	202	377	259	434	315	547	429	661	542			365	247	21,1
SC 6													355	225	411	282	525	396	638	509			399	269	21,4

Pressure max.	Rotation (STD) (C)	Screw stroke adjustment	Chamber Ø (mm)	Air volume (L)		Moving time (sec.) (A)	
				OPEN	CLOSE	OPEN	CLOSE
8 bar	0° - 90°	for 1° / 1/4 rotation	160	3,14	4,92	D 1,5 S 1,8	D 1,7 S 2,1

Operating Temperature (°C) (B)		
ST (Standard)	HT (High temperature)	LLT (Extreme low temperature)
- 40 to + 80	- 15 to + 150	- 55 to + 80

(A) the above indicated moving time of the actuator is obtained under the following test conditions: (1) room temperature, (2) actuator stroke 90°, (3) solenoid valve with Ø 4 mm and flow capacity Qn 400 L/min., (4) inside pipe Ø 8 mm, (5) medium clean air, (6) air supply pressure 5,5 bar (79,75 Psi), (7) actuator without external resistance load. **Caution:** It has to be expected, e.g. for field applications, when one or more of the above parameters are different, the moving time will be different.

Operating Medium:

The operating medium must be free of dust and oil. The maximum particle size must not exceed 30µ. (ISO 8573 Part1, Class5). In order to prevent water condensation and/or solidification (ice when actuator works below 0°C), the operating medium must have a dew point equal to -20°C or at least 10°C below the ambient temperature (ISO 8573 Part1, Class3)

(B) Every temperature range option requires proper components and lubricant. Please contact Air Torque GmbH.



Dimensions in mm

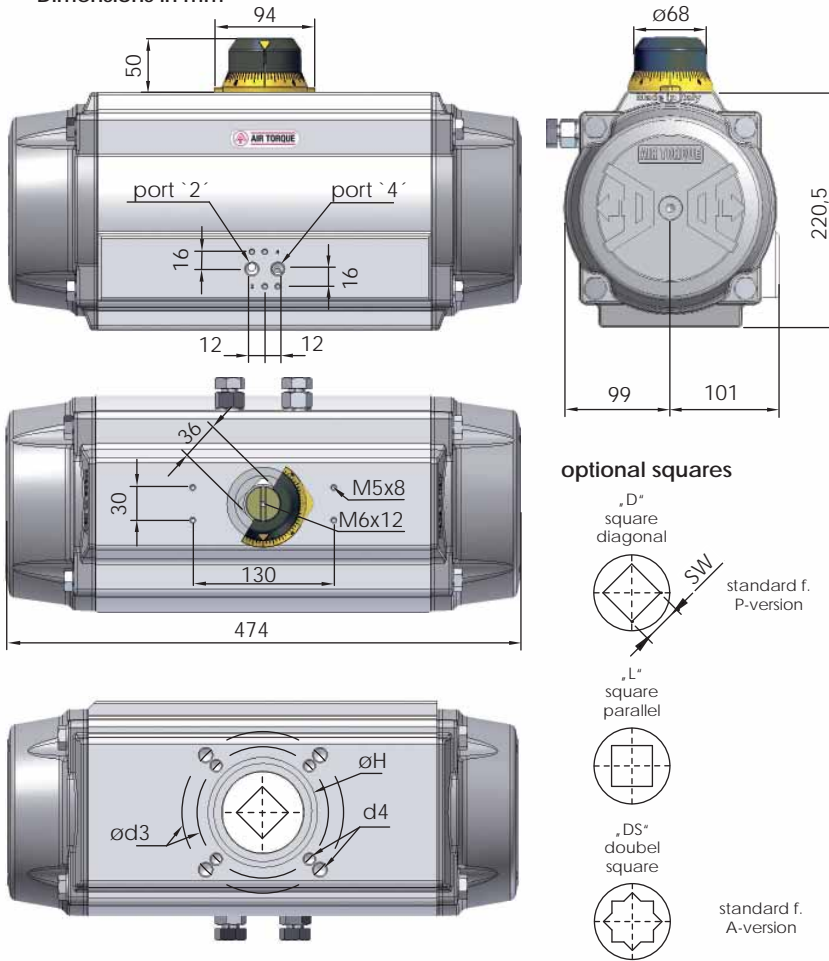

ISO 5211 - available flanges

	Standard	optional	
ISO 5211	F14	F10*+ F12*	
Ø d2	100	-	85
Ø d3	140	102	125
d4	M16 x 24	M10 x 15	M12 x 18
Ø H	100	70	
SW x l min.	D	22 x 39 - 36 x 39	
	DS	36 x 39	
h min.	2	2	2
h1	3	-	1,5

*before selecting the flange connection please consider the indications of standard n° 5211 on page 0911 of our manual for op. and maintenance

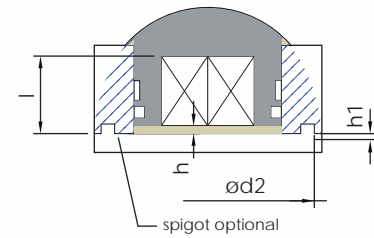

optional squares

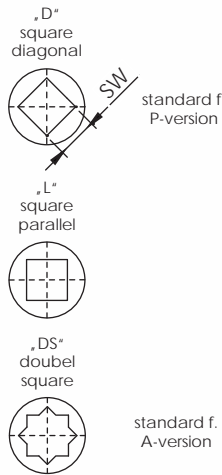

Connection / Attachment

Pressure connection port 2 and 4	G1/4"
Ancillaries attachment	AA 4

Rotation and stroke adjustment

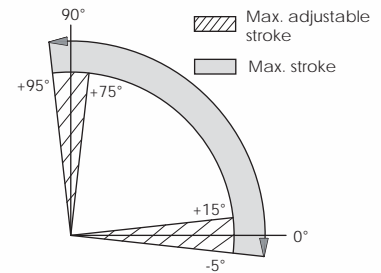

Pressure	Output torque for double acting and spring return in Nm												Spring torque	approx. weight in kg										
	2,5 bar		3 bar		3,5 bar		4 bar		4,2 bar		4,5 bar				5 bar		5,5 bar		6 bar		7 bar		8 bar	
	0°	90°	0°	90°	0°	90°	0°	90°	0°	90°	0°	90°			0°	90°	0°	90°	0°	90°	0°	90°	0°	90°
DR	383	459	536	613	643	689	766	842	919	1072	1225	-	24,3											

SC 2/3	225	146	301	223	378	299	455	376	485	406	531	452	608	529							237	158	27,8
SC 3	193	99	270	175	346	252	423	329	454	359	500	405	576	482	653	558					284	190	28,5
SC 3/4			238	128	315	205	391	281	422	312	468	358	544	434	621	511	698	587			332	221	29,2
SC 4					283	157	360	234	390	264	436	310	513	387	589	464	666	540	819	693	379	253	29,9
SC 4/5					328	186	359	217	405	263	481	340	558	416	634	493	788	646	941	799	426	285	30,6
SC 5									373	216	450	292	526	369	603	445	756	599	909	752	474	316	31,3
SC 5/6									418	245	495	321	571	398	672	551	877	704	1021	857	521	348	32
SC 6													463	274	540	351	693	504	846	657	568	379	32,7

Pressure max.	Rotation (STD) (C)	Screw stroke adjustment	Chamber (Ø mm)	Air volume (L)		Moving time (sec.) (A)	
				OPEN	CLOSE	OPEN	CLOSE
8 bar	0° - 90°	for 1° 1/4 rotation	180	4,26	6,89	D 2,0 S 2,4	D 2,2 S 2,8

Operating temperature (°C) (B)		
ST (Standard)	HT (High temperature)	LLT (Extreme low temperature)
- 40 to + 80	- 15 to + 150	- 55 to + 80

(A) the above indicated moving time of the actuator is obtained under the following test conditions: (1) room temperature, (2) actuator stroke 90°, (3) solenoid valve with Ø 4 mm and flow capacity Qn 6000 L/min., (4) inside pipe Ø 11 mm, (5) medium clean air, (6) air supply pressure 5,5 bar (79,75 Psi), (7) actuator without external resistance load. **Caution:** It has to be expected, e.g. for field applications, when one or more of the above parameters are different, the moving time will be different.

(B) Every temperature range option requires proper components and lubricant. Please contact Air Torque GmbH.

Operating Medium:

The operating medium must be free of dust and oil. The maximum particle size must not exceed 30µ. (ISO 8573 Part1, Class5). In order to prevent water condensation and/or solidification (ice when actuator works below 0°C), the operating medium must have a dew point equal to -20°C or at least 10°C below the ambient temperature (ISO 8573 Part1, Class3)



Dimensions in mm

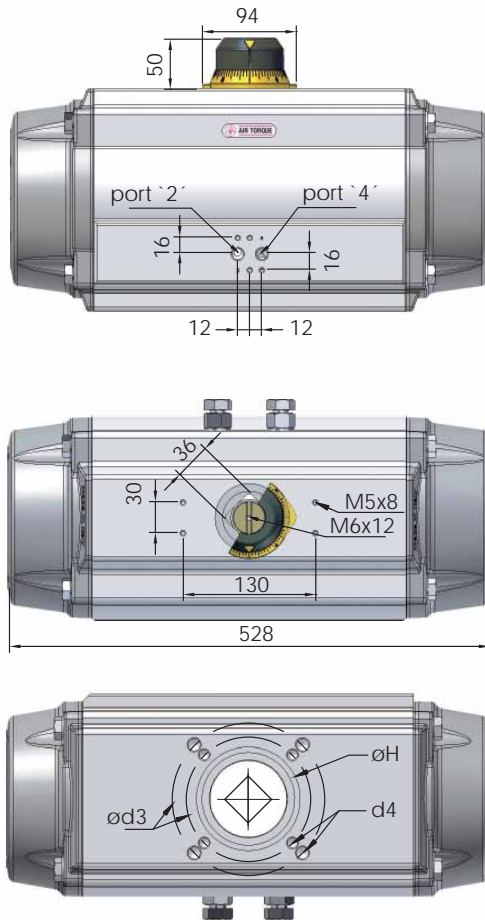

ISO 5211 - available flanges

ISO 5211	Standard		optional	
	F14	F10* + F12*		
Ø d2	100	-	85	
Ø d3	140	102	125	
d4	M16 x 24	M10 x 15	M12 x 18	
Ø H	100		85	
SW x l min.	D	-	22 x 40 - 36 x 40	
	DS	36 x 40	27 x 40 - 36 x 40	
h min.	2	2	2	
h1	3	-	1,5	

*before selecting the flange connection please consider the indications of standard n° 5211 on page 0911 of our manual for op. and maintenance

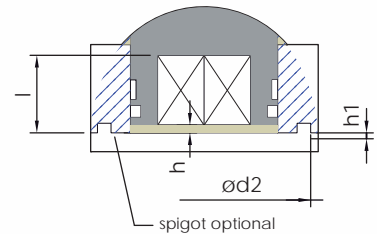

optional squares

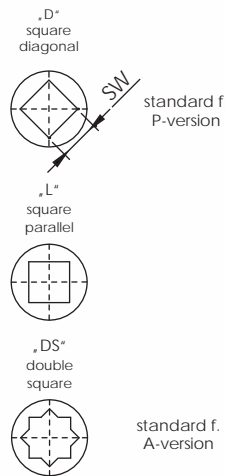

Connection / Attachment

Pressure connection port 2 and 4	G1/4"
Ancillaries attachment	AA 4

Rotation and stroke adjustment

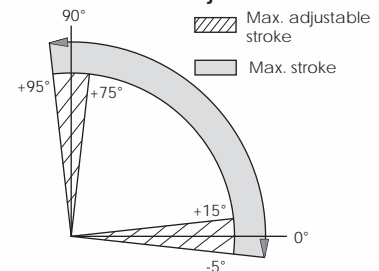

Pressure	Output torque for double acting and spring return in Nm												Spring torque	approx. weight in kg										
	2,5 bar		3 bar		3,5 bar		4 bar		4,2 bar		4,5 bar				5 bar		5,5 bar		6 bar		7 bar		8 bar	
	0°	90°	0°	90°	0°	90°	0°	90°	0°	90°	0°	90°			0°	90°	0°	90°	0°	90°	0°	90°	0°	90°
DR	532		638		745		851		893		957		1064		1170		1276		1489		1702	-	34,3	

SC 2/3	319	217	426	323	532	430	638	536	681	578	745	642	851	749								315	213	38,2			
SC 3	277	154	383	260	489	367	596	473	638	515	702	579	808	686	915	792							378	255	39		
SC 3/4			341	197	447	304	553	410	596	453	660	516	766	623	872	729	979	835					441	298	39,7		
SC 4					404	241	511	347	553	390	617	453	723	560	830	666	936	772	1149	985			504	340	40,5		
SC 4/5							468	284	511	327			575	390	681	497	787	603	894	709	1106	922	1319	1135	567	383	41,3
SC 5											532	327	638	434	745	540	851	646	1064	859	1277	1072	630	425	42		
SC 5/6													596	371	702	477	809	583	1021	796	1234	1009	693	468	42,8		
SC 6															660	414	766	520	979	733	1192	946	756	510	43,6		

Pressure max.	Rotation (STD) (C)	Screw stroke adjustment	Chamber Ø (mm)	Air volume (L)		Moving time (sec.) (A)	
				OPEN	CLOSE	OPEN	CLOSE
8 bar	0° - 90°	for 1° 1/4 rotation	200	5,94	9,46	D 2,7 S 3,5	D 3,2 S 4,0

Operating temperature (°C) (B)		
ST (Standard)	HT (High temperature)	LLT (Extreme low temperature)
- 40 to + 80	- 15 to + 150	- 55 to + 80

(A) the above indicated moving time of the actuator is obtained under the following test conditions: (1) room temperature, (2) actuator stroke 90°, (3) solenoid valve with Ø 4 mm and flow capacity Qn 6000 L/min., (4) inside pipe Ø 11 mm, (5) medium clean air, (6) air supply pressure 5,5 bar (79,75 Psi), (7) actuator without external resistance load. **Caution:** It has to be expected, e.g. for field applications, when one or more of the above parameters are different, the moving time will be different.

Operating Medium:

The operating medium must be free of dust and oil. The maximum particle size must not exceed 30µ. (ISO 8573 Part1, Class5). In order to prevent water condensation and/or solidification (ice when actuator works below 0°C), the operating medium must have a dew point equal to -20°C or at least 10°C below the ambient temperature (ISO 8573 Part1, Class3)

(B) Every temperature range option requires proper components and lubricant. Please contact Air Torque GmbH.



Dimensions in mm

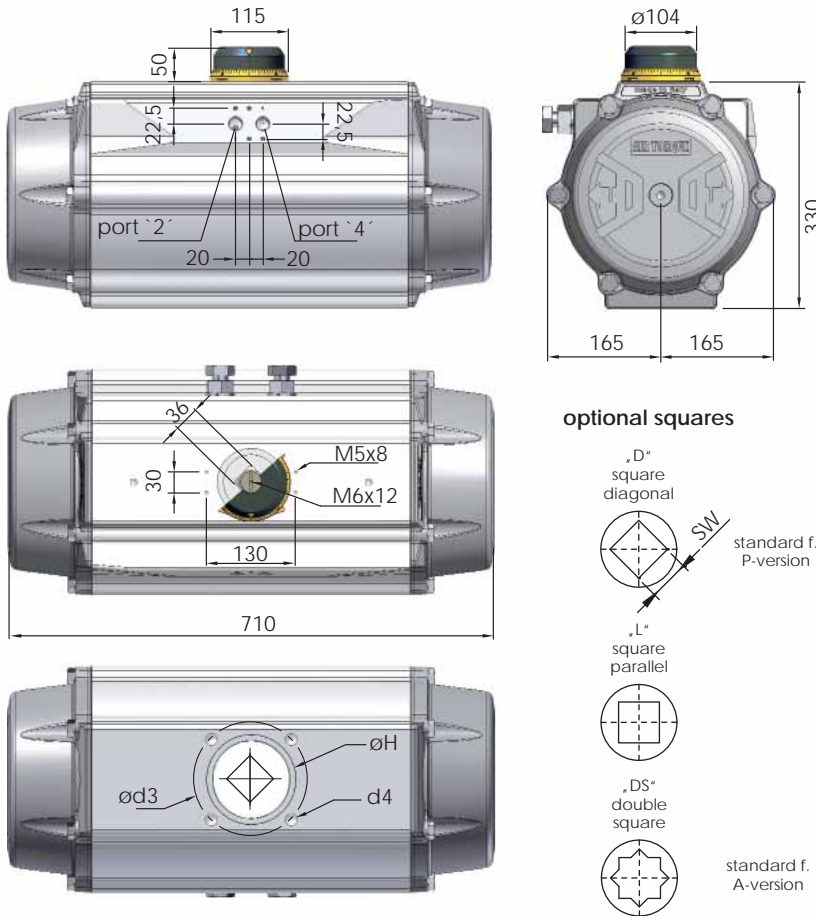

ISO 5211 - available flanges

ISO 5211	Standard		optional	
	F16	F14*	F12*	
Ø d2	130	-	-	
Ø d3	165	140	125	
d4	M20 x 30	M16 x 24	M12 x 18	
Ø H	130	112	112	
SW x l min.	D	27 x 40 - 46 x 49		
	DS	36 x 40 - 46 x 51		
h min.	2,5	2,5	2,5	
h1	1,5	-	-	

*before selecting the flange connection please consider the indications of standard n° 5211 on page 0911 of our manual for op. and maintenance

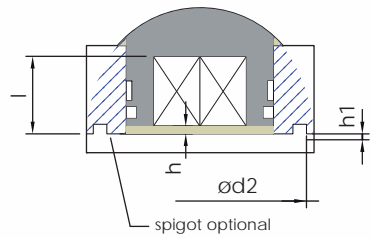

optional squares

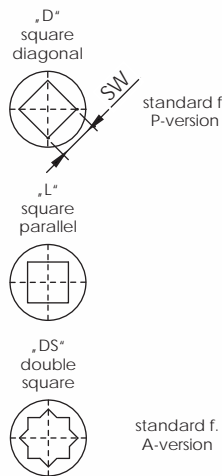

Connection / Attachment

Pressure connection port 2 and 4	G1/2"
Ancillaries attachment	AA 4

Rotation and stroke adjustment

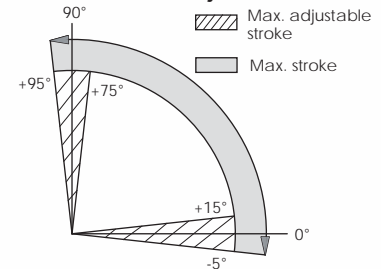

Pressure	Output Torque for Double Acting and Spring Return in Nm												Spring Torque		approx. Weight in kg										
	2,5 bar		3 bar		3,5 bar		4 bar		4,2 bar		4,5 bar		5 bar			5,5 bar		6 bar		7 bar		8 bar		90°	0°
	0°	90°	0°	90°	0°	90°	0°	90°	0°	90°	0°	90°	0°	90°		0°	90°	0°	90°	0°	90°				
DR	1297	1556	1815	2075	2179	2334	2594	2853	3112	3631	4150	801	546	84,3											

SC 2/3	751	496	1011	755	1270	1015	1529	1274	1633	1378	1789	1533	2048	1793									801	546	84,3		
SC 3	642	336	902	595	1161	854	1420	1114	1524	1217	1680	1373	1939	1632	2198	1892								961	655	85,9	
SC 3/4			792	435	1052	694	1311	954	1415	1057	1570	1213	1830	1472	2089	1732	2349	1991							1121	764	87,5
SC 4					943	534	1202	793	1306	897	1461	1053	1721	1312	1980	1571	2239	1831	2758	2350					1281	873	89,1
SC 4/5							1093	633	1197	737	1352	893	1612	1152	1871	1411	2130	1671	2649	2189	3168	2708			1442	982	90,7
SC 5											1243	732	1503	992	1762	1251	2021	1510	2540	2029	3059	2548			1602	1091	92,3
SC 5/6													1393	832	1653	1091	1912	1350	2431	1869	2950	2388			1762	1200	93,9
SC 6															1544	931	1803	1190	2322	1709	2840	2228			1922	1309	95,5

Pressure max.	Rotation (STD) (C)	Screw stroke adjustment	Chamber (Ø mm)	Air volume (L)		Moving time (sec.) (A)	
				OPEN	CLOSE	OPEN	CLOSE
8 bar	0° - 90°	for 1° 1/4 rotation	265	14,5	21,38	D 4,0 S 4,5	D 4,5 S 5,0

Operating temperature (°C) (B)		
ST (Standard)	HT (High temperature)	LLT (Extreme low temperature)
- 40 to + 80	- 15 to + 150	- 55 to + 80

(A) the above indicated moving time of the actuator is obtained under the following test conditions: (1) room temperature, (2) actuator stroke 90°, (3) solenoid valve with Ø 4 mm and flow capacity Qn 6000 L/min., (4) inside pipe Ø 11 mm, (5) medium clean air, (6) air supply pressure 5,5 bar (79,75 Psi), (7) actuator without external resistance load. **Caution:** It has to be expected, e.g. for field applications, when one or more of the above parameters are different, the moving time will be different.

Operating Medium:

The operating medium must be free of dust and oil. The maximum particle size must not exceed 30µ. (ISO 8573 Part1, Class5). In order to prevent water condensation and/or solidification (ice when actuator works below 0°C), the operating medium must have a dew point equal to -20°C or at least 10°C below the ambient temperature (ISO 8573 Part1, Class3)

(B) Every temperature range option requires proper components and lubricant. Please contact Air Torque GmbH.



Dimensions in mm

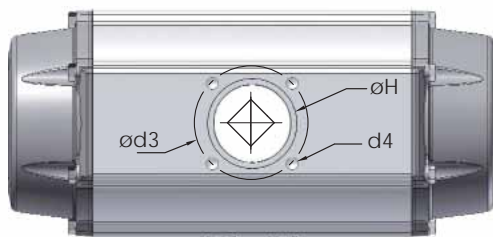
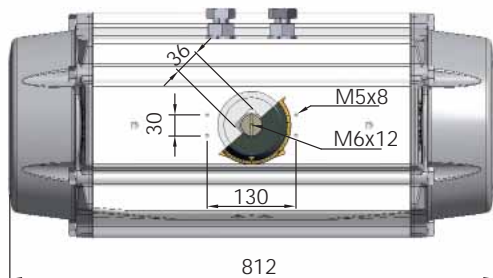
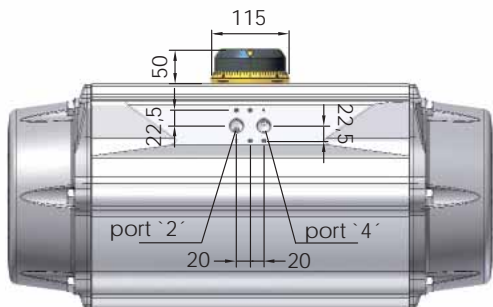

optional squares

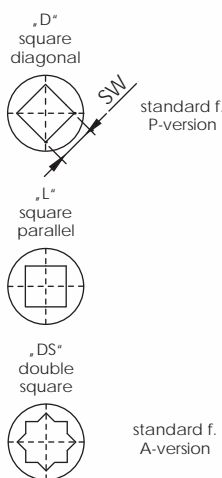

ISO 5211 - available flanges

	Standard	optional		
ISO 5211	F16*	F14*	F16* + F25	
Ø d2	130	-	130(F16) oder 200 (F25)	
Ø d3	165	140	165	254
d4	M20 x 30	M16x24	M20x30	M16x24
Ø H	130	120	130	200
SW x l min.	D	55 x 59		
	DS	46 x 51 - 55 x 60		
h min.	2,5	2,5	2,5	2,5
h1	4	-	4	4

*before selecting the flange connection please consider the indications of standard n° 5211 on page 0911 of our manual for op. and maintenance

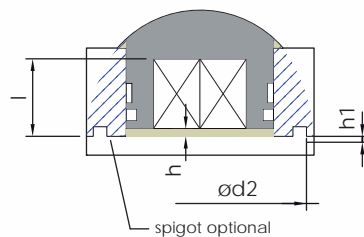

Connection / Attachment

Pressure connection port 2 and 4	G1/2"
Ancillaries attachment	AA 4

Rotation and stroke adjustment

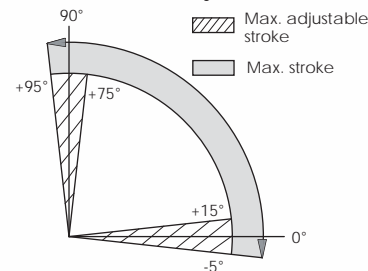

Pressure	Output torque for double acting and spring return in Nm												Spring torque	approx. weight in kg									
	2,5 bar		3 bar		3,5 bar		4 bar		4,2 bar		4,5 bar				5 bar		5,5 bar		6 bar		7 bar		8 bar
DR	1795	2154	2513	2872	3015	3231	3590	3949	4308	5026	5744												118

SC 2/3	1064	703	1423	1062	1782	1421	2141	1780	2284	1924	2500	2139	2859	2498									1092	731	131					
SC 3	918	485	1277	844	1636	1203	1995	1562	2138	1706	2354	1921	2713	2280	3072	2639									1310	877	134			
SC 3/4			1131	626	1489	985	1848	1344	1992	1487	2207	1703	2566	2062	2925	2421	3284	2780									1528	1023	137	
SC 4					1343	766	1702	1125	1846	1269	2061	1484	2420	1843	2779	2202	3138	2561	3856	3279								1746	1170	139
SC 4/5							1556	907	1700	1051	1915	1266	2274	1625	2633	1984	2992	2343	3710	3061	4428	3779						1965	1316	142
SC 5											1769	1048	2128	1407	2487	1766	2846	2125	3564	2843	4282	3560						2183	1462	145
SC 5/6													1982	1188	2341	1547	2700	1906	3418	2624	4135	3342						2401	1608	147
SC 6															2194	1329	2553	1688	3271	2406	3989	3124						2620	1754	150

Pressure max.	Rotation (STD) (C)	Screw stroke adjustment	Chamber (Ø mm)	Air volume (L)		Moving time (sec.) (A)	
				OPEN	CLOSE	OPEN	CLOSE
8 bar	0° - 90°	for 1° 1/4 rotation	300	20	33	D 5,0 S 6,0	D 6,0 S 7,0

Operating temperature (°C) (B)		
ST (Standard)	HT (High temperature)	LLT (Extreme low temperature)
- 40 to + 80	- 15 to + 150	- 55 to + 80

(A) the above indicated moving time of the actuator is obtained under the following test conditions: (1) room temperature, (2) actuator stroke 90°, (3) solenoid valve with Ø 4 mm and flow capacity Qn 6000 L/min., (4) inside pipe Ø 11 mm, (5) medium clean air, (6) air supply pressure 5,5 bar (79,75 Psi), (7) actuator without external resistance load. **Caution:** It has to be expected, e.g. for field applications, when one or more of the above parameters are different, the moving time will be different.

Operating Medium:

The operating medium must be free of dust and oil. The maximum particle size must not exceed 30µ. (ISO 8573 Part1, Class5). In order to prevent water condensation and/or solidification (ice when actuator works below 0°C), the operating medium must have a dew point equal to -20°C or at least 10°C below the ambient temperature (ISO 8573 Part1, Class3)

(B) Every temperature range option requires proper components and lubricant. Please contact Air Torque GmbH.



Dimensions in mm

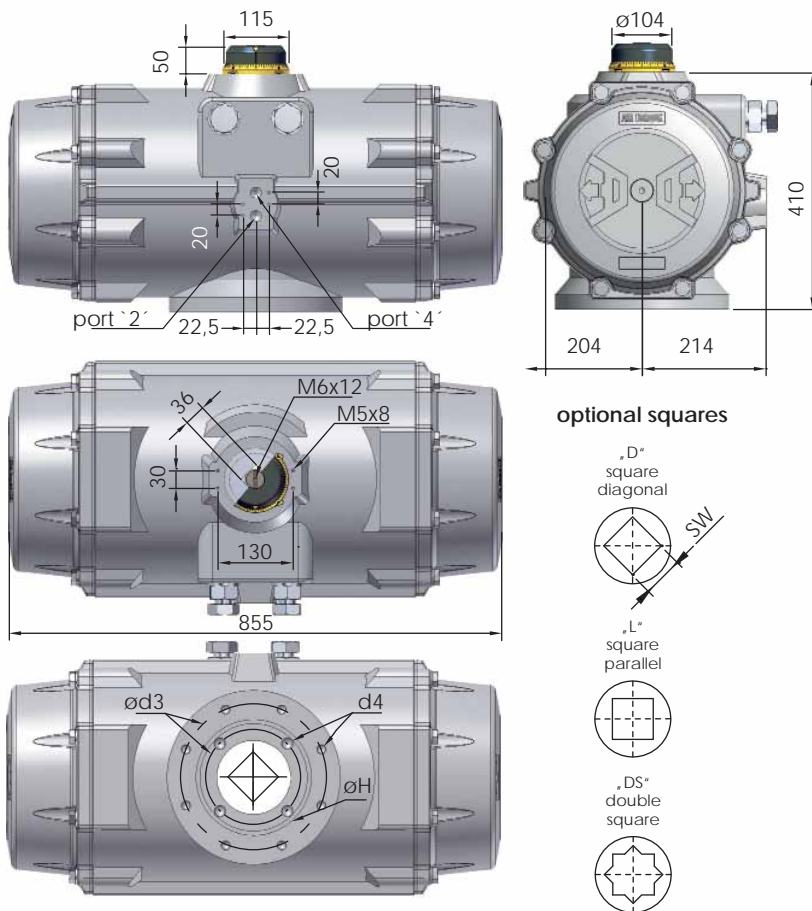

optional squares

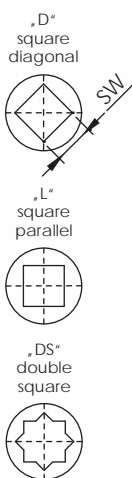

ISO 5211 - available flanges

ISO 5211	Standard		optional
	F16* + F25	F25	F25
Ø d2	-	200	200
Ø d3	165	254	254
d4	M20x30	M16x24	M16 x 24
Ø H	130	200	200
SW x l min.	D	-	55 x 59
	DS	55 x 60	46 x 51 - 55 x 60
h min.	2,5	2,5	2,5
h1	-	3,5	3,5

*before selecting the flange connection please consider the indications of standard n° 5211 on page 0911 of our manual for op. and maintenance

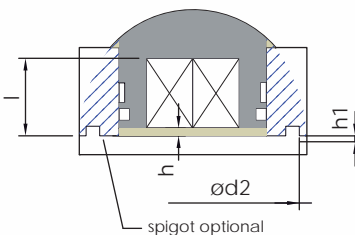

Connection / Attachment

Pressure connection port 2 and 4	G1/2"
Ancillaries attachment	AA 4

Rotation and stroke adjustment

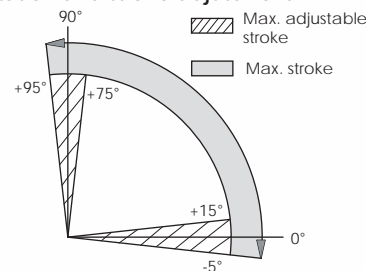

Pressure	Output torque for double acting and spring return in Nm												Spring torque	approx. weight in kg										
	2,5 bar		3 bar		3,5 bar		4 bar		4,2 bar		4,5 bar				5 bar		5,5 bar		6 bar		7 bar		8 bar	
	0°	90°	0°	90°	0°	90°	0°	90°	0°	90°	0°	90°			0°	90°	0°	90°	0°	90°	0°	90°	0°	90°
DR	2252	2703	3153	3604	3784	4054	4504	4955	5405	6306	7207	-	-	-	-	-	-	-	-	-	-	-	127	

SC 2/3	1332	1014	1783	1465	2233	1915	2684	2365	2864	2546	3134	2816	3585	3266									1238	920	144			
SC 3	1149	767	1599	1217	2049	1667	2500	2118	2680	2298	2950	2568	3401	3019	3851	3469									1486	1104	147,5	
SC 3/4			1415	969	1865	1420	2316	1870	2496	2050	2766	2321	3217	2771	3667	3222	4118	3672								1733	1288	151
SC 4					1682	1172	2132	1623	2312	1803	2582	2073	3033	2524	3483	2974	3934	3424	4835	4325						1981	1472	154,5
SC 4/5							1948	1375	2128	1555	2398	1825	2849	2276	3299	2726	3750	3177	4651	4078	5551	4978				2229	1656	158
SC 5											2215	1578	2665	2028	3115	2479	3566	2929	4467	3830	5386	4731				2476	1839	161,5
SC 5/6													2481	1781	2931	2231	3382	2682	4283	3582	5184	4483				2724	2023	165
SC 6																	2748	1983	3198	2434	4099	3335	5000	4236		2971	2207	168,5

Pressure max.	Rotation (STD) (C)	Screw stroke adjustment	Chamber (Ø mm)	Air volume (L)		Moving time (sec.) (A)	
				OPEN	CLOSE	OPEN	CLOSE
8 bar	0° - 90°	for 1° 1/4 rotation	330	25	40	D 6,0 S 7,5	D 7,0 S 8,5

Operating temperature (°C) (B)		
ST (Standard)	HT (High temperature)	LLT (Extreme low temperature)
- 40 to + 80	- 15 to + 150	- 55 to + 80

(A) the above indicated moving time of the actuator is obtained under the following test conditions: (1) room temperature, (2) actuator stroke 90°, (3) solenoid valve with Ø 4 mm and flow capacity Qn 6000 L/min., (4) inside pipe Ø 11 mm, (5) medium clean air, (6) air supply pressure 5,5 bar (79,75 Psi), (7) actuator without external resistance load. **Caution:** It has to be expected, e.g. for field applications, when one or more of the above parameters are different, the moving time will be different.

(B) Every temperature range option requires proper components and lubricant. Please contact Air Torque GmbH.

Operating Medium:

The operating medium must be free of dust and oil. The maximum particle size must not exceed 30µ. (ISO 8573 Part1, Class5). In order to prevent water condensation and/or solidification (ice when actuator works below 0°C), the operating medium must have a dew point equal to -20°C or at least 10°C below the ambient temperature (ISO 8573 Part1, Class3)

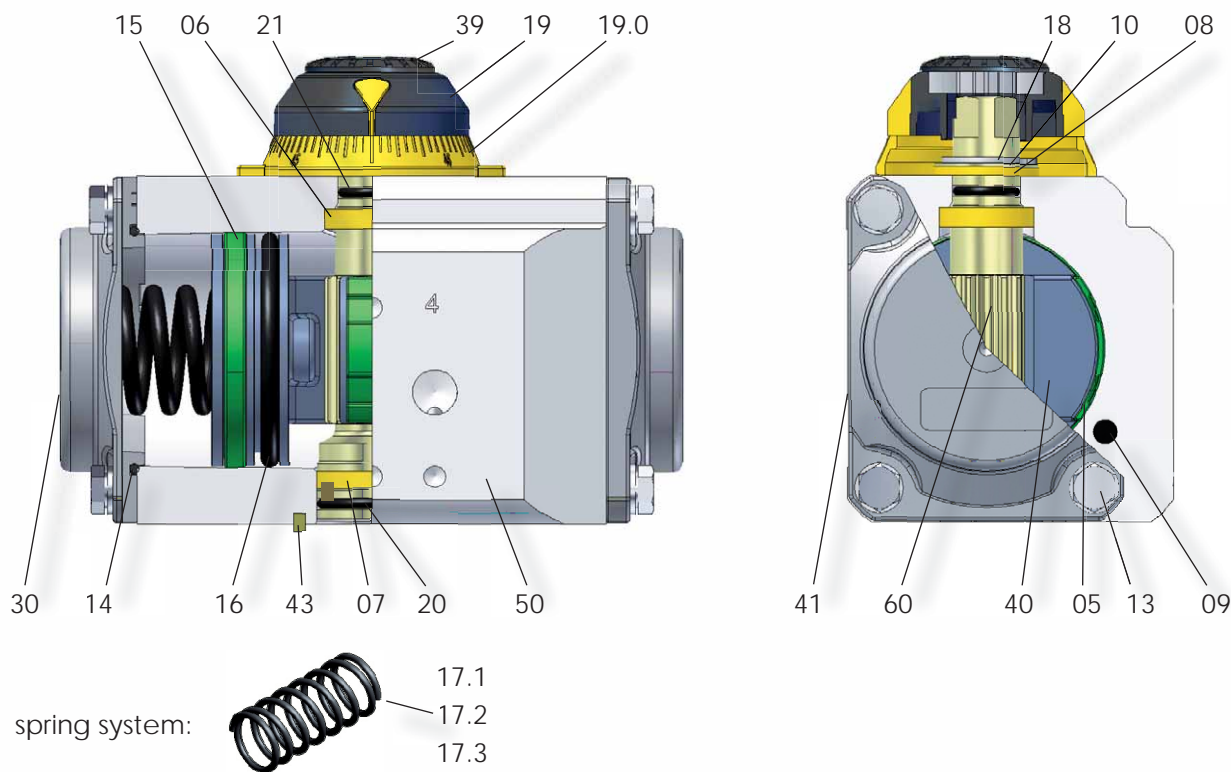

PART N°	Spare parts	UNIT	Q.TY / NOTE	PART DESCRIPTION	STANDARD MATERIAL (A) (B)
05	○	2		BEARING (Piston back)	PA46
06	○	1		BEARING (Pinion top)	PA46
07	○	1		BEARING (Pinion bottom)	PA46
08	○	1		THRUST BEARING (Pinion)	PA46
09	○ ⊕	2		PLUG	Silicone
10		1		THRUST WASHER (Pinion)	Stainless Steel
13		8		CAP SCREW (End cap)	Stainless Steel
14	○ ⊕	2		"O" RING (End cap)	M-NBR
15	○	2		BEARING (Piston head)	POM
16	○ ⊕	2		"O" RING (Piston)	M-NBR
17.1				SPRING	
17.2		max. 2		SPRING	Si Cr Spring alloy Steel expoy coated
17.3				SPRING	
18		1		SPRING CLIP (Pinion)	Spring Steel, ENP
19		1		POSITION INDICATOR	PA66+GF+CB
19.0		1		GRADUATED RING	PA66+GF(+CB)
20	○ ⊕	1		"O" RING (Pinion bottom)	M-NBR
21	○ ⊕	1		"O" RING (Pinion top)	M-NBR
30		2		END CAP	Pressure Die Cast Aluminium alloy, anodized and coated
39		1		CAP SCREW (Indicator)	PA66+GF+CB
40		2		PISTON	Pressure Die Cast Aluminium alloy, anodized
41		1		ACTUATOR IDENTIFICATION LABEL	Polyester-Silver
42		2		END CAP LABEL	Polyester-Silver
43		1		SPIGOT (Only on request)	Extruded Aluminium alloy, anodized
50		1		BODY	Extruded Aluminium alloy, coated
60		1		DRIVE SHAFT	Extruded Alluminium alloy, anodized
60.1		1	only f prot. level E a. EC	INTEGRAL DRIVE SHAFT	Stainless Steel, ENP

○ Parts included in Complete spare parts kit ⊕ Parts included in „O“ ring spare parts kit



EDITION 2010
Part Description
DR/SC00015U-00030U

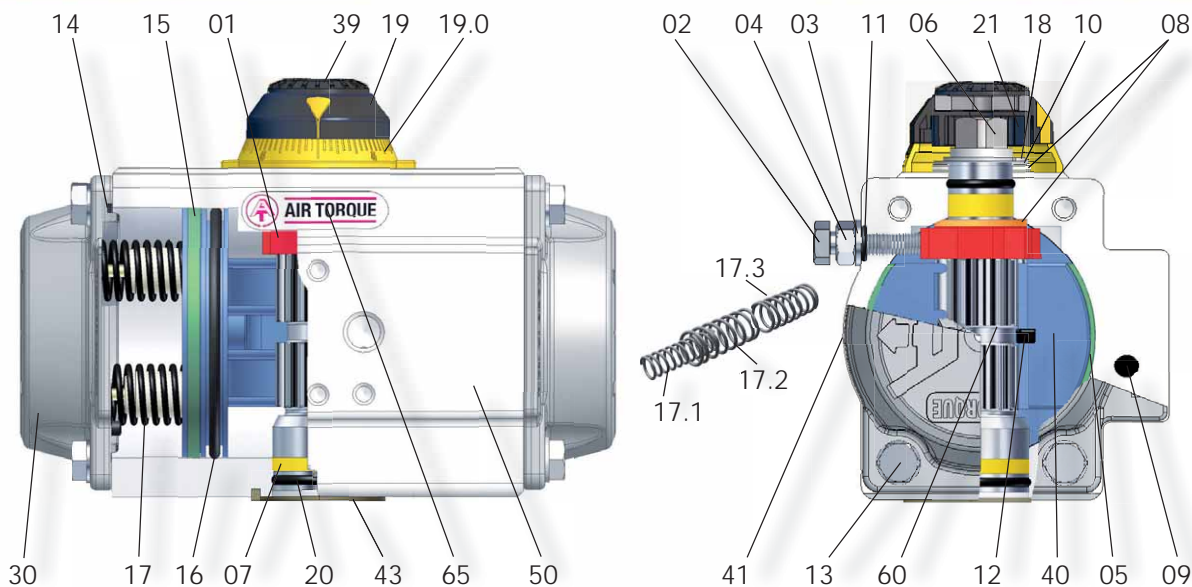

PART N°	Spare parts	UNIT Q.TY / NOTE	PART DESCRIPTION	STANDARD MATERIAL (A) (B)
01		1	OCTI-CAM (Stop arrangement)	Stainless Steel
02		2	STOP CAP SCREW	Stainless Steel
03		2	WASHER	Stainless Steel
04		2	NUT (Stop screw)	Stainless Steel
05	○	2	BEARING (Piston back)	PA46
06	○	1	BEARING (Pinion top)	PA46
07	○	1	BEARING (Pinion bottom)	PA46
08	○	1	THRUST BEARING (Pinion)	PA46
09	○ ⊕	2	PLUG	Silicone
10		1	THRUST WASHER (Pinion)	Stainless Steel
11	○ ⊕	2	"O" RING (Stop screw)	M-NBR
12		2	PISTON GUIDE	PA66+GF
13		8	CAP SCREW (End cap)	Stainless Steel
14	○ ⊕	2	"O" RING (End cap)	M-NBR
15	○	2	BEARING (Piston head)	POM
16	○ ⊕	2	"O" RING (Piston)	M-NBR
17		min.2 max.4	SPRING (Cartridge)	SiCr Spring alloy Steel epoxy coated
17.1			SPRING	
17.2		min.2 max.4	SPRING	
17.3			SPRING	
18		1	SPRING CLIP (Pinion)	Spring Steel, ENP
19		1	POSITION INDICATOR	PA66+GF+CB
19.0		1	GRADUATED RING	PA66+GF(+CB)
20	○ ⊕	1	"O" RING (Pinion bottom)	M-NBR
21	○ ⊕	1	"O" RING (Pinion top)	M-NBR
30		2	END CAP	Pressure Die Cast Aluminium alloy, anodized and coated
39		1	CAP SCREW (Indicator)	PA66+GF+CB
40		2	PISTON	Pressure Die Cast Aluminium alloy, anodized
41		1	ACTUATOR IDENTIFICATION LABEL	Polyester-Silver
43		1	SPIGOT (Only on request)	Extruded Aluminium alloy, anodized
50		1	BODY	Extruded Aluminium alloy, coated
60		1	DRIVE SHAFT	Steel, ENP
60.1		1 only f prot. level E a. EC	INTEGRAL DRIVE SHAFT	Stainless Steel, ENP
65		1	PLASTIC INSERT	Modified PA66

○ Parts included in Complete spare parts kit ⊕ Parts included in „O" ring spare parts kit



EDITION 2010
Part Description
DR/SC0060U-02000U

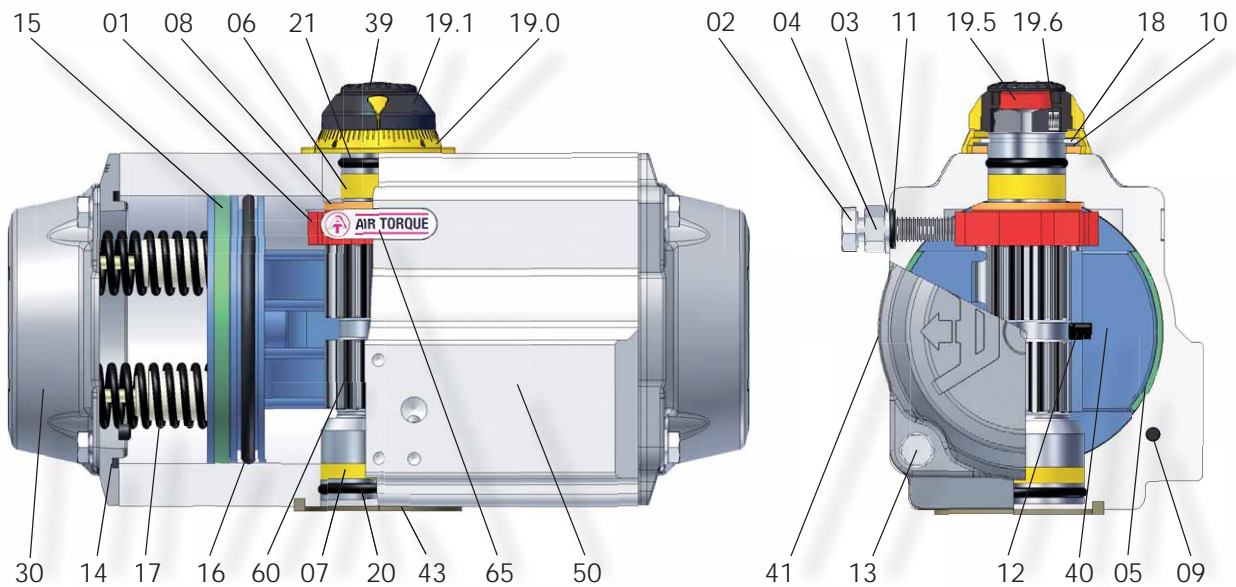

PART N°	Spare parts	UNIT Q.TY / NOTE	PART DESCRIPTION	STANDARD MATERIAL (A) (B)
01		1	OCTI-CAM (Stop arrangement)	Stainless Steel (for AT201U , AT301U) Carbon Steel (for AT351U y AT651U) , zinc coated
02		2	STOP CAP SCREW	Stainless Steel
03		2	WASHER	Stainless Steel
04		2	NUT (Stop screw)	Stainless Steel
05	○	2	BEARING (Piston back)	PA46
06	○	1	BEARING (Pinion top)	High-grade polymers
07	○	1	BEARING (Pinion bottom)	High-grade polymers
08	○	1	THRUST BEARING (Pinion)	PA46
09	○ ⊕	2	PLUG	Silicone
10		1	THRUST WASHER (Pinion)	Stainless Steel
11	○ ⊕	2	"O" RING (Stop screw)	M-NBR
12		2	PISTON GUIDE	PA66+GF
13		8	CAP SCREW (End cap)	Stainless Steel
14	○ ⊕	2	"O" RING (End cap)	M-NBR
15	○	2	BEARING (Piston head)	POM
16	○ ⊕	2	"O" RING (Piston)	M-NBR
17		min.05 max.12	SPRING (Cartridge)	SiCr Spring alloy Steel epoxy coated
18		1	SPRING CLIP (Pinion)	Spring Steel, ENP
19.0		1	GRADUATED RING	PA66+GF+CB
19.1		1	POSITION INDICATOR	PA66+GF+(CB)
19.5		1	TOP ADAPTOR	Extruded Aluminium alloy, anodized
19.6		2	HEX. SOCKET SCREW (Top Adaptor)	Stainless Steel
20	○ ⊕	1	"O" RING (Pinion bottom)	M-NBR
21	○ ⊕	1	"O" RING (Pinion top)	M-NBR
30		2	END CAP	Pressure Die Cast Aluminium alloy, anodized and coated
39		1	CAP SCREW (Indicator)	PA66+GF+CB
40		2	PISTON	Pressure Die Cast Aluminium alloy, anodized
41		1	ACTUATOR IDENTIFICATION LABEL	Polyester-Silver
43		1	SPIGOT (Only on request)	Extruded Aluminium alloy, anodized
50		1	BODY	Extruded Aluminium alloy, coated
60		1	DRIVE SHAFT	Steel, ENP
60.1		1	only f. prot. level E a. EC INTEGRAL DRIVE SHAFT	Stainless Steel, ENP
65		1	PLASTIC INSERT	Modified PA66

○ Parts included in Complete spare parts kit ⊕ Parts included in „O“ ring spare parts kit



EDITION 2010
Part Description
DR/SC03000U-04000U

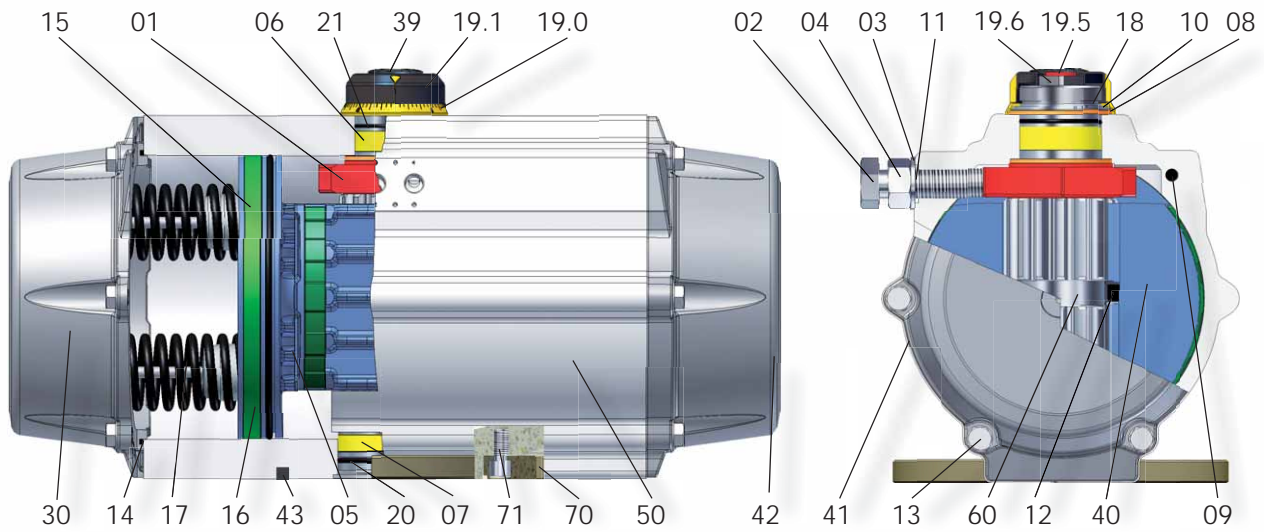

PART N°	Spare parts	UNIT Q.TY / NOTE	PART DESCRIPTION	STANDARD MATERIAL (A) (B)
01		1	OCTI-CAM (Stop arrangement)	Carbon Steel, zinc coated
02		2	STOP CAP SCREW	Stainless Steel
03		2	WASHER	Stainless Steel
04		2	NUT (Stop screw)	Stainless Steel
05	○	2	BEARING (Piston back)	PA46
06	○	1	BEARING (Pinion top)	High-grade polymers
07	○	1	BEARING (Pinion bottom)	High-grade polymers
08	○	1	THRUST BEARING (Pinion)	PA46
09	○ ⊕	2	*O-RING* PLUG	Silicone
10		1	THRUST WASHER (Pinion)	Stainless Steel
11	○ ⊕	2	*O* RING (Stop screw)	M-NBR
12		2	PISTON GUIDE	PA66+GF
13		8	CAP SCREW (End cap)	Stainless Steel
14	○ ⊕	2	*O* RING (End cap)	M-NBR
15	○	2	BEARING (Piston head)	POM
16	○ ⊕	2	*O* RING (Piston)	M-NBR
17		min.05 max.12	SPRING (Cartridge)	SiCr Spring alloy Steel epoxy coated
18		1	SPRING CLIP (Pinion)	Spring Steel, ENP
19.0		1	GRADUATED RING	PA66+GF(+CB)
19.1		1	POSITION INDICATOR	PA66+GF+CB
19.5		1	TOP ADAPTOR	Extruded Aluminium alloy, anodized
19.6		2	HEX. SOCKET SCREW (Top Adaptor)	Stainless Steel
20	○ ⊕	1	*O* RING (Pinion bottom)	M-NBR
21	○ ⊕	1	*O* RING (Pinion top)	M-NBR
30		2	END CAP	Pressure Die Cast Aluminium alloy, anodized and coated
39		1	CAP SCREW (Indicator)	PA66+GF+CB
40		2	PISTON	Pressure Die Cast Aluminium alloy, anodized
41		1	ACTUATOR IDENTIFICATION LABEL	Polyester-Silver
42		1 only for DRSC4000U	END CAP LABEL	Polyester-Silver
43		1	SPIGOT (Only on request)	Extruded Aluminium alloy, anodized
50		1	BODY	Extruded Aluminium alloy, coated
60		1	DRIVE SHAFT	Steel, ENP
60.1		1 only f. prot. level E a. EC	INTEGRAL DRIVE SHAFT	Stainless Steel, ENP
65		1 only for DRSC3000U	PLASTIC INSERT	Modified PA66
70		1 only for DRSC4000U	FLANGE (Optional only for F25 or F16+F25)	Extruded Aluminium alloy, anodized
71		4 only for DRSC4000U	SOCKET HEAD CAP SCREW (Flange)	Stainless Steel

○ Parts included in Complete spare parts kit ⊕ Parts included in „O“ ring spare parts kit



EDITION 2010
Part Description
DR/SC05000U

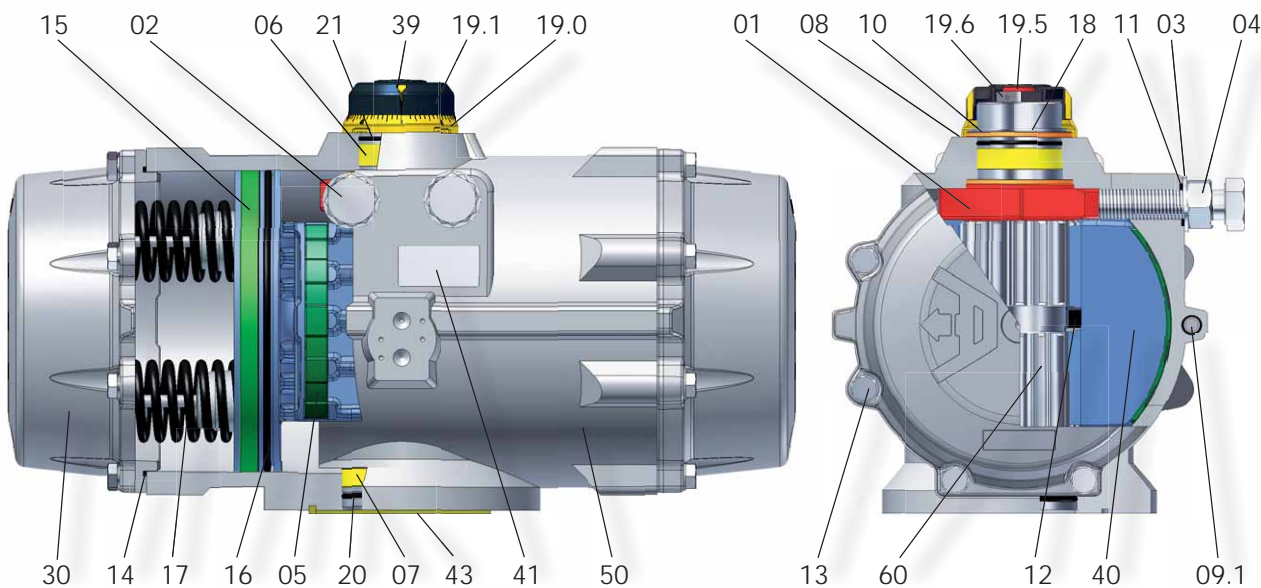

PART N°	Spare Parts	UNIT Q.TY / NOTE	PART DESCRIPTION	STANDARD MATERIAL (A) (B)
01		1	OCTI-CAM (Stop arrangement)	Carbon Steel, zinc coated
02		2	STOP CAP SCREW	Stainless Steel
03		2	WASHER	Stainless Steel
04		2	NUT (Stop screw)	Stainless Steel
05	○	2	BEARING (Piston back)	PA46
06	○	1	BEARING (Pinion top)	High-grade polymers
07	○	1	BEARING (Pinion bottom)	High-grade polymers
08	○	2	THRUST BEARING (Pinion)	PA46
09.1	○ ⊕	2	"O-RING" PLUG	M-NBR
10		1	THRUST WASHER (Pinion)	Stainless Steel
11	○ ⊕	2	"O" RING (Stop screw)	M-NBR
12		2	PISTON GUIDE	PA66+GF
13		8	CAP SCREW (End cap)	Stainless Steel
14	○ ⊕	2	"O" RING (End cap)	M-NBR
15	○	2	BEARING (Piston head)	POM
16	○ ⊕	2	"O" RING (Piston)	M-NBR
17		min.05 max.12	SPRING (Cartridge)	SiCr Spring alloy Steel epoxy coated
18		1	SPRING CLIP (Pinion)	Spring Steel, ENP
19.0		1	GRADUATED RING	PA66+GF(+CB)
19.1		1	POSITION INDICATOR	PA66+GF+CB
19.5		1	TOP ADAPTOR	Extruded Aluminium alloy, anodized
19.6		2	HEX. SOCKET SCREW (Top Adaptor)	Stainless Steel
20	○ ⊕	1	"O" RING (Pinion bottom)	M-NBR
21	○ ⊕	1	"O" RING (Pinion top)	M-NBR
30		2	END CAP	Pressure Die Cast Aluminium alloy, anodized and coated
39		1	CAP SCREW (Indicator)	PA66+GF+CB
40		2	PISTON	Pressure Die Cast Aluminium alloy, anodized
41		1	ACTUATOR IDENTIFICATION LABEL	Polyester-Silver
43		1	SPIGOT (Only on request)	Extruded Aluminium alloy, anodized
50		1	BODY	Cast Aluminium alloy, coated
60		1	DRIVE SHAFT	Steel, ENP
60.1		1	only f. prot. level E / EC INTEGRAL DRIVE SHAFT	Stainless Steel, ENP

○ Parts included in Complete spare parts kit ⊕ Parts included in „O“ ring spare parts kit



EDITION 2010
Part Description
DR/SC10000U

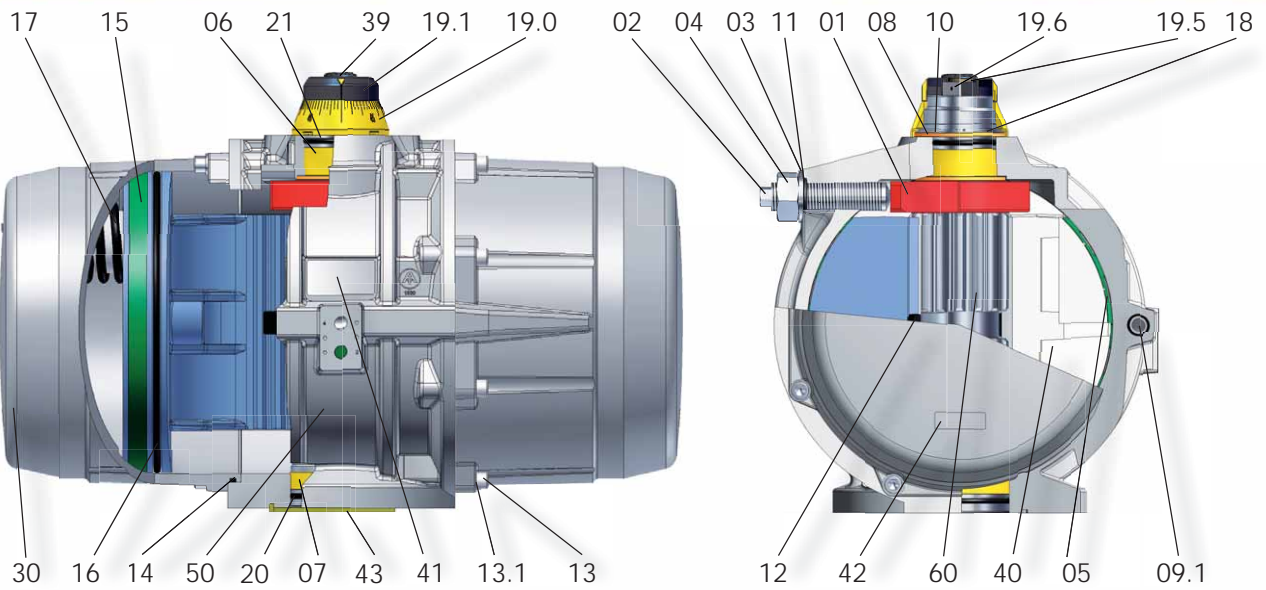

PART N°	Spare Parts	UNIT Q.TY / NOTE	PART DESCRIPTION	STANDARD MATERIAL (A) (B)
01		1	OCTI-CAM (Stop arrangement)	Nodular Cast Iron, zinc coated
02		2	ANTI BLOW OUT STOP SCREW	Stainless Steel
03		2	WASHER	Stainless Steel
04		2	NUT (Stop screw)	Stainless Steel
05	○	4	BEARING (Piston back)	PA46
06	○	1	BEARING (Pinion top)	High-grade polymers
07	○	1	BEARING (Pinion bottom)	High-grade polymers
08	○	2	THRUST BEARING (Pinion)	PA46
09.1	○ ⊕	2	"O-RING" PLUG	M-NBR
10		1	THRUST WASHER (Pinion)	Stainless Steel
11	○ ⊕	2	"O" RING (Stop screw)	M-NBR
12		2	PISTON GUIDE	PA66
13		16	CAP SCREW (End cap)	Stainless Steel
13.1		16	WASHER (Cap Screw end cap)	Stainless Steel
14	○ ⊕	2	"O" RING (End cap)	M-NBR
15	○	2	BEARING (Piston head)	POM
16	○ ⊕	2	"O" RING (Piston)	M-NBR
17		min.05 max.12	SPRING (Cartridge)	SiCr Spring alloy Steel epoxy coated
18		1	SPRING CLIP (Pinion)	Spring Steel, ENP
19.0		1	GRADUATED RING	PA66+GF(+CB)
19.1		1	POSITION INDICATOR	PA66+GF+CB
19.5		1	TOP ADAPTOR	Extruded Aluminium alloy, anodized
19.6		2	HEX. SOCKET SCREW (Top Adaptor)	Stainless Steel
20	○ ⊕	1	"O" RING (Pinion bottom)	M-NBR
21	○ ⊕	1	"O" RING (Pinion top)	M-NBR
30		2	END CAP	Cast Aluminium alloy, anodized and coated
39		1	CAP SCREW (Indicator)	PA66+GF+CB
39.1		1	WASHER (Indicator)	Stainless Steel
40		2	PISTON	Cast Aluminium alloy, anodized
41		1	ACTUATOR IDENTIFICATION LABEL	Polyester-Silver
42		2	END CAP LABEL	Polyester-Silver
43		1	SPIGOT (Only on request)	Extruded Aluminium alloy, anodized
50		1	BODY	Cast Aluminium alloy, coated
60		1	DRIVE SHAFT	Extruded Aluminium alloy, anodized
60.1		1 only f. prot. level E / EC	INTEGRAL DRIVE SHAFT	Stainless Steel, ENP

○ Parts included in Complete spare parts kit ⊕ Parts included in „O“ ring spare parts kit



EDITION 2010
Dimensions
DR/SC00010U-10000U



AIR TORQUE
PNEUMATISCHE STELLANTRIEBE

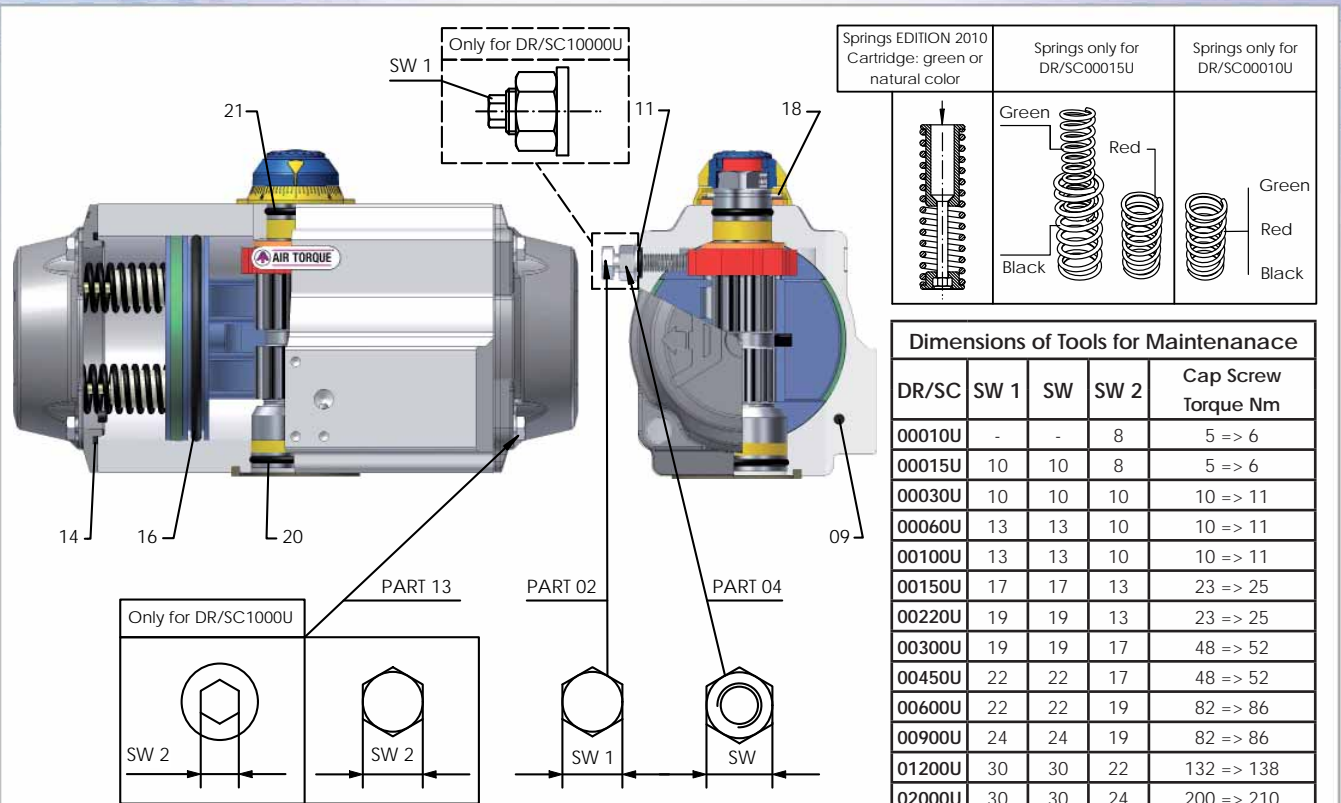

Note:
Dimensions in [mm]
(A) Type 03000-04000 -> 12 cap screws; Type 05000-10000 -> 16 cap screws (end cap).

Part No.	St.	Description	DR/SC 00010U	DR/SC 00015U	DR/SC 00030U	DR/SC 00060U	DR/SC 00100U	DR/SC 00150U	DR/SC 00220U	DR/SC 00300U	DR/SC 00450U
2	2	Stop cap screw	-	M6x24	M6x28	M8x31.5	M8x34	M10x41	M12x49		M14x55
4	2	Nut (Stop screw)	-	M6		M8		M10	M12		M14
9*	2	Plug	Non standard special part								
11*	2	O-Ring (Stop screw)	-	5,28x1,78		7,6x2,62		9,92x2,62	10,69x3,53		13,87x3,53
13(A)	8	Cap screw (End cap)	M5x30		M6x25			M8x30		M10x35	
14*	2	O-Ring (End cap)	44,17x1,78	47,35x1,78	60,05x1,78	72,70x2,62	83,8x2,62	97x2,6	113,9x3,53	123,42x3,53	142,5x3,53
16*	2	O-Ring (Piston)	37,7x3,53	42,86x3,53	56,75x3,53	68,26x3,53	75,57x5,34	86,69x5,34	104,14x5,34	113,67x5,34	129,54x6,99
18	1	Ø of spring clip DIN471	13	14	16	22	25	26	36	38	45
20*	1	O-Ring (Pinion bottom)	17,16x1,78		20,35x1,78	26,65x2,62	33x2,62	34,6x2,62	44,12x2,62	48,9x2,62	55,56x3,53
21*	1	O-Ring (Pinion top)	9,25x1,78	10,82x1,78	12,42x1,78	17,13x2,62	20,29x2,62	21,9x2,62	29,82x2,62	33x2,62	37,7x3,53

Part No.	St.	Description	DR/SC 00600U	DR/SC 00900U	DR/SC 01200U	DR/SC 02000U	DR/SC 03000U	DR/SC 04000U	DR/SC 05000U	DR/SC 10000U		
2	2	Stop cap screw	M14x55	M16x68.5	M20x77	M20x85.5	M24x94	M30x108	M30x129	M39x178		
4	2	Nut (Stop screw)	M14	M16	M20		M24	M30		M39		
9*	2	Plug	Non standard special part								18,64x3,53	23,17x5,34
11*	2	O-Ring (Stop screw)	13,87x3,54	15,47x3,53	18,42x5,34		21,59x5,34	27,94x5,34		34,47x6,99		
13 (A)	8	Cap screw (End cap)	M12x50		M14x55	M16x60	M14x55	M16x60		M16x70		
14*	2	O-Ring (End cap)	158,35x3,53	177,4x3,53	196,45x3,53	234,3x5,34	253,4x5,34	291,47x5,34	304,17x5,34	417,96x6,99		
16*	2	O-Ring (Piston)	145,42x6,99	166,7x6,99	183,5x6,99	221,6x6,99	247x6,99	285,1x6,99	310,5x6,99	390x10		
18	1	Ø of spring clip DIN471	48	52	58	68	80	85	90	102		
20*	1	O-Ring (Pinion bottom)	59,92x3,53	63,1x3,53	69,22x5,34	81,92x5,34	100x5,34	109,54x5,34	116,84x5,34	129,54x6,99		
21*	1	O-Ring (Pinion top)	40,87x3,53	44,45x3,53	47x5,34	56,52x5,34	62,22x5,34	74,63x5,34	78,74x5,34	88,27x6,99		



Actuator Sizes German
Valve attachment

Actuator Sizes international

Type	Flange ISO 5211	Double Square	Square	Type Marking
DR/SC 00010U	F03 / F04	9 / 11	-	AT 045
DR/SC 00015U	F03F05 / F04	11	9 / 11	AT 051U
DR/SC 00030U	F03F05 / F04F07 / F05F07 / F05	11 / 14	9 / 14	AT 101U
DR/SC 00060U	F04F07 / F05F07 / F05	14 / 17	11 / 14 / 17	AT 201U
DR/SC 00100U	F05F07 / F07	17	11 / 14 / 17	AT 251U
DR/SC 00150U	F05F07 / F07F10 / F07	17 / 22	14 / 17 / 22	AT 301U
DR/SC 00220U	F07F10 / F10	17 / 22	14 / 22	AT 351U
DR/SC 00300U	F07F10 / F10	22 / 27	17 / 22	AT 401U
DR/SC 00450U	F10F12 / F12	27	22 / 27	AT 451U
DR/SC 00600U	F10F12 / F12	27	22 / 27	AT 501U
DR/SC 00900U	F10F12 / F14	27 / 36	22 / 36	AT 551U
DR/SC 01200U	F10F12 / F14	27 / 36	22 / 36	AT 601U
DR/SC 02000U	F12 / F14 / F16	36 / 46	27 / 46	AT 651U
DR/SC 03000U	F12 / F14 / F16	36 / 46	27 / 46	AT 701U
DR/SC 04000U	F14 / F16 / F16F25	46 / 55	55	AT 751U
DR/SC 05000U	F16F25 / F25	46 / 55	55	AT 801U
DR/SC 10000U	F16F25F30 / F30	55 / 75	75	AT 1004U

- Standard bold printet
- all types except P version with double flange in some sizes + double square
- Version P P only available with single flange and square
- EC Version only available with stainless steel drive shaft and double square

How to order:

Pos.1: Actuator type - Feature 1

D - double acting
S - single acting

Pos.2: Actuator type - Feature 2

R - Clockwise (CW) > for double acting actuators
L - CounterCW >
C - Spring close > for single acting actuators
O - Spring open >

Pos.3: Size

last digit = 0 -> turning range 90°
last digit = 2 -> turning range 120°
last digit = 3 -> turning range 135°
last digit = 5 -> turning range 145°
last digit = 8 -> turning range 180°

Pos.4: Number of springs per side

only for single acting actuators

Pos.5: Actuator type - Feature 3

U (Upgrade) = Edition 2010
without attribute = Edition 2000

Pos.6: Flange Connection

possible combinations -> s. top table

Pos.7: Key Size

possible combinations -> s. top table

Pos.8: Protection Levels

Versions: A/B/D/E/P/EC/S*

Pos.9: Cam

without attribute = conical cam with graduated ring
Z (cylindric) = multifunktional indicator

Pos.10: Special Attributes

3 - 3 position
B - 100% or 50% stroke adjustment
D - hydraulic damper
F - special colour
FM - Fail Mid
H - high temperature
N - internal character
Q - for assembly across the line
S - fast acting
T - extreme low temperature
W - control medium clean water
Y - centerring*
G - automatic safety device**

Ordering Example:

Position	1	2	3	4	5	6	7	8	9	10
Example	S	C	00100	-4	U	F05F07	17	A	Z	H

Single acting actuator, spring close, size 00100, 4 springs per side (symmetric sizing for control pressure = 4bar), Edition 2010, double flange F05F07, double square 17, version A, multifunction indicator, high temperature

*Details for S = stainless steel see data sheet 0306 / 0524

**not for P-Version, included in standard version

***on request for some sizes



Air Consumption of AT-Actuators with 90° turning angle in litre/stroke

Actuator		Air Supply Pressure P _e in bar									
		2.5	3	3.5	4	4.5	5	5.5	6	7	8
00006	DR	0,18	0,20	0,23	0,25	0,28	0,30	0,33	0,35	0,40	0,45
	SC/SO	0,07	0,08	0,09	0,10	0,11	0,12	0,13	0,14	0,16	0,18
00010	DR	0,56	0,64	0,72	0,80	0,88	0,96	1,04	1,12	1,28	1,44
	SC/SO	0,21	0,24	0,27	0,30	0,33	0,36	0,39	0,42	0,48	0,54
00015	DR	0,84	0,96	1,08	1,20	1,32	1,44	1,56	1,68	1,92	2,16
	SC/SO	0,32	0,36	0,41	0,45	0,50	0,54	0,59	0,63	0,72	0,81
00030	DR	1,47	1,68	1,89	2,10	2,31	2,52	2,73	2,94	3,36	3,78
	SC/SO	0,56	0,64	0,72	0,80	0,88	0,96	1,04	1,12	1,28	1,44
00060	DR	2,80	3,20	3,60	4,00	4,40	4,80	5,20	5,60	6,40	7,20
	SC/SO	1,09	1,24	1,40	1,55	1,71	1,86	2,02	2,17	2,48	2,79
00100	DR	4,52	5,16	5,81	6,45	7,10	7,74	8,39	9,03	10,32	11,61
	SC/SO	1,79	2,04	2,30	2,55	2,81	3,06	3,32	3,57	4,08	4,59
00150	DR	6,37	7,28	8,19	9,10	10,01	10,92	11,83	12,74	14,56	16,38
	SC/SO	2,49	2,84	3,20	3,55	3,91	4,26	4,62	4,97	5,68	6,39
00220	DR	10,47	11,96	13,46	14,95	16,45	17,94	19,44	20,93	23,92	26,91
	SC/SO	4,17	4,76	4,76	5,95	6,55	7,14	7,74	8,33	9,52	9,52
00300	DR	13,58	15,52	17,46	19,40	21,34	23,28	25,22	27,16	31,04	34,92
	SC/SO	5,39	6,16	6,93	7,70	8,47	9,24	10,01	10,78	12,32	13,86
00450	DR	21,67	24,76	27,86	30,95	34,05	37,14	40,24	43,33	49,52	55,71
	SC/SO	8,44	9,64	10,85	12,05	13,26	14,46	15,67	16,87	19,28	21,69
00600	DR	28,21	32,24	36,27	40,30	44,33	48,36	52,39	56,42	64,48	72,54
	SC/SO	10,99	12,56	14,13	15,70	17,27	18,84	20,41	21,98	25,12	28,26
00900	DR	39,03	44,60	50,18	55,75	61,33	66,90	72,48	78,05	89,20	100,35
	SC/SO	14,91	17,04	19,17	21,30	23,43	25,56	27,69	29,82	34,08	38,34
01200	DR	53,90	61,60	69,30	77,00	84,70	92,40	100,10	107,80	123,20	138,60
	SC/SO	20,79	23,76	26,73	29,70	32,67	35,64	38,61	41,58	47,52	53,46
02000	DR	88,20	100,80	113,40	126,00	138,60	151,20	163,80	176,40	201,60	226,80
	SC/SO	35,00	40,00	45,00	50,00	55,00	60,00	65,00	70,00	80,00	90,00
03000	DR	125,58	143,52	161,46	179,40	197,34	215,28	233,22	251,16	287,04	322,92
	SC/SO	50,75	58,00	65,25	72,50	79,75	87,00	94,25	101,50	116,00	130,50
04000	DR	185,50	212,00	238,50	265,00	291,50	318,00	344,50	371,00	424,00	477,00
	SC/SO	70,00	80,00	90,00	100,00	110,00	120,00	130,00	140,00	160,00	180,00
05000	DR	227,50	260,00	292,50	325,00	357,50	390,00	422,50	455,00	520,00	585,00
	SC/SO	87,50	100,00	112,50	125,00	137,50	150,00	162,50	175,00	200,00	225,00
10000	DR	465,50	532,00	598,50	665,00	731,50	798,00	864,50	931,00	1064,00	1197,00
	SC/SO	171,50	196,00	220,50	245,00	269,50	294,00	318,50	343,00	392,00	441,00

Calculation:

$Q = n \cdot V \cdot (p_e + p_{amb}) / p_{amb}$; Q = air consumption; n = Cycles; p_e = control pressure; p_{amb} = air pressure

Definition Stroke:

DR -> 1 stroke corresponds to 1 x OPEN (0°-90°) and 1 x CLOSE (90°-0°)

SC -> 1 stroke corresponds to 1 x OPEN (0°-90°); CLOSE (90°-0°) with springs

Air Consumption of AT-Actuators with 90° turning angle in m³/stroke

conversion: 1L = 0,001 m³ / 1000L = 1m³

Actuator		Air Supply Pressure P _e in bar									
		2.5	3	3.5	4	4.5	5	5.5	6	7	8
00006	DR	0,00018	0,0002	0,00023	0,00025	0,00028	0,0003	0,00033	0,00035	0,0004	0,00045
	SC/SO	0,00007	0,00008	0,00009	0,0001	0,00011	0,00012	0,00013	0,00014	0,00016	0,00018
⋮	⋮	⋮	⋮	⋮	⋮	⋮	⋮	⋮	⋮	⋮	⋮
10000	DR	0,4655	0,532	0,5985	0,665	0,7315	0,798	0,8645	0,931	0,1064	0,1197
	SC/SO	0,1715	0,196	0,2205	0,245	0,2695	0,294	0,3185	0,343	0,392	0,441

EXTRACT FROM THE TABLE FOR PURPOSE OF EXAMPLIFICATION OF THE CONVERSION



EDITION 2010
Actuators 120°, 135° a. 180°
DR00015U - 04000U



AIR TORQUE

PNEUMATISCHE STELLANTRIEBE

Design: **DOUBLE ACTING**

Dimensions
in mm

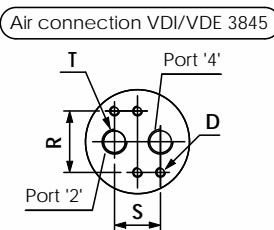
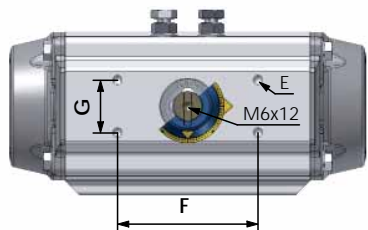
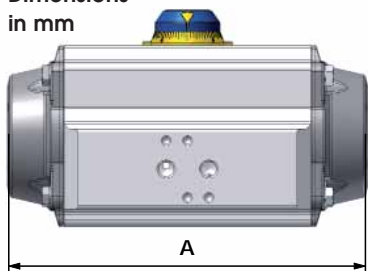

Bottom View ISO 5211

Position of Square
Actuator position CLOSE (0°)

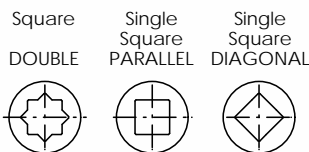

Square drive shaft top

for type
DR00015U
DR00030U

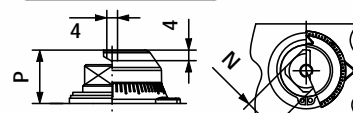

for type
DR00060U
DR04000U

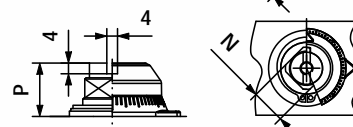

Actuator	Type	A	B	C	D	F	G	N	P	R	S	T - ISO 228	Z1	Q	Q1	W	W1	*ISO Flange	ca. Weight in kg
DR00012U	120°	153	69	72	M5x8	80	30	11	20	32	24	1/8"	42	42	-	M5	-	F04	1,24
DR00013U	135°	165																	1,4
DR00018U	180°	192																	1,57
DR00032U	120°	172	85	84,5	M5x8	80	30	11	20	32	24	1/8"	42	50	70	M6	M8	F05 + F07	2,03
DR00033U	135°	185																	2,26
DR00038U	180°	216																	2,52
DR00062U	120°	229	102	93	M5x8	80	30	17	20	32	24	1/8"	42	50	70	M6	M8	F05 + F07	3,29
DR00063U	135°	247																	3,82
DR00068U	180°	291																	4,28
DR00102U	120°	264	115	106	M5x8	80	30	17	20	32	24	1/8"	42	50	70	M6	M8	F05 + F07	4,55
DR00108U	180°	335																	5,93
DR00152U	120°	292																	6,31
DR00153U	135°	316	127	118,5	M5x8	80	30	17	20	32	24	1/4"	42	70	102	M8	M10	F07 + F10	7,05
DR00158U	180°	372																	7,75
DR00222U	120°	345																	10,1
DR00223U	135°	374	145	136	M5x8	80	30	27	30	32	24	1/4"	58	70	102	M8	M10	F07 + F10	11,4
DR00228U	180°	443																	12,6
DR00302U	120°	377																	12,1
DR00303U	135°	408	157	146,5	M5x8	80	30	27	30	32	24	1/4"	58	70	102	M8	M10	F07 + F10	13,6
DR00308U	180°	483																	15,2
DR00602U	120°	478																	23,8
DR00603U	135°	517	196	181	M5x8	80	30	27	30	32	24	1/4"	67,5	102	125	M10	M12	F10 + F12	26,7
DR00608U	180°	611																	29,1
DR01202U	120°	594																	43,5
DR01203U	135°	641	245	221,5	M5x8	130	30	36	50	32	24	1/4"	80	140	-	M16	-	F14	48,2
DR01208U	180°	754																	52,6
DR02002U	120°	/																	298,5
DR02008U	180°	867	106																
DR03002U	120°	/	330	330	M6x10	130	30	36	50	45	40	1/2"	115	165	-	M20	-	F16	
DR03008U	180°	1023																	127
DR04002U	120°	/																	/
DR04008U	180°	/	/																

Dimensions in mm; *other connections available

Specification:

Max. supply pressure: 8 bar
Operating pressure: 2,5 - 8 bar
other dimensions: see standard data sheet
Material: see data sheet 120°-135°-180° actuators

Torque: With the same operating pressure the torque is equivalent to the standard actuator. See data sheet of standard actuator.
Working Medium: refer to AIR TORQUE manual instruction.



Design: DOUBLE ACTING

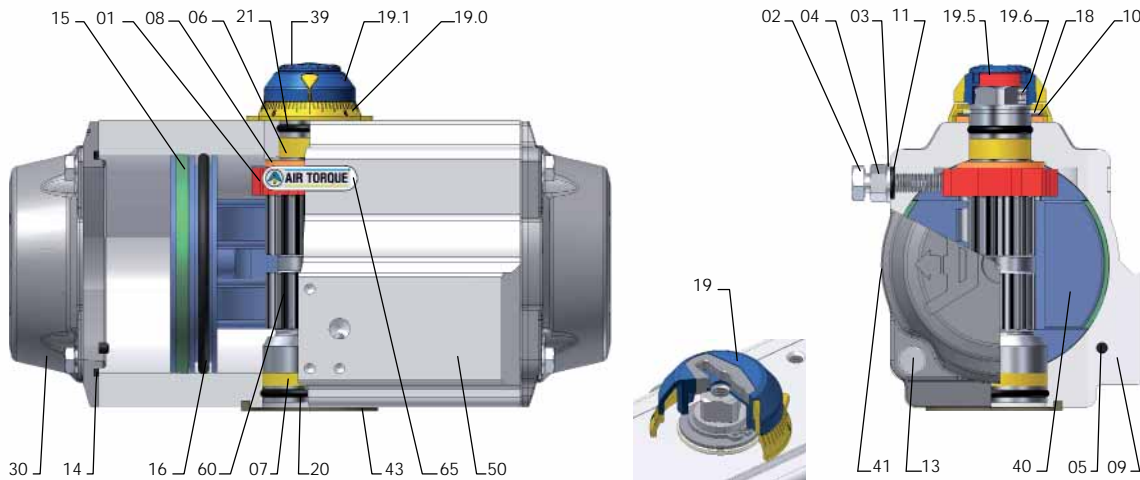

Part No.	Spare Parts	Quantity / Note	Description	Standard Material (A) (B)
01		1	Octi-Cam (Stop arrangement)	Carbon Steel, zinc coated
02		2	Stop Cap Screw	Stainless Steel
03		2	Washer	Stainless Steel
04		2	Nut (Stop screw)	Stainless Steel
05	○	2	Bearing (Piston back)	PA46
06	○	1	Bearing (Pinion top)	High-grade polymers
07	○	1	Bearing (Pinion bottom)	High-grade polymers
08	○	2	3 pcs. for model DR00600U Thrust Bearing (Pinion)	PA46
09	○ □	2	Plug	Silicone
10		1	Thrust Washer (Pinion)	Stainless Steel
11	○ □	2	O-Ring (Stop screw)	M-NBR
13		8	Cap Screw (End cap)	Edelstahl
14	○ □	2	O-Ring (End cap)	M-NBR
15	○	2	Bearing (Piston head)	POM
16	○ □	2	O-Ring (Piston)	M-NBR
18		1	Spring Clip (Pinion)	Spring Steel, ENP
19		1	for types DR00015U - 00030U Position Indicator	PA66+GF+(CB)
19.0		1	Graduated Ring	PA66+GF+CB
19.1		1	for types DR00060U - 04000U Position Indicator	PA66+GF+(CB)
19.5		1	Top Adaptor	Extruded Aluminium alloy, anodized
19.6		2	Hex. Socket Screw (Top Adaptor)	Stainless Steel
20	○ □	1	O-Ring (Pinion bottom)	M-NBR
21	○ □	1	O-Ring (Pinion top)	M-NBR
30		2	End Cap	Pressure Die Cast Aluminium alloy, anod. a. coated
39		1	Cap Screw (Indicator)	PA66+GF+CB
40		2	Piston	Pressure Die Cast Aluminium alloy, anodized
41		1	Identification Label	Polyester-Silver
43		1	Spigot (only on request)	Extruded Aluminium alloy, anodized
50		1	Body	Extruded Aluminium alloy, coated
60		1	Drive Shaft	Steel, ENP
60.1		1	only for protection „E“ a. „EC“ Integral Drive Shaft	Stainless Steel, ENP
65		1	Plastic Insert	Modified PA66

○ included in spare part kit

□ included in O-Ring spare part kit

Note: (A) For detail of material end coating specifications refer to the catalogue.
(B) For different soft parts material depending on operation temperature range refer to the catalogue.



EDITION 2010
3-Position Actuators
Description

General Information:

Air Torque 3 position pneumatic actuators 90° provide an operation of 0° - 45° - 90° or 0° - 90° - 180° for 180° actuator rotation. The intermediate position is achieved by an external mechanical stop with 2 auxiliary pistons (for spring return actuators it may be only one auxiliary piston). This intermediate stop position is adjustable, for example 5°, 20°, 30°, 50°, 75° etc. The intermediate position is easily achieved by adjusting the external nuts located outside the two end-caps. Both type, double acting and spring return, are available.

Field of application: For dosing, for exact filling and for any kind of services where on 90° rotation an intermediate stop position is desired.



To control and operate the 3-Position actuators a system of solenoid valves and a sequence of air supply is required:

Operation 3-Position Actuators ED 2010

double acting

Rotation 90°

- Type: 3PD DR ... 90°

Rotation 180°

- Type: 3PD DR ...180°

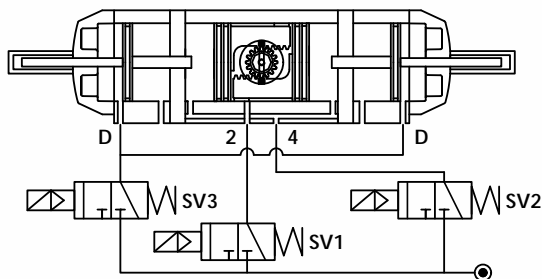

Rotation 90°	Rotation 180°	Solenoid Valve energized	Pressurized Port
0° -> 90°	0° -> 180°	SV1	2
90° -> 0°	180° -> 0°	SV2	4
0° -> X°	0° -> Y°	first SV3 + after SV1	D + 2
X° -> 90°	Y° -> 180°	SV1	2
90° -> X°	180° -> Y°	SV3	D
X° -> 0°	Y° -> 0°	SV2	4

X: Intermediate position, 0° to 90°

Y: Intermediate position, 90° to 180°

- Note:**
1. As an alternative, the solenoid valve SV3 can be replaced by 2 solenoid valves directly applied to NAMUR connections on the 2 auxiliary bodies.
 2. As an alternative, the solenoid valves SV1 and SV2 can be replaced by one 5/3 bistable solenoid valve directly applied to NAMUR connections on the central body.

3-Position Actuators ED 2010, Rotation 90°

Spring return - type: 3PD SC ...

Spring return - type: 3P SC ...

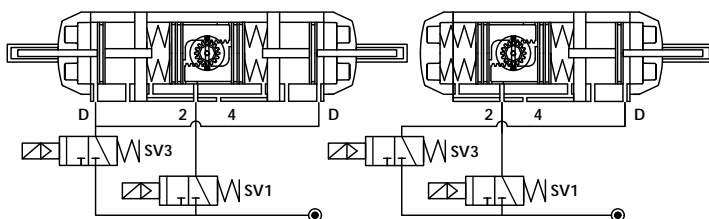

Rotation	Solenoid Valve energized	Pressurized Port
0° -> 90°	SV1	2
90° -> 0°	air failure at port 2 - apring action	
0° -> X°	first SV3 + after SV1	D + 2
X° -> 90°	SV1	2
*90° -> X°	first SV1 + after SV3	2 + D
X° -> 0°	Abluft an 2 - Federwirkend	

***Note:** This function is achievable **only** with 3-Position Spring Return actuators with 2 auxiliary pistons (external mechanical stop).

Note: As an alternative for **3PD**, the solenoid valve SV3 can be replaced by 2 solenoid valves directly applied to NAMUR connections on the 2 auxiliary bodies.



EDITION 2010
3-Position Actuators
Description



AIR TORQUE
PNEUMATISCHE STELLANTRIEBE

3PD for model: Spring return and double acting 90°, plus double acting 180°

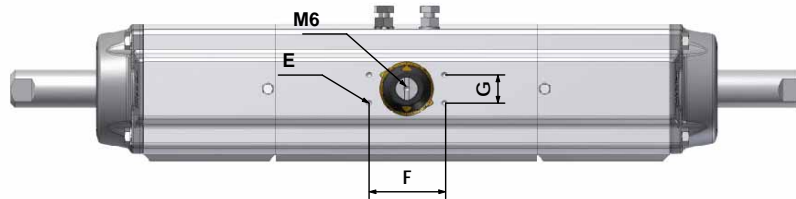
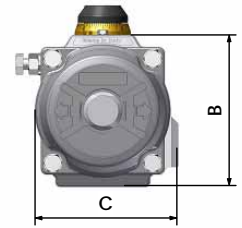
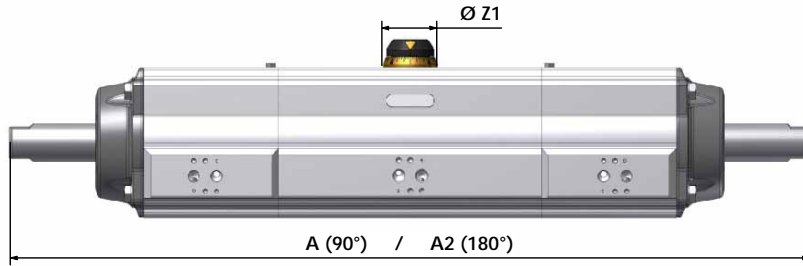

AIR CONNECTION VDI/VDE 3845

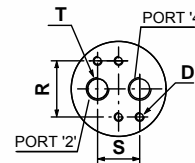

3P only for model: Spring return 90°

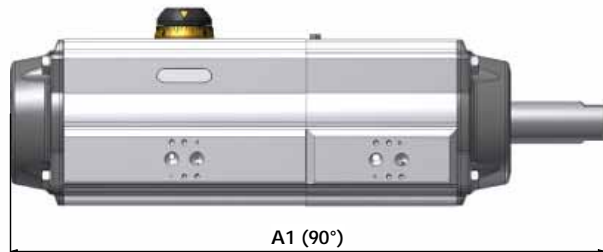

BOTTOM VIEW ISO 5211

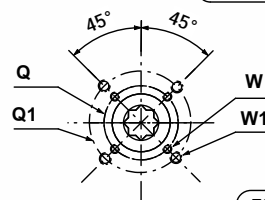

DOUBLE SQUARE



PARALLEL SINGLE SQUARE



DIAGONAL SINGLE SQUARE



TOP SQUARE DRIVE SHAFT

ONLY FOR MODEL 3P/3PD
DR/SC00030U 90°
3P/3PD DR/SC00030U 180°

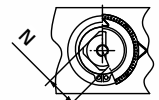
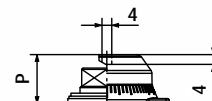

FOR MODEL
3P/3PD DR/SC 00060U - 03000U 90°
3P/3PD DR/SC 00060U - 03000U 180°

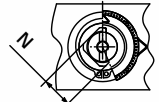
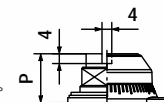

Actuator** Type 3PD/3P	A 90°	A1 90°	A2 180°	B	C	D	E	F	G	N	P	R	S	Z1	T-ISO 228	ISO* Flange	Q	Q1	W	W1
DR/SC00030	392	273	454	85	84,5	M5x8	M5x8	80	30	11	20	32	24	42	1/8"	F05+F07	50	70	M6	M8
DR/SC00060	481	342	568	102	93	M5x8	M5x8	80	30	17	20	32	24	42	1/8"	F05+F07	50	70	M6	M8
DR/SC00100	578	409	672	115	106	M5x8	M5x8	80	30	17	20	32	24	42	1/4"	F05+F07	50	70	M6	M8
DR/SC00150	617	438	730	127	118,5	M5x8	M5x8	80	30	17	20	32	24	42	1/4"	F07+F10	70	102	M8	M10
DR/SC00300	798	565	948	157	146,5	M5x8	M5x8	80	30	27	30	32	24	58	1/4"	F07+F10	70	102	M8	M10
DR/SC00600	989	705	1177	196	181	M5x8	M5x8	80	30	27	30	32	24	67,5	1/4"	F10+F12	102	125	M10	M12
DR/SC01200	1290	909	1514	245	221,5	M5x8	M5x8	130	30	36	50	32	24	80	1/4"	F14	140	/	M16	/
DR/SC03000	1725	1218	2030	330	330	M6x10	M5x8	130	30	36	50	45	40	115	1/2"	F16	165	/	M20	/

*Note: Other connections available; ** Further models on request; Dimensions in mm

Specification:

Max. supply pressure: 8 bar
Operating pressure: 2,5 - 8 bar
Other dimensions: see data sheet
Material: see data sheet of 3P actuator

Output torque:

With the same operation pressure and/or the same number of springs, the torque is equivalent to the standard actuator.

Operating media:

See data sheet of standard actuator.

Temperature:

-20°C bis +80°C

Air Torque GmbH

Im Katzentach 16-18 · DE - 76275 Ettlingen
Tel.: +49 (0)7243 59 34-0 · Fax : +49 (0)7243 59 34-34
info@airtorque.de · www.airtorque.de

Modifications reserved. Date 10.2011.
No guarantee for accuracy.
Older data sheets are invalid.

Dosing
0604e



Technical Data:

DR/SC00030U - DR/SC03000U

Adjustable operating time for 90° stroke

Air supply 5,5 bar (80 Psi)		
Actuator Type	Min. approx. (Sek.) **	Max. (Sek.) **
HCD DR/SC00030U	2,5	> 20
HCD DR/SC00060U	3	> 20
HCD DR/SC00100U	3,5	> 20
HCD DR/SC00150U	4	> 20
HCD DR/SC00300U	6	> 20
HCD DR/SC00600U	8	> 30
HCD DR/SC01200U	11	> 30
HCD DR/SC03000U	15	> 30

** Actuator operating time without resistance load

The operating times depend on:

- Air supply pressure
- Valve torque
- Adjustment of the speed flow control

Function:

Flow Capacity Required:

For type HCD DR/SC00030U - 00300U
0 to 300 NL/min at 5,5 bar (80 psi)

For type HCD DR/SC00600U - 03000U
0 to 1500 NL/min at 5,5 bar (80 psi)

Solenoid valve and speed flow control are not a part of the actuator.

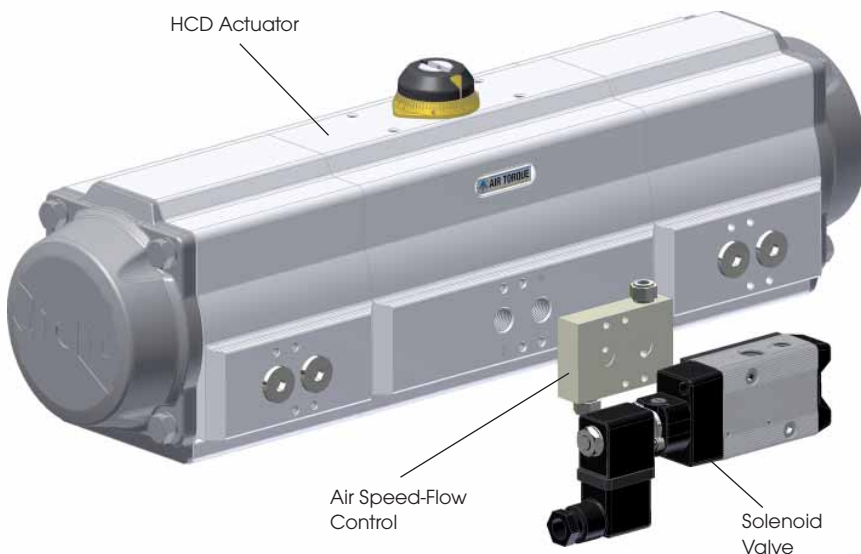

Type HCD SC00030U => HCD SC03000U: Pneumatic / Hydraulic Circuit Scheme

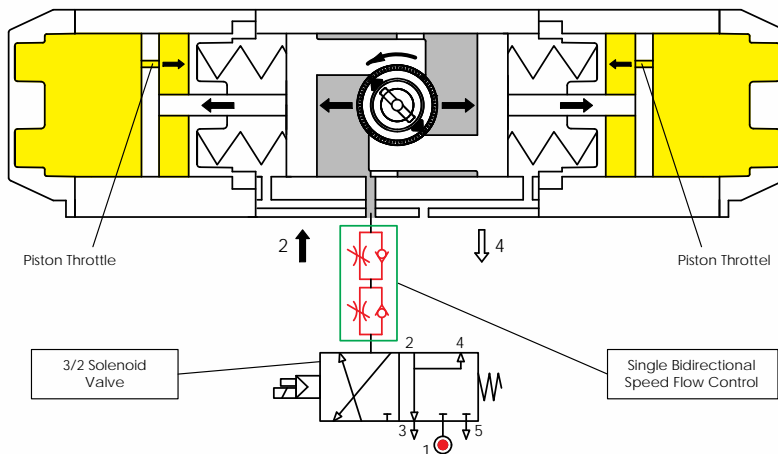

Type HCD DR00030U => HCD DR03000U: Pneumatic / Hydraulic Circuit Scheme

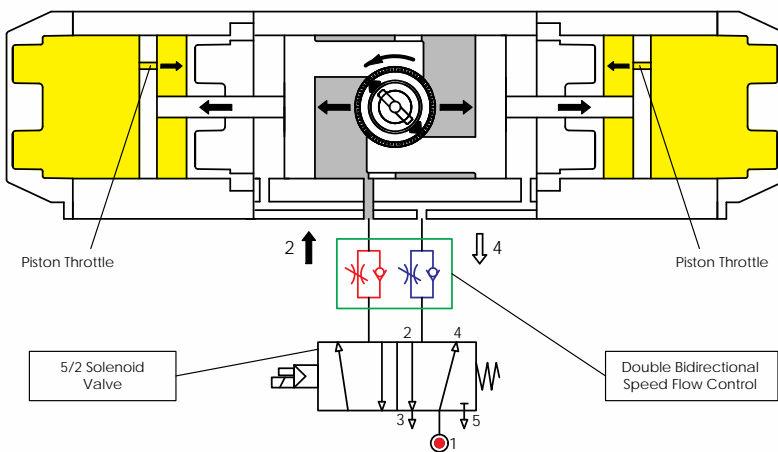



Dimensions and Technical Data:

DR/SC00030U - DR/SC03000U

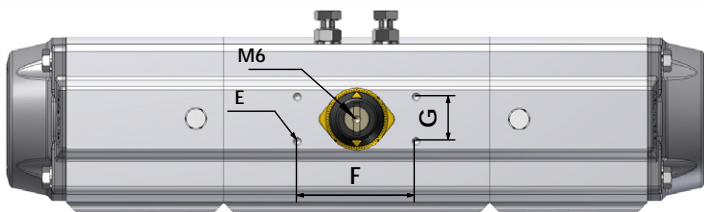
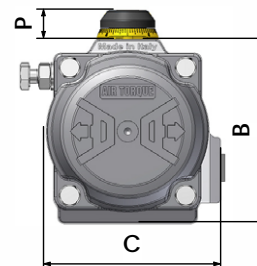
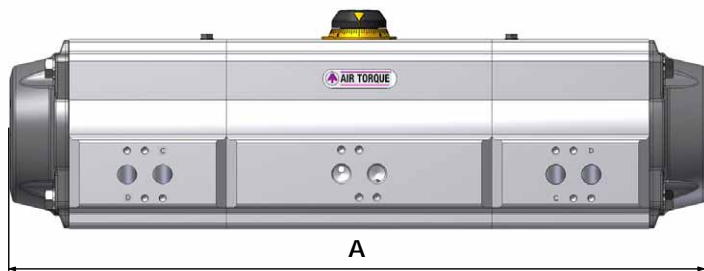

Top Square Drive Shaft

Bottom View ISO 5211

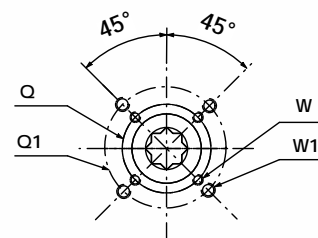

Only for type
HCD DR/SC00030U

Only for type
HCD DR/SC00060U - 03000U

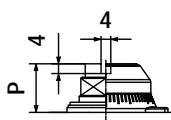
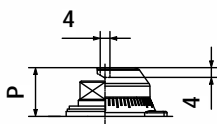

Air Connection VDI/VDE 3845

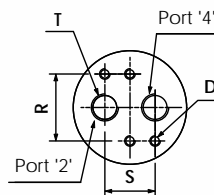

Single Square
PARALLEL



Single Square
DIAGONAL



Square
DOUBLE

**Actuator Type	A	B	C	D	E	F	G	N	P	R	S	Z1	T - ISO 228	ISO* Flange	Q	Q1	W	W1	ca. Weight in KG	
																			DR**	SC**
HCD DR/SC00030U	283,5	85	84,5	M5x8	M5x8	80	30	11	20	32	24	42	1/8"	F05 + F07	50	70	M6	M8	3,1	3,2
HCD DR/SC00060U	369,5	102	93	M5x8	M5x8	80	30	17	20	32	24	42	1/8"	F05 + F07	50	70	M6	M8	5,7	6,1
HCD DR/SC00100U	432,5	115	106	M5x8	M5x8	80	30	17	20	32	24	42	1/4"	F05 + F07	50	70	M6	M8	6,5	7,5
HCD DR/SC00150U	471	127	118,5	M5x8	M5x8	80	30	17	20	32	24	42	1/4"	F07 + F10	70	102	M8	M10	11	12
HCD DR/SC00300U	614,5	157	146,5	M5x8	M5x8	80	30	27	30	32	24	58	1/4"	F07 + F10	70	102	M8	M10	21,5	23
HCD DR/SC00600U	760,5	196	181	M5x8	M5x8	80	30	27	30	32	24	67,5	1/4"	F10 + F12	102	125	M10	M12	45	49,5
HCD DR/SC01200U	964	245	221,5	M5x8	M5x8	130	30	36	50	32	24	80	1/4"	F14	140	-	M16	-	75	84
HCD DR/SC03000U	1254	330	330	M6x10	M5x8	130	30	36	50	45	40	115	1/2"	F16	165	-	M20	-	160	180

* Note: Other connections available. Dimensions in mm.

** DR = double acting / SC = spring return with 6 springs per side

Specification:

Max. supply pressure: 6,5 bar (95 psi)
Operating pressure: 2,5 - 6,5 bar
Hydraulic fluid biodegradable.

Other dimensions: see data sheet of standard actuator
Operating media: see AIR TORQUE manual instruction
Temperature: -20°C to +80°C

Important Note: For a correct operation of this actuator we suggest a torque sizing based on a safety factor of at least 30%.



EDITION 2010
Actuator (180°) with
Fail Safety Position



AIR TORQUE

PNEUMATISCHE STELLANTRIEBE

General Information:

The 180° spring return actuators with 90° fail safety position are used for 0°-90°-180° operations where in case of air failure the actuator has to return to the 90° position.

At both ends of the actuator a spring set is mounted and the springs can be compressed in two directions: toward end caps or inward. Pressure supplied at port 4 forces the pistons toward actuator end caps and rotate the actuator drive shaft from 0° or 180° compressing the springs, while pressure supplied at port 2 forces the pistons inward and rotate the actuator drive shaft from 90° to 0°.

From fully close position (0°) or fully open position (180°) the fail safe operation is achieved in case of air or electrical failure by extension of the compressed springs. They push the pistons to rotate the actuator drive shaft from 0° or 180° position to 90° position.



Operation: (For Standard Assembly ST)

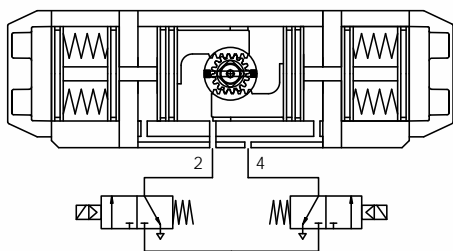

2 x 3/2 way solenoid valve
1 x 5/3 way solenoid valve

A system of solenoid valves that control the sequence of air supplies is required in order to operate correctly the 180° spring return actuator with 90° Fail Safety position.

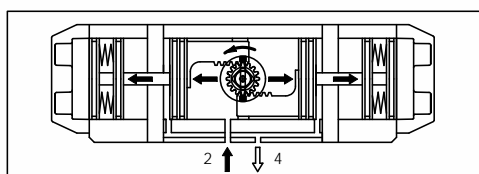

from 90° to 180°:

When compressed air is supplied at the port 2, air forces the pistons toward actuator end caps and compresses the springs from the center to the outside ends. A counterclockwise rotation is obtained.

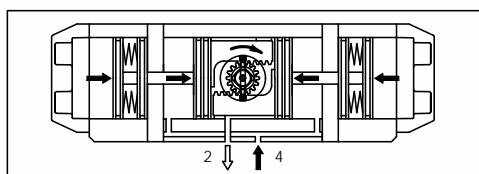

from 90° to 0°:

When compressed air is supplied at the port 4, air forces the pistons inward and compresses the springs from their outside ends to the center. A clockwise rotation is obtained.

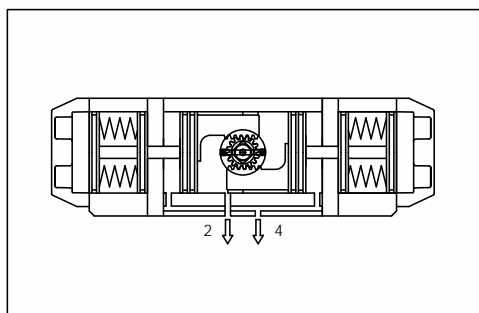

Air fail operation:

From 180° position: the air pressure loss (air or electric failure) at port 2 allows the springs to force the pistons inward (until 90° position) with the exhaust air exiting at port 2, a clockwise rotation is achieved.

From 0° position: the air pressure loss (air or electric failure) at port 4 allows the springs to force the pistons toward the actuator (until 90° position) with the exhaust air exiting at port 4, a counterclockwise rotation is achieved.



EDITION 2010
Actuator (180°) with
Fail Safety Position



AIR TORQUE

PNEUMATISCHE STELLANTRIEBE

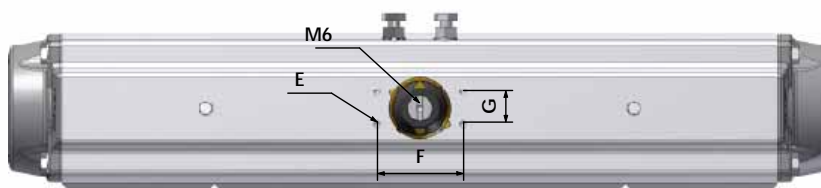
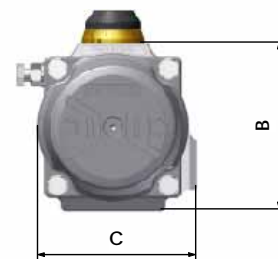
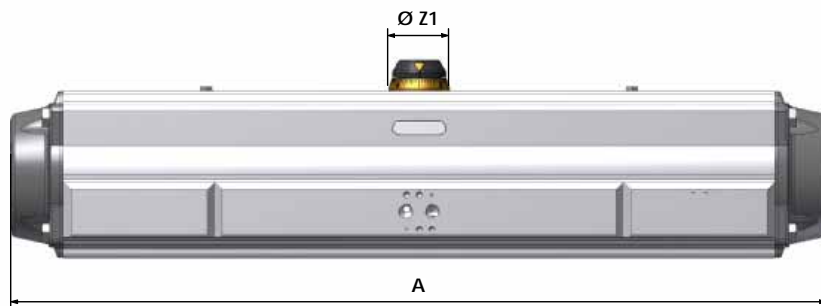

Air Connection VDI/VDE 3845

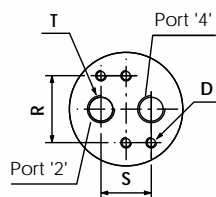

Bottom View ISO 5211

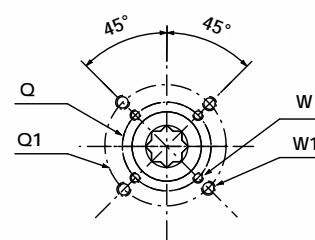

Top Square Drive Shaft

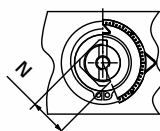
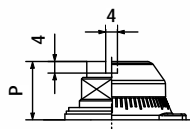

For type
FM SC00158
->
FM SC01208

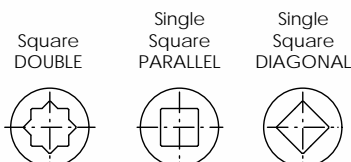

Actuator** Type	A	B	C	D	E	F	G	N	P	R	S	Z1	T - ISO 228	ISO* Flange	Q	Q1	W	W1
FM SC00158U	581	127	118,5	M5x8	M5x8	80	30	17	20	32	24	42	1/4"	F07 + F10	70	102	M8	M10
FM SC00308U	749	157	146,5	M5x8	M5x8	80	30	27	30	32	24	58	1/4"	F07 + F10	70	102	M8	M10
FM SC00608U	951	196	181	M5x8	M5x8	80	30	27	30	32	24	67,5	1/4"	F10 + F12	102	125	M10	M12
FM SC01208U	1180	245	221,5	M5x8	M5x8	130	30	36	50	32	24	80	1/4"	F14	140	/	M16	/

*Note: Other connections on request; ** Other models on request; Dimensions in mm

Specification:

Max. supply pressure: 8 bar
Operating pressure: 2,5 - 8 bar
Other dimensions: see std. data sheet
Material: see data sheet Fail-Mid

Output torque: With the same operating pressure and/or the same number of springs, the torque is equivalent to the standard actuator. See data sheet of standard actuator.
Operating media: Refer to AIR TORQUE manual instruction.
Temperature: -20°C to +80°C



EDITION 2010 Spring Return Actuators 180° Rotation



AIR TORQUE
PNEUMATISCHE STELLANTRIEBE

General Information:

AIR TORQUE Single acting 180° actuators „EDITION 2010“ provide a rotation of 180° and in case of air or electric failure the closing is provided by the spring return operation.

The external travel stop adjustments are available as a standard in fully OPEN position (180°) and in fully CLOSE position (0°), and they are easily and precisely adjustable by +/-5° in both directions.

Fields of application: 3 or 4 way valves, special valves for sample taking and any application where a 180° rotation is required.



Specification:

Max. supply pressure: 8 bar
 Operating pressure: 2.5 - 8 bar
 Temperature: -20°C to +80°C
 Other Dimensions: see standard data sheet
 Operating media: see AIR TORQUE manual instruction

Spring Return Actuator Output Torque (Nm)

Type	Spring Set	2,5 bar		3 bar		3,5 bar		4 bar		4,2 bar		4,5 bar		5 bar		5,5 bar		6 bar		7 bar		8 bar		Spring	
		0°	180°	0°	180°	0°	180°	0°	180°	0°	180°	0°	180°	0°	180°	0°	180°	0°	180°	0°	180°	0°	180°	0°	180°
SC00018-	1	4	1,9	6,0	3,6	7,7	5,3	9,3	6,9	10	7,6	11,0	8,6	12,7	10,2	14,3	11,9							6,4	4,0
	2					6,3	3	8,0	5	8,7	5,5	9,7	6,4	11,3	8,1	13,0	9,8	14,7	11,4					8,5	5,3
	3											8,4	4,3	10,0	6,0	11,7	7,6	13,3	9,3	16,7	12,6	20,0	16	10,6	6,6
	4															10,4	6	12,0	7,2	15,3	10,5	18,7	13,8	12,8	7,9
SC00038-	3	8	4,5	10,9	7,5	13,9	10,4	16,8	13,3	18	14,5	19,7	16,3	22,7	19,2	25,6	22,1							10,1	6,7
	4					11,6	7	14,6	10	15,7	11,1	17,5	12,9	20,4	15,8	23,4	18,7	26,3	21,7	32,2	27,5			13,5	8,9
	5											15,3	9,5	18,2	12,4	21,1	15,4	24,1	18,3	29,9	24,2	35,8	30	16,9	11,1
	6														18,9	12	21,9	14,9	27,7	20,8	33,6	26,7	20,2	13,3	
SC00068-	3	15,8	8,3	21,6	14,1	27,5	19,9	33,3	25,8	35,6	28,1	39,1	31,6	44,9	37,4	50,7	43,2							21	13,3
	4					23	13	28,8	18,8	31,2	21,2	34,7	24,7	40,5	30,5	46,3	36,3	52,1	42,1	63,7	53,7			27,7	17,7
	5											30,2	17,7	36,1	23,6	41,9	29,4	47,7	35,2	59,3	46,8	71	58,5	34,6	22,1
	6														37,5	22,4	43,3	28,3	54,9	39,9	66,5	51,5	41,5	26,5	
SC00108-	3	23,8	11,1	32,9	20,3	42,1	29,4	51,2	38,6	54,9	42,2	60,4	47,7	69,5	56,9	78,7	66							34,7	22
	4					34,7	17,9	43,9	27	47,5	30,7	53	36,2	62,2	45,3	71,3	54,5	80,5	63,6	98,8	81,9			46,2	29,3
	5											45,7	24,6	54,8	33,8	64	42,9	73,1	52,1	91,5	70,4	110	88,7	57,8	36,7
	6														56,7	31,4	65,8	40,5	84,1	58,8	102	77,1	69,3	44	
SC00158-	3	36,1	19,2	49,4	32,5	62,7	45,8	76	59,1	81,3	64,4	89,3	72,4	103	85,7	116	99							47,3	30,4
	4					52,5	30	65,8	43,3	71,1	48,7	79,1	56,6	92,4	69,9	106	83,2	119	96,5	146	123			63	40,5
	5											69	40,9	82,3	54,2	95,6	67,5	109	80,8	135	107	162	134	78,8	50,7
	6														85,4	51,7	99	65	125	92	152	118	94,5	60,8	
SC00228-	3	58,3	28,8	79,7	50,3	101	71,8	123	93,3	131	102	144	115	166	136	187	158							78,6	49,2
	4					84,8	45,6	106	67,1	115	75,7	128	88,6	149	110	171	132	192	153	235	196			105	65,6
	5											111	62,4	133	83,9	154	105	176	127	219	170	262	213	131	82
	6														138	79,2	159	101	202	144	245	187	157	98,4	
SC00308-	3	75,5	39,6	103	67,3	131	95,0	159	123	170	134	186	150	214	178	242	206							98,9	63
	4					110	62	138	89,7	149	101	165	117	193	145	221	173	248	201	304	256			132	84
	5											144	84,5	172	112	200	140	227	168	283	223	338	278	165	105
	6														179	107	206	135	262	190	317	245	198	126	
SC00608-	3	149	84	206	141	262	198	319	255	342	277	376	311	433	368	489	425							199	135
	4					218	131	274	188	297	211	331	245	388	302	444	358	501	415	615	528			266	180
	5											286	178	343	235	400	292	456	349	570	462	683	575	332	224
	6														355	225	411	282	525	396	638	509	399	269	
SC01208-	3	277	154	383	260	489	367	596	473	638	515	702	579	808	686	915	792							378	255
	4					404	241	511	347	553	390	617	453	723	560	830	666	936	772	1149	985			504	340
	5											532	327	638	434	745	540	851	646	1064	859	1277	1072	630	425
	6														660	414	766	520	979	733	1192	946	756	510	
SC02008-	3	461	268	640	447	818	625	997	804	1068	876	1176	983	1354	1162	1533	1340							625	433
	4					674	417	853	596	924	667	1032	774	1210	953	1389	1132	1568	1310	1925	1668			834	577
	5											887	566	1066	745	1245	923	1423	1102	1781	1459	2138	1817	1042	721
	6														1101	715	1279	894	1637	1251	1994	1608	1251	865	



SC00018 -> SC000308

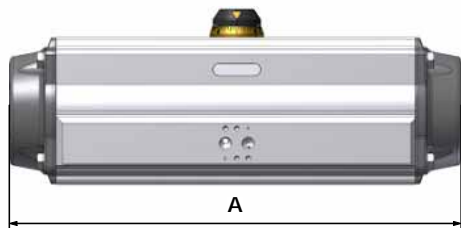

SC00608 -> SC02008

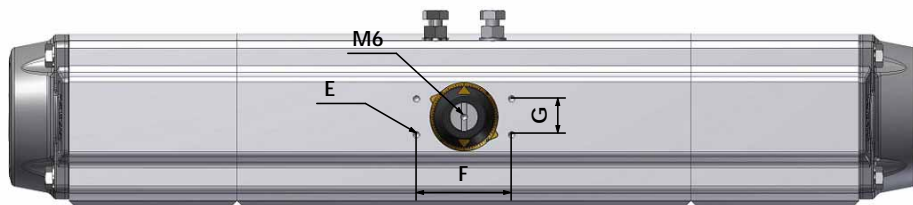
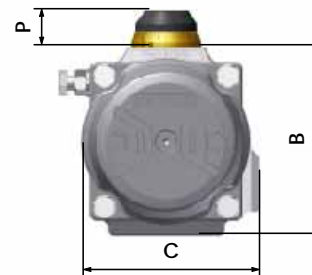
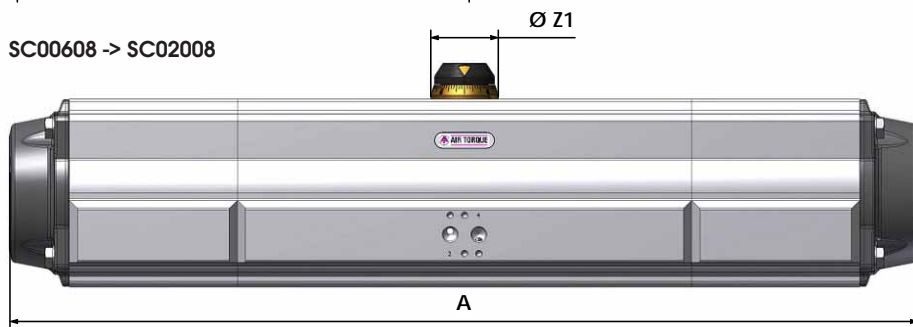

Air Connection VDI/VDE 3845

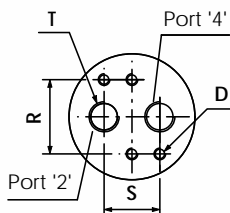

Single Square
PARALLEL



Single Square
DIAGONAL



Square
DOUBLE



Bottom View ISO 5211

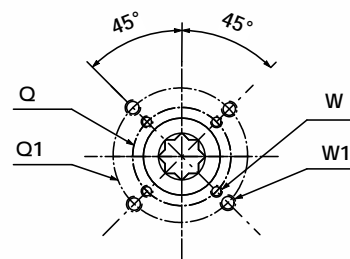

Actuator** Type	A	B	C	D	E	F	G	N	P***	R	S	Z1	T - ISO 228	ISO* Flange	Q	Q1	W	W1
SC00018	258	69	71	M5x8	M5x8	80	30	11	20	32	24	42	1/8"	F04	42	-	M5	-
SC00038	291	85	84,5	M5x8	M5x8	80	30	11	20	32	24	42	1/8"	F05 - F07	50	70	M6	M8
SC00068	386	102	93	M5x8	M5x8	80	30	17	20	32	24	42	1/8"	F05 - F07	50	70	M6	M8
SC00108	449	115	106	M5x8	M5x8	80	30	17	20	32	24	42	1/4"	F05 - F07	50	70	M6	M8
SC00158	493	127	118,5	M5x8	M5x8	80	30	17	20	32	24	42	1/4"	F07 - F10	70	102	M8	M10
SC00228	576	145	136	M5x8	M5x8	80	30	27	20	32	24	58	1/4"	F07 - F10	70	102	M8	M10
SC00308	631	157	146,5	M5x8	M5x8	80	30	27	30	32	24	58	1/4"	F07 - F10	70	102	M8	M10
SC00608	802	196	181	M5x8	M5x8	80	30	27	30	32	24	67,5	1/4"	F10 - F12	102	125	M10	M12
SC01208	1006	245	221,5	M5x8	M5x8	130	30	36	50	32	24	80	1/4"	F14	140	-	M16	-
SC02008	1142	298,5	262	M6x10	M5x8	130	30	36	50	45	40	115	3/8"	F16	165	-	M20	-

*Note: Other connections available; **other models possible; ***For top square drive shaft see data sheet; Dimensions in mm



Design: **Single Acting**

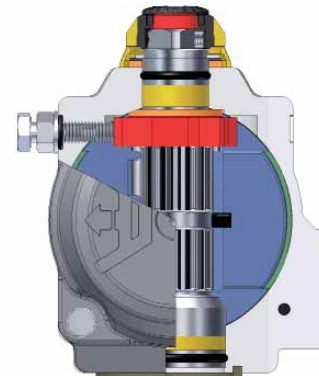
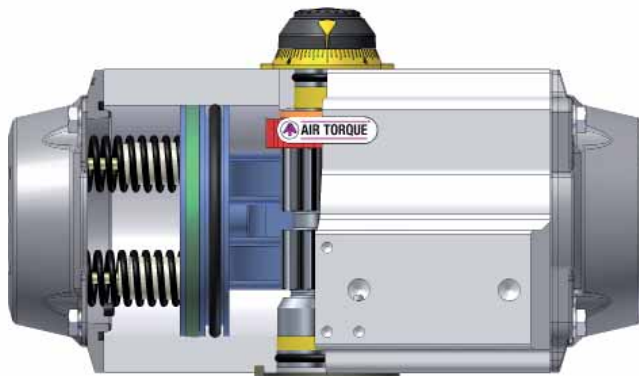

Special Body

Technical Data and Operating Times:

Actuators Type FA	Air Connection Size Port 2	Extra Air Connection	Air Bore (mm)			* min. Operating Time (sec.)	
			Port 2	Port 4	Port EAC	Spring Return	
						OPEN	CLOSE
FA SC00100U	G 1/8"-ISO228	-	ø6	ø4,5	-	0,3	0,25
FA SC00150U	G 1/4"-ISO228	-	ø7	ø5	-	0,4	0,35
FA SC00220U	G 1/4"-ISO228	G1/4"-ISO228	ø9	-	ø8	0,15	0,20
FA SC00300U	G 1/4"-ISO228	G1/4"-ISO228	ø9	-	ø8	0,20	0,25
FA SC00450U	G 1/4"-ISO228	G1/4"-ISO228	ø10	-	ø10	0,22	0,28
FA SC00600U	G 1/4"-ISO228	G1/4"-ISO228	ø10	-	ø10	0,28	0,35
FA SC00900U	G 3/8"-ISO228	G3/8"-ISO228	ø12	-	ø12	0,32	0,40
FA SC01200U	G 3/8"-ISO228	G3/8"-ISO228	ø12	-	ø12	0,38	0,45
FA SC02000U	G 1/2"-ISO228	G1/2"-ISO228	ø13	-	ø13	0,46	0,55
FA SC03000U	G 1/2"-ISO228	G1/2"-ISO228	ø15	-	ø15	0,52	0,60
FA SC04000U	G 3/4"-ISO228	G1/2"-ISO228	ø18	-	ø16	0,87	0,95
FA SC05000U	G 3/4"-ISO228	-	ø20	-	-	1,00	1,30

Test Condition:

* The MINIMUM Operating Time is obtained by the following test conditions:

- (1) Room Temperature, (2) Spring Return Actuator with max. number of springs, Stroke: 90°, (3) Minimum inside diameter for air supply circuit equal to air bore Port 2, (4) Medium clean air, (5) Air supply pressure: 6bar (87psi), (6) Actuator without external resistance load, (7) Supply circuit without solenoid valve.

Attention: The indicated operating times are strictly related to the above specified test conditions. The operating times on the field applications are different depending on the working conditions.

Note:

For other dimensions see catalogue or technical data sheet.

For maintenance and installation see manual instruction.

The Fast Acting actuator cycle life may result lower than for the standard actuators in relation to the field of working conditions.



Design: Single Acting

FA SC00100U - 00150U

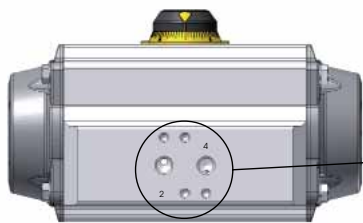

Port 2:
Air connection for
internal chamber
with special bigger
bore

Port 4:
Air connection for
external chambers

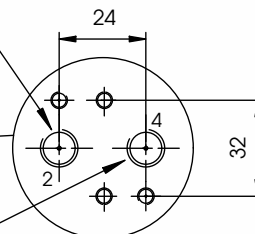

FA SC00220U - 02000U

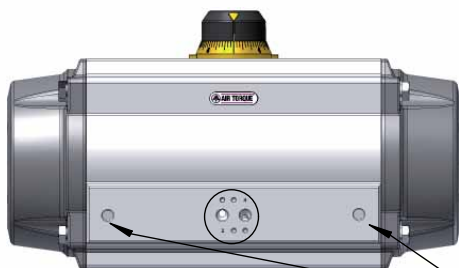

Port 2:
Air connection for
internal chamber

Port 4:
Air connection for
external chambers

Port EAC:
Extra air connections for external chambers
Exhaust air holes for SC (filter only on request)

Connection for type
FA SC00220U => 0600U

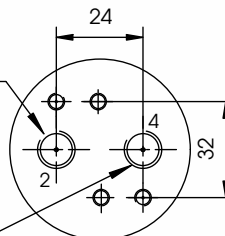

Connection for type
FA SC00900U => 02000U

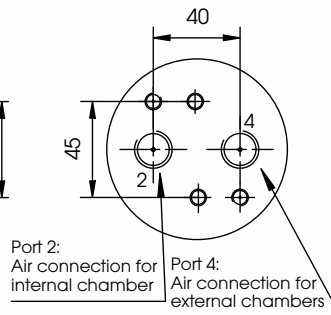

Port 2:
Air connection for
internal chamber

Port 4:
Air connection for
external chambers

FA SC03000U - 04000U

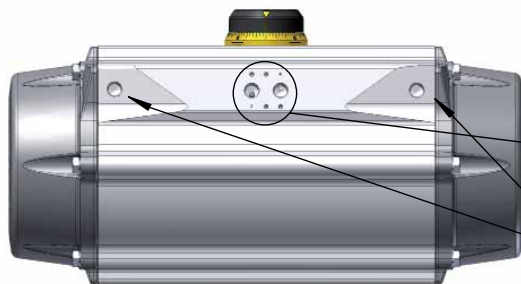

Port 2:
Air connection for
internal chamber

Port 4:
Air connection for
external chambers

Port EAC:
Extra air connections for external chambers
Exhaust air holes for SC (filter only on request)

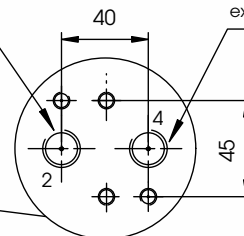

FA SC5000U

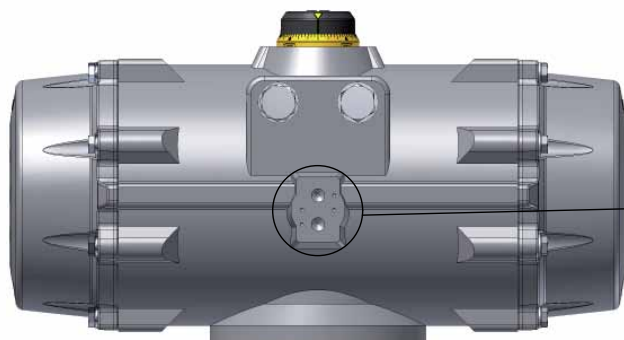

Port 4:
Air connection for
external chambers

Port 2:
Air connection for
internal chamber
with special bigger
bore

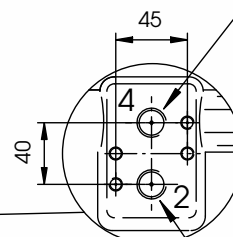



Design: Double Acting

FA DR00100U to FA DR00150U

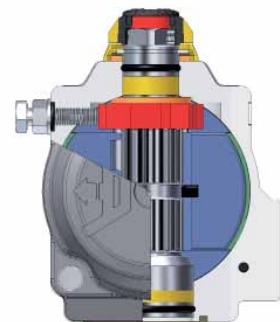
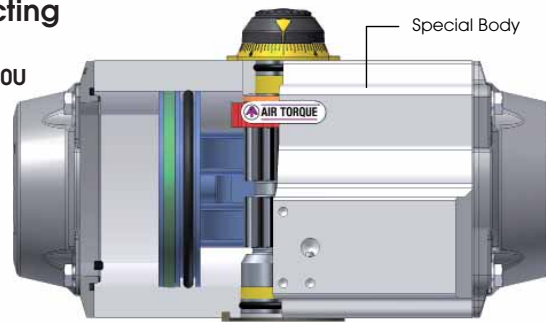

FA DR00220U to FA DR05000U

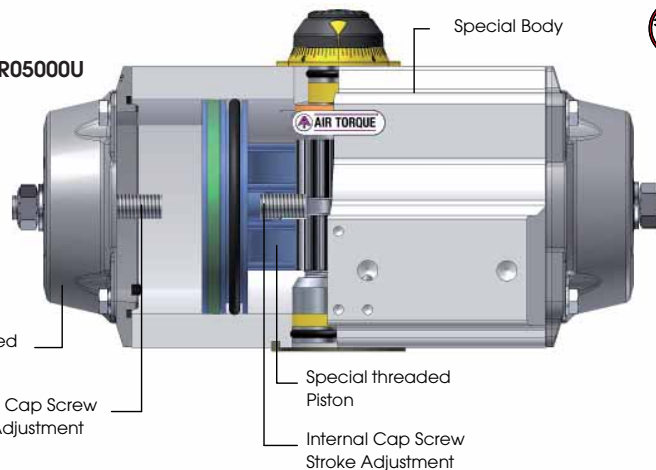

DO NOT REMOVE THE SCREW

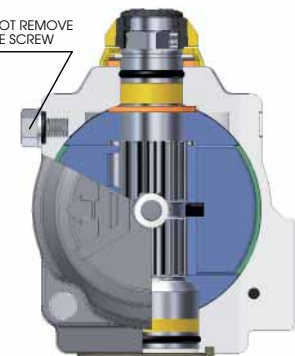

Technical Data and Operating Time:

Actuator Type FA	Air Connection Size Port 2	Air Connection Size Port 4	Extra Air Connection	Air Bore (mm)			* min. Operating Time (sec.)	
				Port 2	Port 4	Port EAC	Double Acting	
							OPEN	CLOSE
FA DR00100U	G 1/8"-ISO228	G 1/8"-ISO228	-	ø6	ø4,5	-	0,09	0,12
FA DR00150U	G 1/4"-ISO228	G 1/4"-ISO228	-	ø7	ø5	-	0,18	0,23
FA DR00220U	G 1/4"-ISO228	G 1/4"-ISO228	G 1/4"-ISO228	ø9	-	ø8	0,06	0,09
FA DR00300U	G 1/4"-ISO228	G 1/4"-ISO228	G 1/4"-ISO228	ø9	-	ø8	0,07	0,10
FA DR00450U	G 1/4"-ISO228	G 1/4"-ISO228	G 1/4"-ISO228	ø10	-	ø10	0,09	0,12
FA DR00600U	G 1/4"-ISO228	G 1/4"-ISO228	G 1/4"-ISO228	ø10	-	ø10	0,15	0,23
FA DR00900U	G 3/8"-ISO228	G 3/8"-ISO228	G 3/8"-ISO228	ø12	-	ø12	0,20	0,30
FA DR01200U	G 3/8"-ISO228	G 3/8"-ISO228	G 3/8"-ISO228	ø12	-	ø12	0,25	0,35
FA DR02000U	G 1/2"-ISO228	G 1/2"-ISO228	G 1/2"-ISO228	ø13	-	ø13	0,30	0,40
FA DR03000U	G 1/2"-ISO228	G 1/2"-ISO228	G 1/2"-ISO228	ø15	-	ø15	0,35	0,45
FR DR04000U	G 3/4"-ISO228	G 1/2"-ISO228	G 1/2"-ISO228	ø18	-	ø16	0,37	0,48
FA DR05000U	G 3/4"-ISO228	G 1/2"-ISO228	-	ø20	-	-	0,40	0,50

Test Condition:

* The MINIMUM Operating Time indicated is obtained in the following test conditions: (1) Room Temperature, (2) Double Acting Actuator, Stroke: 90°, (3) Minimum inside diameter for air supply circuit equal to air bore Port 2, (4) Medium clean air, (5) Air supply pressure: 6bar (87psi), (6) Actuator without external resistance load, (7) Supply circuit without solenoid valve.

Attention: The indicated operation times are strictly related to the above test conditions. The operating times on the field applications are different depending on the working conditions.

Note:

For other dimensions see catalogue or technical data sheet.

For maintenance and installation see manual instruction. The Fast Acting actuator cycle life may result lower than for the standard actuators in relation to the field conditions.



Design: Double Acting

FA DR00100U to FA DR00150U

Dimensions in mm

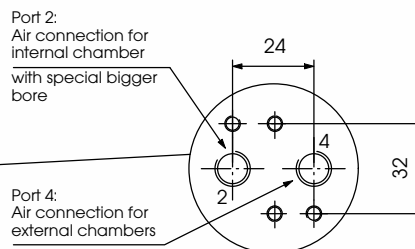
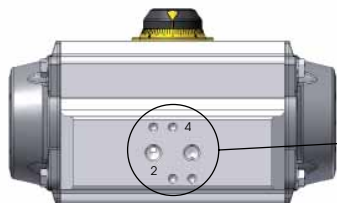

FA DR00220U to FA DR02000U

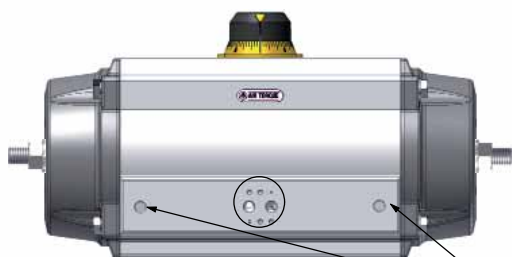

Interface connection for type
FA DR00220U to FA DR00600U

Interface connection for type
FA DR0900U to FA DR02000U

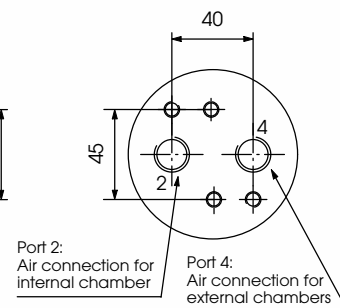
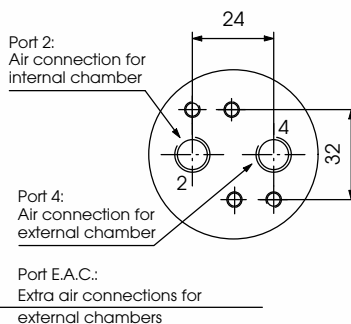

FA DR03000U bis FA DR04000U

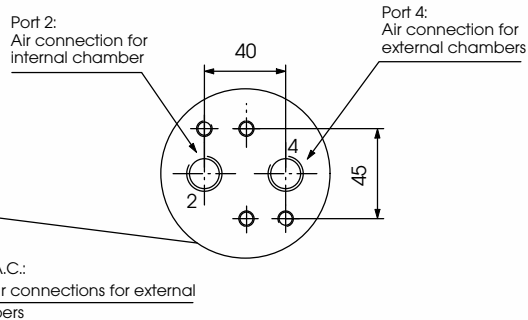
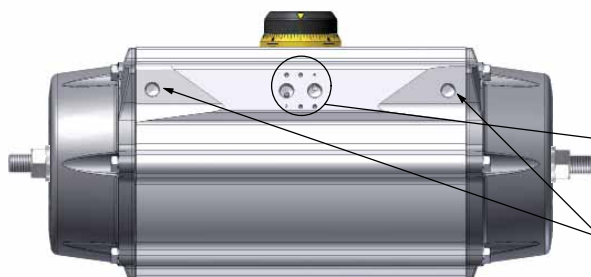

FA DR05000U

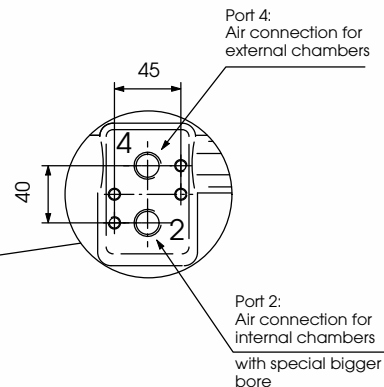
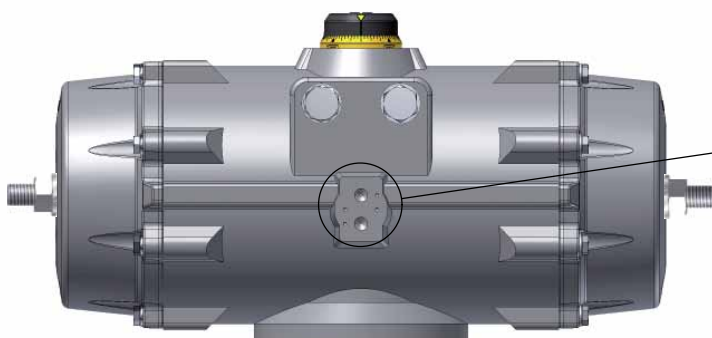



Design:

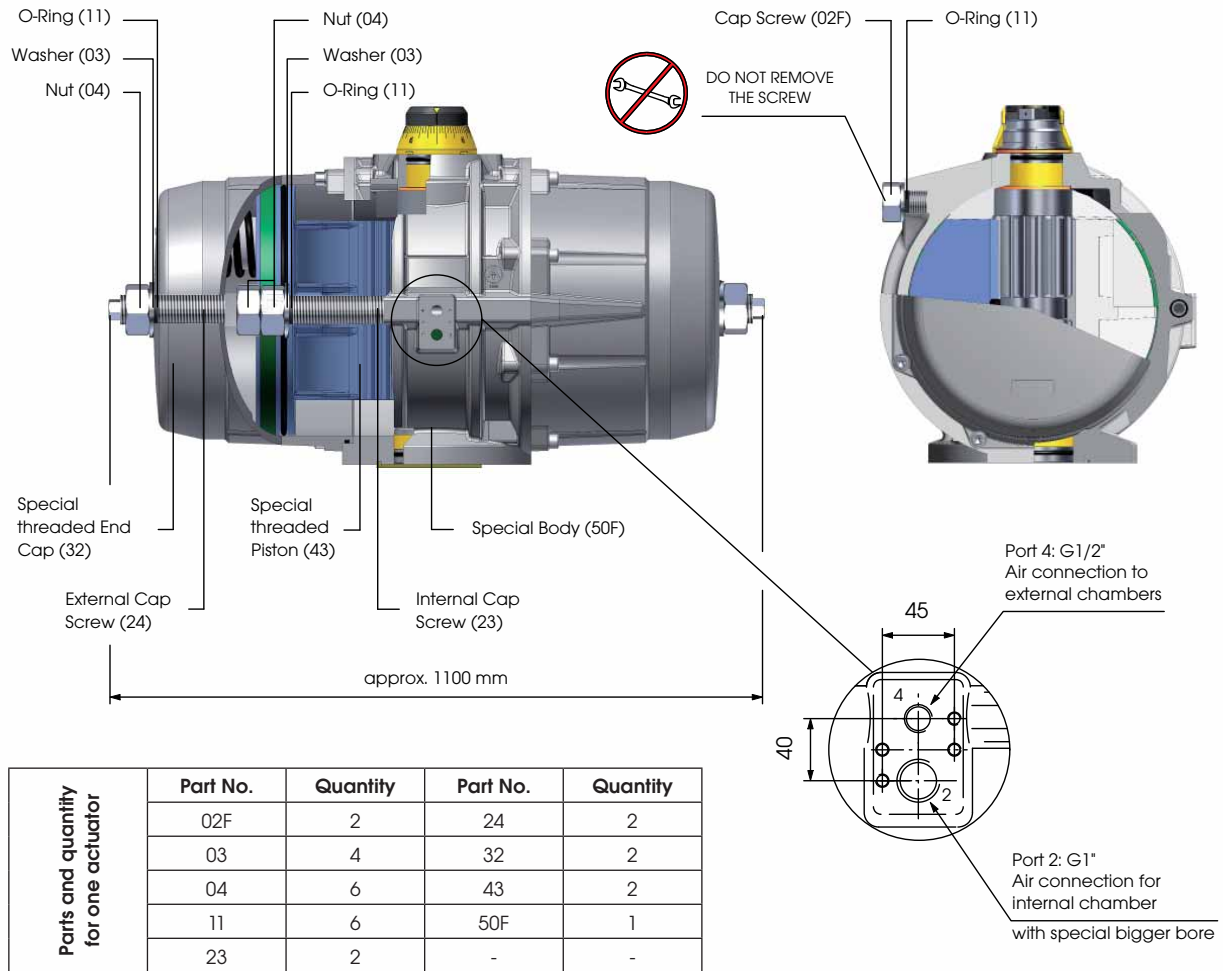

Technical Data and Operating Times:

Actuator Type	Air Connection Size Port 2	Air Connection Size Port 4	Air Bore (mm)		* minimum Operating Time (sec.)			
			Port 2	Port 4	Spring Return		Double Acting	
					OPEN	CLOSE	OPEN	CLOSE
FA DR/SC10000U	G 1"-ISO228	G 1/2"-ISO228	ø21	ø13	1,5	1,4	1,5	1,4

Test Condition:

* The MINIMUM Operating Time indicated is obtained in the following test conditions:
(1) Room Temperature, (2) SC -> Spring Return Actuator with maximum number of springs per side, Stroke: 90°; DR -> Double Acting Actuator, Stroke: 90° (3) Minimum inside diameter for air supply circuit equal to air bore Port 2, (4) Medium clean air, (5) Air supply pressure: 6bar (87psi), (6) Actuator without external resistance load, (7) Supply circuit without solenoid valve.

Attention: The indicated operating times are strictly related to the above test conditions. The operating times on the field applications are different depending on the working conditions.

Note:

For other dimensions see catalogue or technical data sheet.
For maintenance and installation see manual instruction. Fast Acting actuator cycle life may result lower than for the standard actuators in relation to the field conditions.



EDITION 2010
 Extreme Low Temp. LLT
 -55°C (-67°F) bis +80°C (+176°F)



AIR TORQUE
 PNEUMATISCHE STELLANTRIEBE

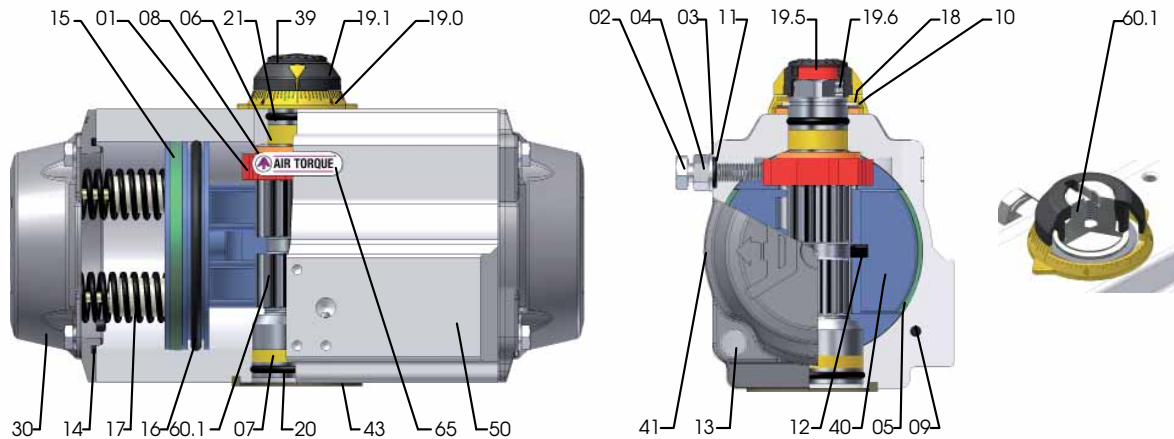

Part No.	Qty.	Note	Description	Standard Material / Corrosion Protection
01	1	n/a for DR/SC00010U	Octi-Cam (Stop arrangement)	Stainless Steel (only for DR/SC00015U - 00150U) Carbon Steel / Nodular Cast Iron, zinc coated
02	2	n/a for DR/SC00010U	Stop Cap Screw	Stainless Steel A2 70 (ISO 3506)
03	2	n/a for DR/SC00010U	Washer	Stainless Steel A2 (ISO 3506)
04	2	n/a for DR/SC00010U	Nut (Stop screw)	Stainless Steel A2 70 (ISO 3506)
05*	2	4 Stk. for DR/SC10000U	Bearing (Piston back)	PA46
06*	1	for DR/SC00010U - DR/SC00030U for DR/SC00060U - DR/SC10000U	Bearing (Pinion top)	PA46 HGP
07*	1	for DR/SC00010U - DR/SC00030U for DR/SC00060U - DR/SC10000U	Bearing (Pinion bottom)	PA46 HGP
08*	2	1 pcs. for DR/SC00010U	Thrust Bearing (Pinion)	PA46
09*	2	for DR/SC00010U - DR/SC04000U for DR/SC05000U - DR/SC10000U	Plug	Silicone
10	1		Thrust Washer (Pinion)	Stainless Steel AISI 304
11*	2	n/a for DR/SC00010U	O-Ring (Stop screw)	Special Silicone
12	2		Piston Guide	PA66+GF
13	8 12 16	for DR/SC00010U - DR/SC02000U for DR/SC03000U and DR/SC04000U for DR/SC05000U and DR/SC10000U	Cap Screw	Stainless Steel A2 70 (ISO 3506)
13.1	16	for DR/SC10000U	Washer (Cap screw end cap)	Stainless Steel A2 (ISO 3506)
14*	2		O-Ring (End cap)	Special Silicone
15*	2		Bearing (Piston head)	POM
16*	2		O-Ring (Piston)	Special Silicone
17	max. 12	for DR/SC00030U - DR/SC10000U	Spring (Cartridge)	SiCr Spring alloy Steel, coated
17.1	max. 2	for DR/SC00010U - DR/SC00015U	Spring	SiCr Spring alloy Steel, coated
17.2	max. 2	for DR/SC00010U - DR/SC00015U	Spring	SiCr Spring alloy Steel, coated
17.3	max. 2	for DR/SC00010U - DR/SC00015U	Spring	SiCr Spring alloy Steel, coated
18	1		Spring Clip (Pinion)	Stainless Steel AISI 302
19	1	for DR/SC00010U - DR/SC00030U	Position Indicator	PA66+GF+CB / Stainless Steel
19.0	1		Graduated Ring	PA66+GF+(CB)
19.1	1	n/a for DR/SC00010U - DR/SC00030U	Position Indicator	PA66+GF+CB
19.5	1	n/a for DR/SC00010U, only for DR/SC10000U	Top Adaptor	Extruded Aluminium alloy, anodized
19.6	2	n/a for DR/SC00010U, only for DR/SC10000U	Hex. Socket Screw (Top Adaptor)	Stainless Steel
20*	1		O-Ring (Pinion bottom)	Special Silicone
21*	1		O-Ring (Pinion top)	Special Silicone
30	2	for DR/SC00010U - DR/SC04000U for DR/SC05000U and DR/SC10000U	End Cap	Pressure Die Cast Aluminium alloy, anodized and coated Cast Aluminium alloy, anodized and coated
39	1		Cap Screw (Indicator)	PA66+GF+CB
40	2	for DR/SC00010U - DR/SC04000U für DR/SC05000U and DR/SC10000U	Piston	Pressure Die Cast Aluminium ally, anodized Cast Aluminium alloy, anodized
41	1		Label	Polyester-Silver
42	2	only for DR/SC00010U, 5000U and 10000U	End Cap Label	Polyester-Silver
43	1		Spigot (Only on request)	Extruded Aluminium alloy, anodized
50	1	for DR/SC05000U and DR/SC10000U	Body	Extruded Aluminium alloy, coated Cast Aluminium alloy, coated
60	1	only for DR/SC00010U and DR/SC10000U	Drive Shaft	Extruded Aluminium alloy, anodized
60.1	1	for DR/SC00015U - DR/SC05000U	Integral Drive Shaft	Stainless Steel AISI 316 (1,4401), E.N.P.
65	1		Plastic Insert	PA66 modified

Notes: *suggested SPARE PARTS for maintenance
 Lubricant: GLLT Grease; For operation installation and maintenance see the manual for use and maintenance.

Technical Data:

Operating Temperature: -55°C (-67°F) to +80°C (+176°F) / **up to -60°C (-76°F) only for short period of time.**
 Operating Time: to be verified on each application depending on working conditions.
 Working Pressure: max. 8 bar
 Operating Media: dry or lubricated air or inert/non-corrosive gases provided they are compatible with internal actuator parts and lubricant.
 The operating media must have a dew point equal at least 10°C below the ambient temperature. The maximum particle size must not exceed 30µm.



EDITION 2010
Pneumatic Actuators
Operating Media Water



AIR TORQUE
PNEUMATISCHE STELLANTRIEBE

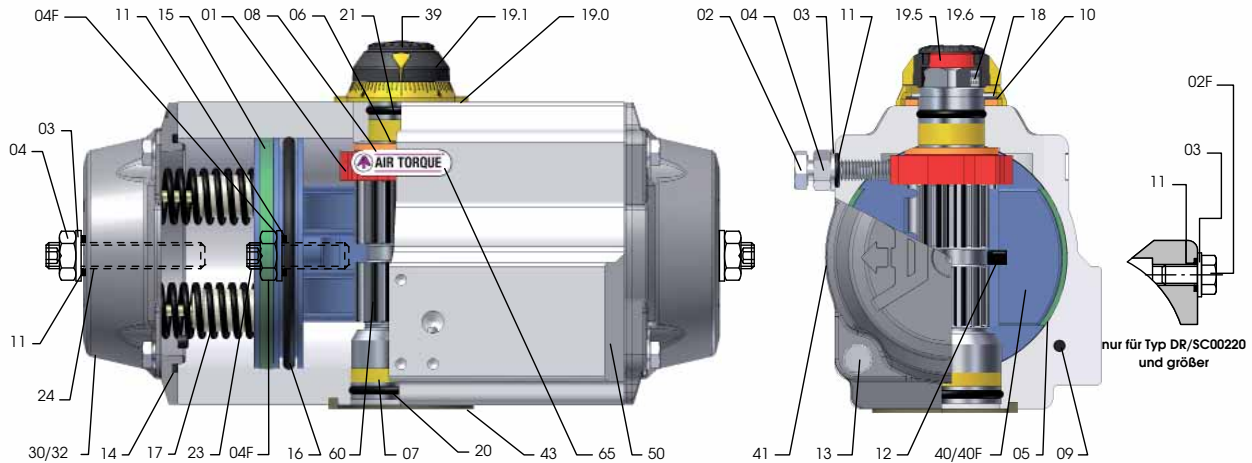

PartNo.	Qty	Description	Material	Specification	Corrosion Protection**
01	1	Octi Cam only for model DR/SC00015U - 00150U	Stainless Steel	-	-
02	2	Stop Cap Screw for DR/SC00015U - 00150U	A2 70	ISO 3506-1	-
02F	2	Cap Screw only for DR/SC00220U - 10000U	A2 70	ISO 3506-1	-
03	2 / 6	Washer	1.4301	UNI EN 10088-2	-
04	2 / 4	Nut (Stop screw)	A2 70	ISO 3506-2	-
04F	2	Nut (Screw internal stroke adj.) only for model DR/SC00220U - 1000U	A2 70	ISO 3506-2	-
05*	2	Bearing (Piston back)	POM	-	-
06*	1	Bearing (Pinion top) for model DR/SC00010U - 00030U Bearing (Pinion top) for model DR/SC00060U - 10000U	POM HGP	- -	- -
07*	1	Bearing (Pinion bottom) for model DR/SC00010U - 00030U Bearing (Pinion bottom) for model DR/SC00060U - 10000U	POM HGP	- -	- -
08*	2	Thrust Bearing (Pinion)	POM	-	-
09*	2	Plug for model DR/SC00010U - 04000U Plug for model DR/SC05000U - 10000U	Silicone M-NBR	- -	- -
10	1	Thrust Washer (Pinion)	1.4301	UNI EN 10088-2	-
11*	2 / 6	O-Ring (Stop screw)	M-NBR	-	-
12	2	Piston Guide	PA66+GF	-	-
13	8	Cap Screw (End cap) for model DR/SC00010U - 02000U	A2 70	ISO 3506-1	-
	12	Cap Screw (End cap) for model DR/SC03000U - 04000U	A2 70	ISO 3506-1	-
	16	Cap Screw (End cap) for model DR/SC05000U - 10000U	A2 70	ISO 3506-1	-
14*	2	O-Ring (End cap)	M-NBR	-	-
15*	2	Bearing (Piston head)	HGP	-	-
16*	2	O-Ring (Piston)	M-NBR	-	-
17	min. 5 max. 12	Spring (Cartridge)	SiCr Spring Alloy Steel	UNI EN 10270-2	Standard
18	1	Spring Clip (Pinion)	C75	UNI EN 10132-4	Standard
19.0	1	Graduated Ring for model DR/SC00010U - 10000U	PA66+GF(+CB)	-	-
19.1	1	Position Indicator	PA66+GF+CB	-	-
19.5	1	Top Adaptor for DR/SC00060U - 10000U	Aluminium 6026	UNI EN 573/3	-
19.6	2	Hex. Socket Screw (Top adaptor)	A2 70	ISO 3506-1	-
20*	1	O-Ring (Pinion bottom)	M-NBR	-	-
21*	1	O-Ring (Pinion top)	M-NBR	-	-
23	2	Screw (internal stroke adj.) only for model DR/SC00220U - 10000U	A2 70	ISO 3506-1	-
24	2	Screw (external stroke adj.) only for model DR/SC00220U - 10000U	A2 70	ISO 3506-1	-
30	2	End Cap for model DR/SC00010U - 00150U	EN AC-46000	UNI EN 1706	Anodized + Polyester coated
32	2	End Cap for model DR/SC00220U - 05000U (threaded) End Cap for model DR/SC10000U (threaded)	EN AC-46000 EN AC-42100	UNI EN 1706 UNI EN 1706	Anodized + Polyester coated Anodized + Polyester coated
39	1	Cap Screw (Indicator)	PA66+GF+CB	ISO 3506-1	-
40	2	Piston for model DR/SC00010U - 00150U	EN AC-46000	UNI EN 1706	Standard
40F	2	Piston for model DR/SC00220U - 05000U (threaded) Piston for model DR/SC10000U (threaded)	EN AC-46000 EN AC-46400	UNI EN 1706 UNI EN 1706	Standard Standard
41	1	Identification Label	Polyester-Silver	RC 45	-
43	1	Spigot (on request)	Extr. All. EN AW-6063	UNI EN 573/3	Standard
50	1	Body for model DR/SC00010U - 04000U Body for model DR/SC05000U and 10000U	Extr. All. EN AW-6063 All. EN AC-42100	UNI EN 573/3 UNI EN 1706	Standard Standard
60	1	Drive Shaft for model DR/SC00010U - 10000U	1.4401 / 316	EN 10088-3 / ASTM A582	Standard
65	1	Plastic Insert for model DR/SC00015U - 03000U	Modified PA66	-	-

Notes:

* Suggested SPARE PARTS for maintenance.
** For other kinds of standard protection see manual.
Lubricant: STD Grease
For maintenance and/or spare parts refer to the manual.

Technical Data:

Operating Temperature: +1°C to +80°C
Operating Time: depending on each application a. working conditions
Arbeitsdruck: max. 8bar
Wasserqualität: Clean Water



DR/SC00015U - DR/SC10000U

Special threaded
End Cap (32)

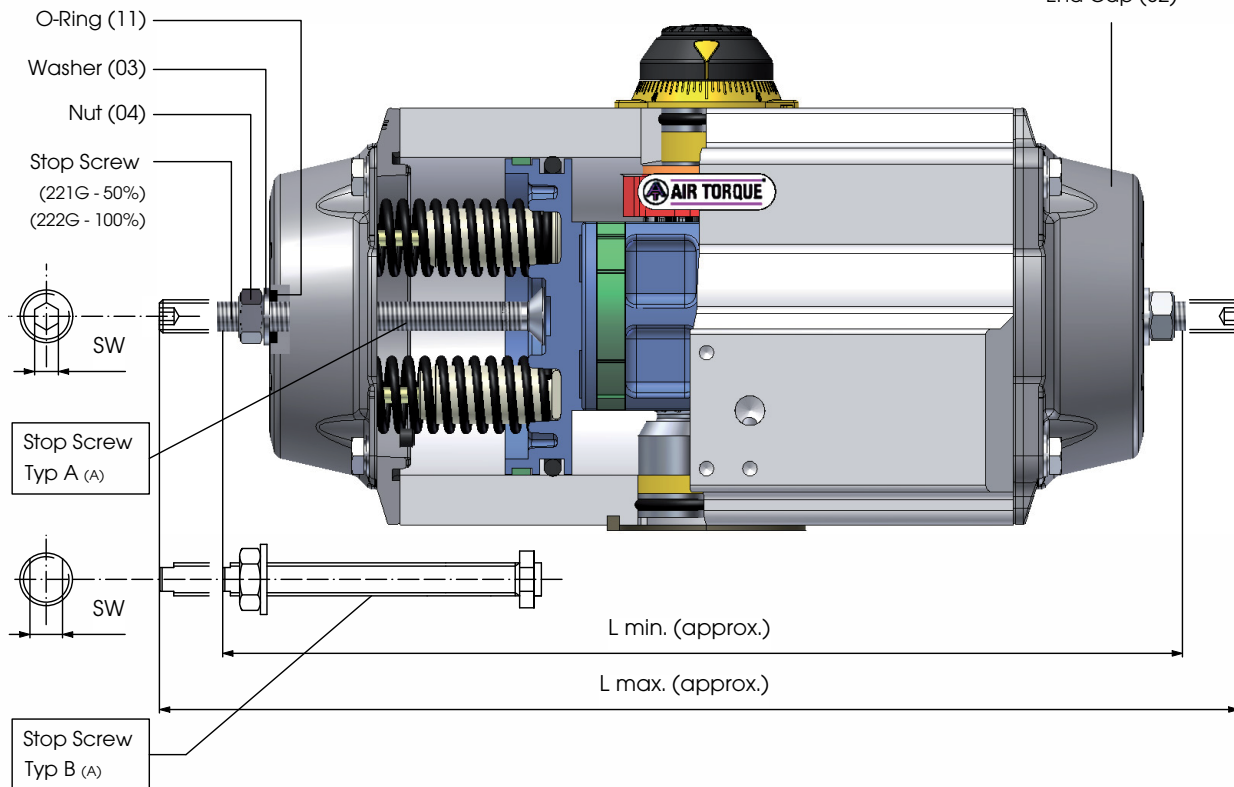

Parts and Quantity for one Actuator	Part No.	Quantity	Part No.	Quantity
	03	2	221...G (50%)	2
	04	2	222...G (100%)	2
	32	2		

Note:

(A) - For the type of the screw see the table.

Actuator with Travel Stop for 50% stroke adjustment (90°-45°)

DR/SC U ... B 50%	00015	00030	00060	00100	00150	00220	00300	00450	00600	00900	01200	02000	03000	04000	05000	10000
L min. mm	162	180	244	270	296	365	371	453	468	521	624	659	760	995	918	1060
L max. mm	176	196	266	295	324	399	409	497	515	571	680	725	838	1080	1006	1160
Stop Screw	A-SW3		A-SW4		A-SW5	B-SW8		B-SW10		B-SW10	B-SW13		B-SW17	B-SW22	B-SW22	B-SW30

Actuator with Travel Stop for 100% stroke adjustment (90°-0°)

DR/SC U ... B 100%	00015	00030	00060	00100	00150	00220	00300	00450	00600	00900	01200	02000	03000	04000	05000	10000
L min. mm	158	184	242	280	303	356	368	449	461	531	628	653	762	910	910	1060
L max. mm	186	216	286	330	359	424	444	537	555	631	739	785	918	1080	1086	1260
Stop Screw	A-SW3		A-SW4		A-SW5	B-SW8		B-SW10		B-SW10	B-SW13		B-SW17	B-SW22	B-SW22	B-SW30



STAINLESS STEEL Actuators Technical Data

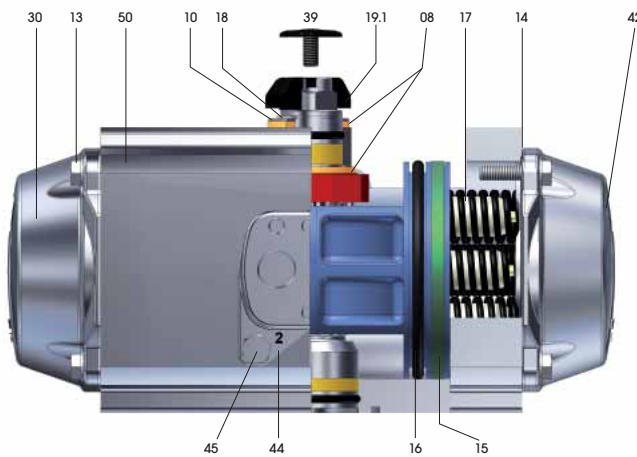

only for size DRSC00450S and bigger

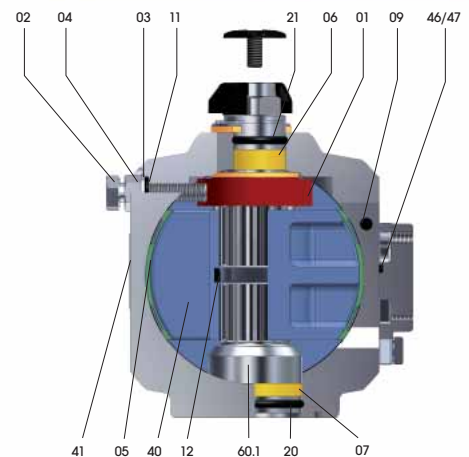
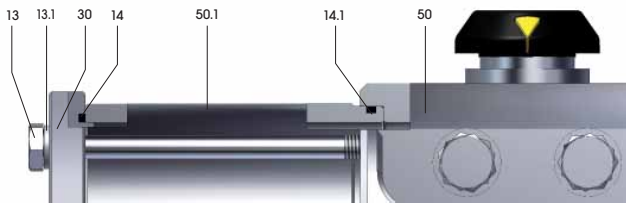

only for size DRSC00015US



Part No.	Spare Parts	Quantity / Note	Description	Specification
01		1	OCTI-Cam (Stop arrangement)	Stainless Steel (only for DRSC00015S - DRSC00150S) Carbon Steel, zinc coated
02		2	Stop Cap Screw	Stainless Steel A2 70 (ISO 3506) / optional Stainless Steel A4 70
03		2	Washer	Stainless Steel A2 (ISO 3506) / optional Stainless Steel A4
04		2	Nut (Stop screw)	Stainless Steel A2 70 (ISO 3506) / optional Stainless Steel A4 70
05	○	2	Bearing (Piston back)	High-grade polymers
06	○	1	Bearing (Pinion top)	High-grade polymers
07	○	1	Bearing (Pinion bottom)	High-grade polymers
08	○	2	Thrust bearing (Pinion)	High-grade polymers
09	○ □	2	Plug	M-NBR / Silicone
10		1	Thrust washer	Stainless Steel AISI 304
11	○ □	2	O-Ring (Stop screw)	M-NBR
12		2	Piston guide	High-grade polymers
13		8	Cap screw	Stainless Steel A4 70 (ISO 3506)
13.1		8	Washer	Stainless Steel A4 (ISO 3506)
14	○ □	2	O-Ring (End cap)	M-NBR
14.1	○ □	2	O-Ring (Body extension)	M-NBR
15	○	2	Bearing (Piston head)	High-grade polymers
16	○ □	2	O-Ring (Piston)	M-NBR
17		max.12	for DRSC00030S-DRSC02000S	Spring (Cartridge)
17.1		max.4	Spring	SiCr Spring alloy steel coated
17.2			Spring	
17.3			Spring	
18		1	Spring clip (Pinion)	Stainless Steel AISI 302
19.1		1	Position indicator	High-grade polymers
20	○ □	1	O-Ring (Pinion bottom)	M-NBR
21	○ □	1	O-Ring (Pinion top)	M-NBR
30		2	for DRSC00015S-DRSC00300S for DRSC00450S a. bigger	End cap Stainless Steel 1.4408 (EN 10283) / CF8M (ASTM A351), ENP Stainless Steel 1.4401 (EN 10088-3) / F316 (ASTM A 182), ENP
39		1	Cap screw (Indicator)	High-grade polymers
40		2	Piston	Pressure Die Cast Aluminium alloy, anodized
41		1	Label	Polyester-Silver
42		2	End cap label	Polyester-Silver
44		1	NAMUR connection plate	Stainless Steel 1.4401 (EN 10088-3) / F316 (ASTM A 182), for DRSC00015S Stainless Steel 1.4408 (EN 10283) / CF8M (ASTM A351)
45		2	Cap screw (Connection plate)	Stainless Steel A4 70 (ISO 3506)
46	○ □	1	O-Ring port 2 (Connection plate)	M-NBR
47	○ □	1	O-Ring port 4 (Connection plate)	M-NBR
50		1	Body	Stainless Steel 1.4401 (EN 10088-3) / F316 (ASTM A 182), ENP
50.1		2	not for DRSC00450S a. bigger	Body extensions Stainless Steel 1.4401 (EN 10088-3) / F316 (ASTM A 182), ENP
60.1		1	Integral drive shaft	Stainless Steel 1.4401 (EN 10088-3) / F316 (ASTM A 182), ENP

○ Parts included in Spare Part Kit

□ Parts included in O-Ring Kit

Air Torque GmbH

Im Katzentach 16-18 · DE - 76275 Ettlingen
Tel.: +49 (0)7243 59 34-0 · Fax : +49 (0)7243 59 34-34
info@airtorque.de · www.airtorque.de

Modifications reserved. Date 12.2011.
No guarantee for accuracy.
Older data sheets are invalid.



STAINLESS STEEL Actuators Technical Data



AIR TORQUE
PNEUMATISCHE STELLANTRIEBE

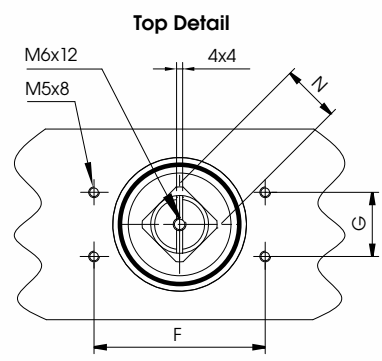
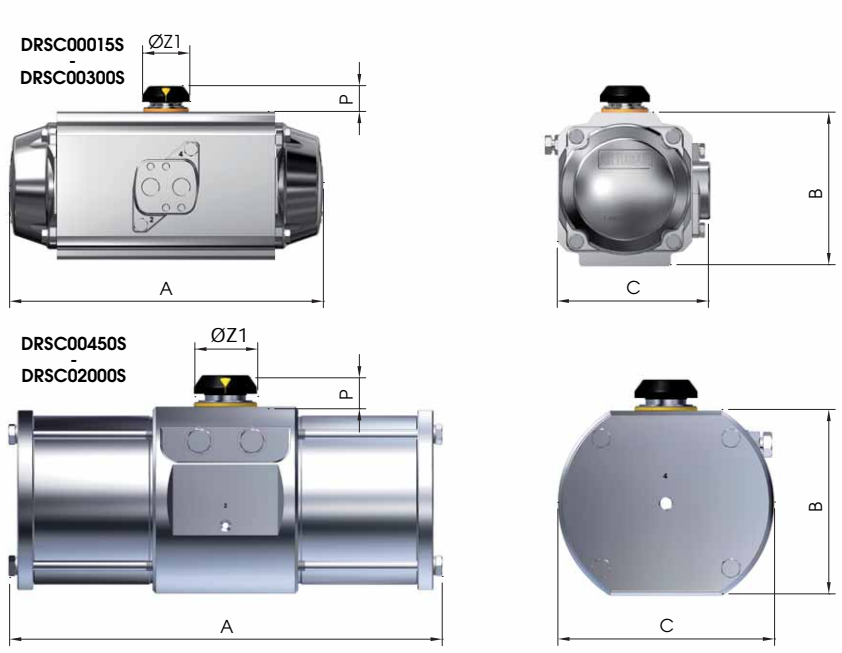

Air Connection VDI/VDE 3845

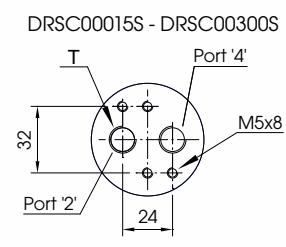

DRSC00450S - DRSC02000S

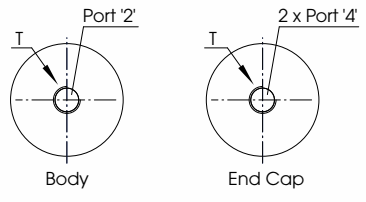

Actuator Type	DRSC 00015S	DRSC 00030S	DRSC 00060S	DRSC 00100S	DRSC 00150S	DRSC 00300S	DRSC 00450S	DRSC 00900S	DRSC 02000S
A	141	159	211	248	268	345	412	492	630
B	69	85	102	115	127	157	177	220,5	298,5
C (ca.)	75	86	99	114	128	159	210	250	335
F	80	80	80	80	80	80	80	130	130
G	30	30	30	30	30	30	30	30	30
N	11	11	17	17	17	27	27	36	36
P	20	20	20	20	20	30	30	50	50
T ISO 228*	1/8"	1/4"	1/4"	1/4"	1/4"	1/4"	1/4"	1/4"	3/8"
ØZ1	37	37	37	37	37	51	60	68	104
ISO Flange	F04	F05	F05 + F07	F05 + F07	F07 + F10	F07 + F10	F10 + F12	F14	F16
Q	42	50	50	50	70	70	102	140	165
Q1	-	-	70	70	102	102	125	-	-
W	M5	M6	M6	M6	M8	M8	M10	M16	M20
W1	-	-	M8	M8	M10	M10	M12	-	-

optional ISO Flange		F03	-	-	-	-	-	F10 + F12	-	
SW x I min.	DS	9x11	11x12	14x16	17x19	17x19	22x24	27x29	27x29	36x39
		11x12	14x16	17x19	-	22x24	27x29	-	36x39	46x49

*NPT (ANSI B1-20-1) Threads available on request only for DRSC00015S - DRSC00300S.

Actuator Type	00015S		00030S		00060S		00100S		00150S		00300S		00450S		00900S		02000S	
	DR	SC	DR	SC	DR	SC	DR	SC	DR	SC	DR	SC	DR	SC	DR	SC	DR	SC
OPEN Time (A) (sec.)	0,2	0,25	0,25	0,3	0,3	0,4	0,4	0,5	0,5	0,7	0,9	1,2	1,2	1,5	2	2,4	3,5	4,1
CLOSE Time (A) (sec.)	0,2	0,3	0,3	0,35	0,35	0,5	0,5	0,6	0,6	0,9	1,1	1,4	1,4	1,8	2,2	2,8	4	4,6
Air Volume OPEN (L)	0,09		0,16		0,31		0,51		0,71		1,54		2,41		4,26		10	
Air Volume CLOSE (L)	0,15		0,26		0,49		0,78		1,11		2,34		3,78		6,89		15,2	
Weight approximate (kg)	2,7	2,9	3,8	4,0	6,0	6,4	8,8	9,4	12,3	13,3	22,6	24,5	34,6	37,7	58	65	135	150

Note: (A) The above moving times of the actuator are obtained in the following test conditions:
For model DRSC00015S - DRSC00450S: (1) Room Temperature, (2) Actuator Stroke 90°, (3) Solenoid Valve with orifice of 4 mm and a flow capacity of Qn 400L/min., (4) Inside pipe diameter 8 mm, (5) Medium clean air, (6) Air supply pressure 5,5 bar (79,75 Psi), (7) Actuator without external resistance load.

For model DRSC00900S - DRSC02000S: (1) Room Temperature, (2) Actuator Stroke 90°, (3) Solenoid Valve with orifice of 11 mm and a flow capacity Qn 6000L/min., (4) Inside pipe diameter 11 mm, (5) Medium clean air, (6) Air supply pressure 5,5 bar (79,75 Psi), (7) Actuator without external resistance load.

Cautions: Obviously on the field applications, when one or more of the above parameter are different, the moving time will be different.

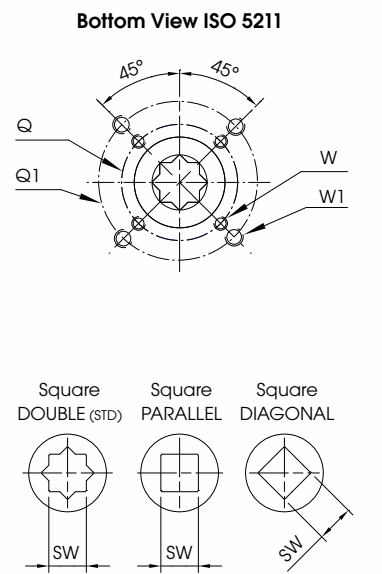



DR/SC00015U - 00030U

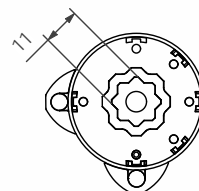
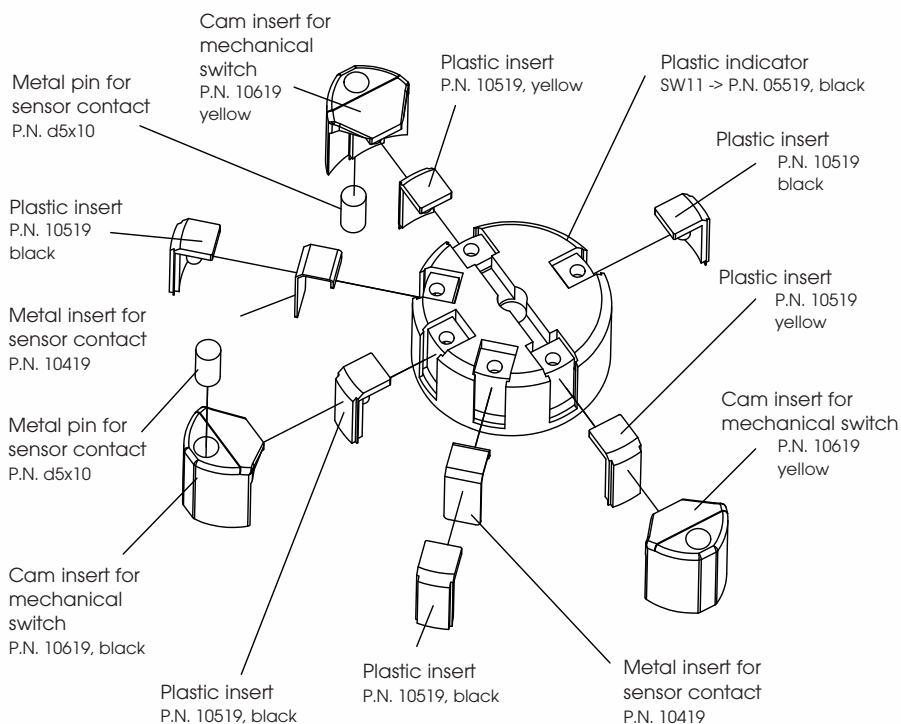

Dimensions in (mm)

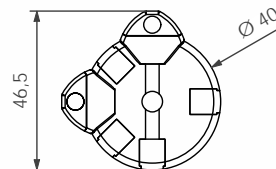
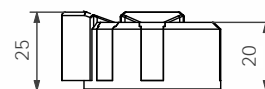

DR/SC00060U - 00150U

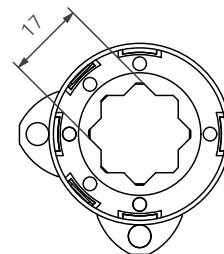
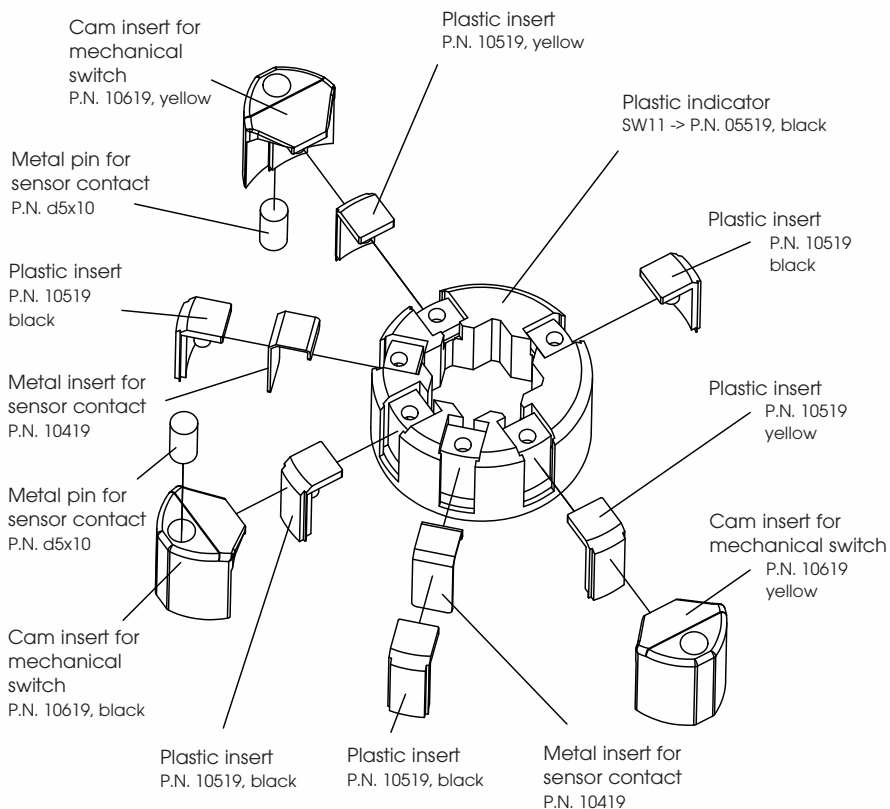

Dimensions in (mm)

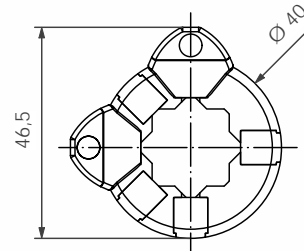
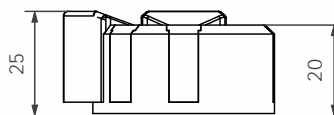



EDITION 2010 Accessories
Multifunction Indicator
DR/SC00220U - 10000U



AIR TORQUE

PNEUMATISCHE STELLANTRIEBE

DR/SC00220U - 00600U

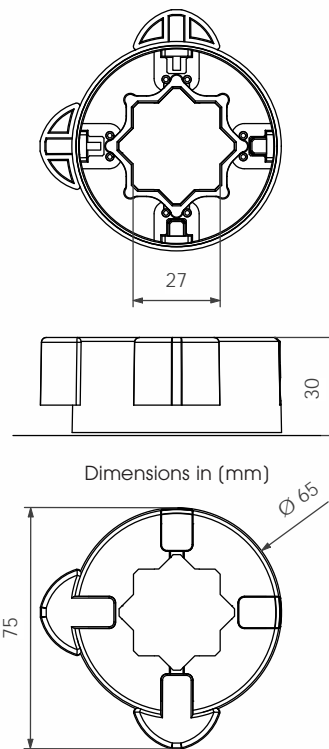
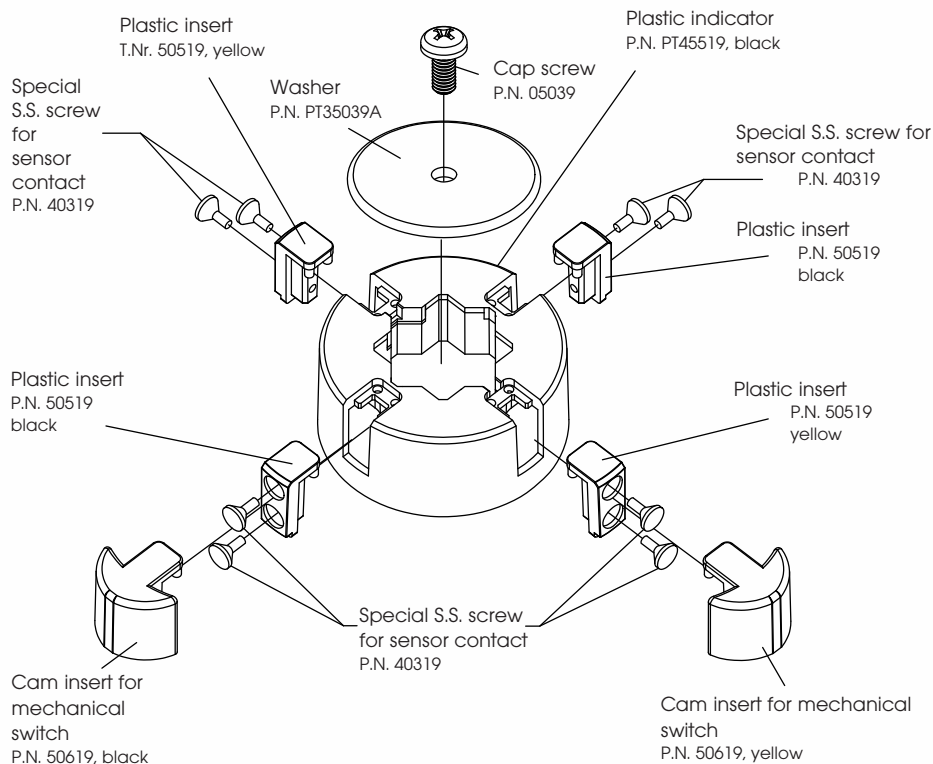

DR/SC00900U - 10000U

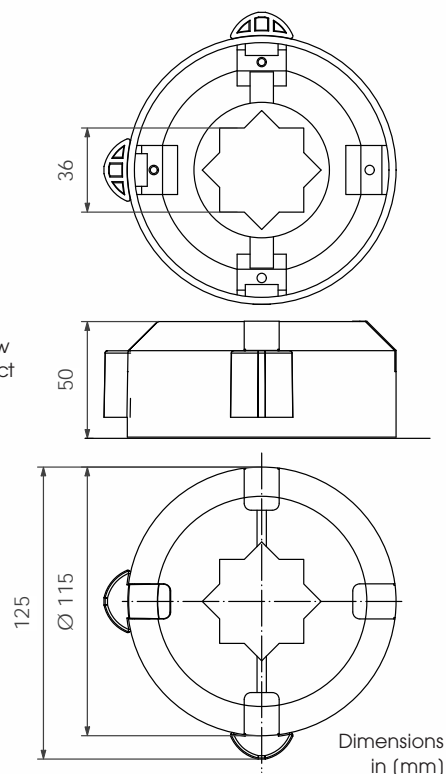
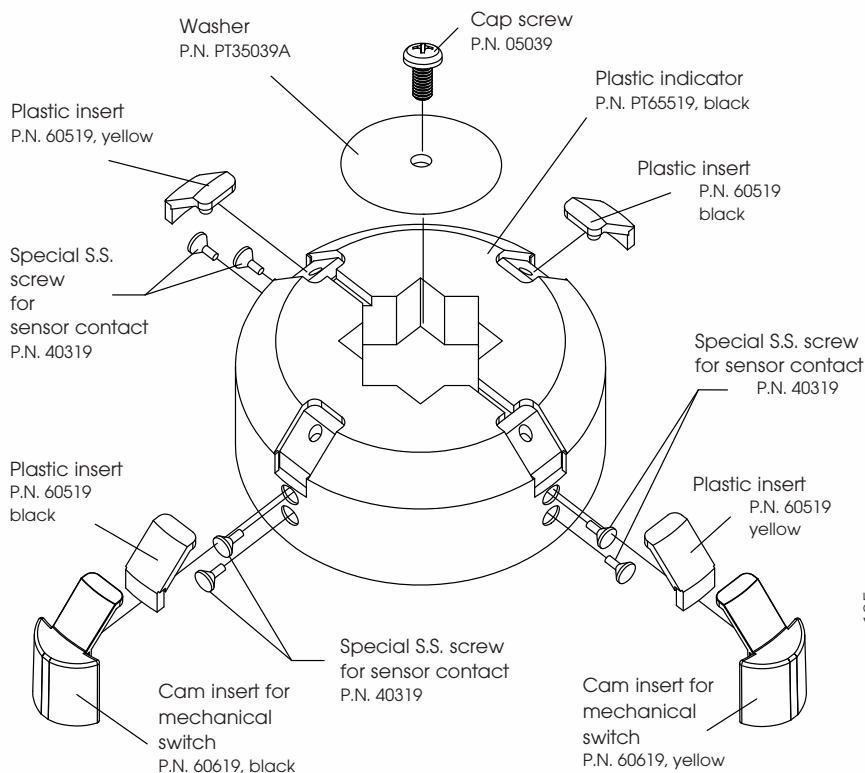



Adaptors:

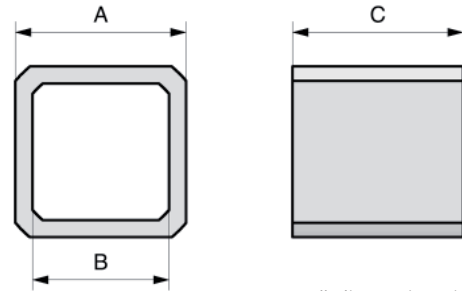
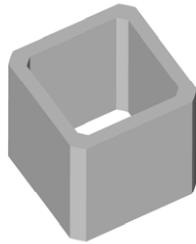

all dimensions in [mm]

Part No.	A SW external	B SW internal	C
ADH11/09	11	9	11
ADH14/09	14	9	16
ADH14/10	14	10	16
ADH14/11	14	11	14
ADH14/12	14	12	16
ADH17/10	17	10	17
ADH17/11	17	11	17
ADH17/12	17	12	17

Part No.	A SW external	B SW internal	C
ADH17/14	17	14	17
ADH22/16	22	16	22
ADH22/17	22	17	22
ADH27/22	27	22	27
ADH27/24	27	24	27
ADH36/27	36	27	36
ADH36/30	36	30	36
ADH55/46	55	46	55

Centering:

Design A:

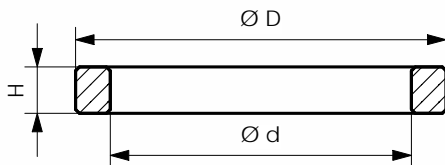

Design B:

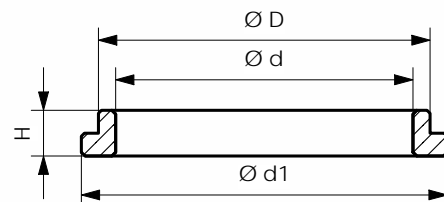

Type	ISO Flange	Part No.	D (f8)	d	d1	H	Design
00010	F03	ZRF03/S03	25	21,7	/	3	A
	F04	ZRF04/S04	30	25	/	3,5	A
00015	F03+F05	ZRF03/S03 (only F03)	25	21,7	/	3	A
	F04	ZRF04/S04	30	25	/	3,5	A
00030	F03+F05	ZRF03/S03 (only F03)	25	21,7	/	3	A
	F04+F07	ZRF04/S04 (only F04)	30	25	/	3,5	A
	F05+F07	ZRF05/S05 (only F05)	35	30	/	4	A
00060	F05	ZRF05/S052	35	32,2	/	4	A
	F05+F07	ZRF05/S052 (only F05)	35	32,2	/	4	A
00100	F07	ZRF07/S07	55	48	/	4,5	A
	F05+F07	ZRF05/CRD2530 (only F05)	35	28	40	3,8	B
00150	F07	ZRF07/S07	55	48	/	4,5	A
	F05+F07	ZRF05/CRD2530 (only F05)	35	28	40	3,8	B
	F07+F10	ZRF07/S07 (only F07)	55	48	/	4,5	A
	F10	ZRF10/S10	70	62	/	5	A
00220	F07+F10	ZRF07/S07 (only F07)	55	48	/	4,5	A
	F10	ZRF10/S10	70	62	/	5	A
00300	F07+F10	ZRF07/S07 (only F07)	55	48	/	4,5	A
	F10	ZRF10/S10	70	62	/	5	A

Type	ISO Flange	Part No.	D (f8)	d	d1	H	Design
00450	F10+F12	ZRF10/S10 (only F10)	70	62	/	5	A
	F12	ZRF12/S12	85	76	/	6	A
00600	F10+F12	ZRF10/S10 (only F10)	70	62	/	5	A
	F12	ZRF12/S12	85	76	/	6	A
00900	F10+F12	ZRF12/S12 (only F12)	85	76	/	6	A
	F12	ZRF12/S12	85	76	/	6	A
	F14	ZRF14/S14	100	90	/	7	A
01200	F10+F12	ZRF12/S126 (only F12)	85	78	/	4,5	A
	F14	ZRF14/S14	100	90	/	7	A
02000	F14	ZRF14/S14	100	90	/	7	A
	F16	ZRF16/S16	130	120	/	9	A
03000	F16	ZRF16/S16	130	120	/	9	A
04000	F16	ZRF16/S16	130	120	/	9	A
	F16+F25	ZRF16/S16	130	120	/	9	A
		ZRF25/S25	200	187	/	9	A
05000	F16+F25	ZRF25/S25 (only F25)	200	187	/	9	A
10000	F16+F25+F30	ZRF25/S25 (only F25)	200	187	/	9	A



INSTALLATION, MAINTENANCE AND OPERATING INSTRUCTION MANUAL

For ACTUATORS EDITION 2010:

- **DR/SC** • **Double acting "DR" and Spring return "SC"** • **90°-180° Stroke**

1. GENERAL	P.0901e	6. MAINTENANCE INSTRUCTIONS	P.0903e
2. WARNING	P.0901e	7. STORAGE INSTRUCTIONS	P.0907e
3. WORKING CONDITIONS AND TECHNICAL DATA	P.0901e	8. LIFTING AND HANDLING	P.0907e
4. OPERATING FUNCTION AND DIRECTION OF ROTATION	P.0902e	9. NOTES REGARDING THE FLANGE CONNECTION	P.0907e
5. INSTALLATION INSTRUCTIONS	P.0902e		

1. GENERAL

This instruction manual contains important information regarding the installation, operation, maintenance and storage for AIR TORQUE rack and pinion pneumatic actuators. Please read these instructions carefully and keep them for future reference. It is important that the use and maintenance of the actuator is made only by properly trained personnel.

2. WARNING

- Do not operate the actuator using inflammable, oxidizing, corrosive, explosive or unstable gases or liquids (use only not dangerous fluids – group 2 according to 97/26/EC directive). Moreover, for actuators installed in potentially explosive zones, make sure that the internal parts of the actuator do not come into contact with the external atmosphere.
- Referring to the Machinery Directive 2006/46/EC, the actuators can be classified as "PARTLY COMPLETED MACHINERY" (see the DECLARATION OF INCORPORATION). Therefore the actuator can not put into service until the machinery and/or the system, where the actuator is incorporated, will be declared in compliance with the requirements of the Directive 2006/42/EC.
- Air Torque actuators are designed, produced and classified according to the ATEX Directive 94/9/EC (see actuator label and safety instructions). The use of the actuators in potential explosive atmosphere zones has to comply with the ATEX classification indicated on the actuator label and according to the ATEX safety instructions.
- The use, the installation and the maintenance of the Air Torque actuators must be made by adequately trained personnel. For the use, installation and maintenance of Air Torque actuators it is recommended to comply to the safety notice and to use proper equipment to protect health and prevent accidents.
- It is important that the actuator is used only within the working limits indicated in the technical specifications.
- Do not operate the actuator over temperature limits: this could damage internal and external components (disassembly of spring return actuator may become dangerous).
- Do not operate the actuator over pressure limits: this could damage internal parts as well as cause damage to the housing and end-caps.
- Do not use the actuator in corrosive environments with incorrect protection: this could damage the internal and external parts.
- Do not disassemble individual spring cartridges, this may result in personal injury. If maintenance to springs is necessary, send them to AIR TORQUE.
- Close and disconnect all air supply lines and make sure that air connections are vented during maintenance and installation on valve.
- Do not disassemble the actuator or remove end caps while the actuator is pressurized.
- The 4TH GENERATION Upgrade Series actuators are designed to be used only on valves.
- Before installing the actuator onto the valve make sure that the rotation direction and the position indicator are in the correct position.
- If the actuator is incorporated in a system or used within safety devices or circuits, the customer shall ensure that the national and local safety laws and regulations are observed.

3. WORKING CONDITIONS AND TECHNICAL DATA

- Operating media:
Dry or lubricated air or inert gases, provided that they are compatible with the actuator internal parts and lubricant. The operating media must have a dew point equal to -20°C (-4°F) or at least 10°C below the ambient temperature. The maximum particle size contained into the operating media must not exceed 30 µm.
- Supply pressure:
The maximum supply pressure is 8 bar (116 Psi), only for AT801U it is 7 bar (101,5 Psi).
For double acting and spring return actuators the working pressure is from 2.5 bar (36 Psi) to 8 bar (116 Psi).
- Operating temperature:
==> "Standard" actuators from -40°C (-40°F) to +80°C (+176°F)
==> Actuators for high temperature "HT" from -15°C (+5°F) to +150°C (+300°F)
==> Actuators for extreme low temperature "LLT" from -55°C (-67°F) to + 80°C (+176°F)
Caution: for low and high temperature service, special grease and special components are required. Please contact AIR TORQUE. Working at high or low temperature can affect the life and the output torque of the actuator.
- Operating time (see technical data sheet):
Caution: the operating time depends on several factors such as supply pressure, supply system capacity (pipe diameter, flow capacity of pneumatic accessories), valve type, valve torque and figures, applied safety factor, cycle frequency, temperature, etc.
- Rotation and stroke adjustment (see technical data sheet):
For standard actuators (90° rotation), 120° actuators (120° rotation), 135° actuators (135° rotation) and 180° actuators (180° rotation).
Stroke adjustment at 0°(closed pistons): +15°max/ - 5°. Stroke adjustment at 90°, 120°, 135° and 180°(open pistons): +5°/-15°max. For actuator AT045U the stroke adjustment at 90° (open pistons) is available only on request.
- Lubrication:
The actuators are factory lubricated for the life of the actuator in normal working conditions.
The standard lubricant type GSTD is suitable for use from -40°C (-40°F) to +80°C (+176°F).
For extreme low temperature (LLT) and high temperature (HT) service, special grease is required: please contact Air Torque.
- Construction: Rack and pinion actuator design suitable for both indoor or outdoor installations.
- Protection and corrosion resistance:
All the actuators are supplied with corrosion protection for normal environments. For corrosion resistance of the different types of protection see technical data sheet. Before installing the actuator in aggressive environment, ensure that the selected protection level is suitable.
- Actuator designation and marking (see technical data sheets):
The actuator type, size, operating pressure, output torque, direction of rotation, spring action, operating temperature and type of connections/interfaces are determined by designation.
- All AIR TORQUE actuators are supplied with an identification label showing the serial number and all necessary information on use, service, operation and product designation. Where applicable, the label indicates the classification according to ATEX Directive 94/9/EC.



4. OPERATING FUNCTION AND DIRECTION OF ROTATION

The actuator is a pneumatic device for remote operation of industrial valves. The operation (90°, 120°, 135° or 180° rotation) may be activated by different methods:

- Direct mounting of solenoid valve (5/2 for double acting, 3/2 for spring return) to pressure connections 2 and 4, connected to supply and control lines.
- Screwed connection (to pressure connections 2 and 4) with air lines from separate control cabinet. The standard rotation (when port 4 is pressurized or for spring action) is clockwise to close. When port 2 is pressurized, counter-clockwise rotation is obtained.

Air Torque actuators can be supplied with different types of assembly/rotation direction depending on the type of required operation and/or installation, see technical data sheets.

Double Acting operation function (standard rotation type "ST") TOP View

Air supplied to port 2 forces the pistons towards the actuator end caps. A counter-clockwise rotation is achieved. Exhaust air exits from Port 4.

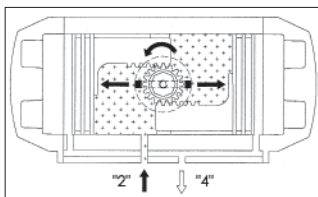

Air supplied to Port 4 forces the pistons inward. A clockwise rotation is achieved. Exhaust air exits from Port 2.

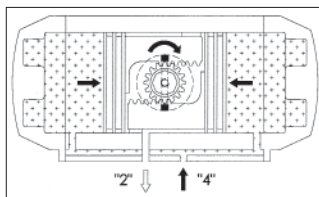

Single Acting operation function (standard rotation type "ST") TOP View

Air supplied to Port "2" forces the pistons toward the actuator end caps, compressing the springs. A counter-clockwise rotation is achieved. Exhaust air exits from Port 4.

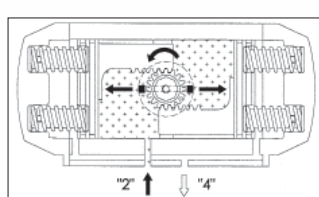

The loss of air pressure (air or electric failure) at Port "2" allows the springs to force the pistons inward. A clockwise rotation is achieved. Exhaust air exits from Port 2.

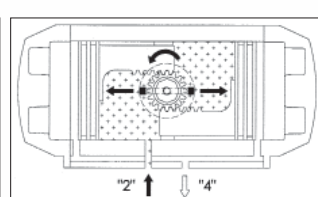

5. ACTUATOR INSTALLATION INSTRUCTIONS

The Air Torque actuator is a pneumatic device for the remote operation of industrial valves. The actuator will operate through 90°, 120°, 135° and 180° rotation permitting the opening and closing of many types of valves up to 180° rotation.

All the necessary technical information to install the actuator correctly and safely onto a valve i.e.: Dimensions, Output torque, Supply pressure, Air volume, Stroke adjustment, Operating time, Operating temperature, Direction of rotation and Weight is stated clearly on the Actuator label, in the catalogue and technical data sheets. Please read all technical information before proceeding with the actuator installation.

5.1 Important safety notice!

- For safety reasons, the actuator must not be pressurized at any time during installation as injury may result.
- The utmost cleanliness is required during air supply connection to the actuator i.e. the connecting pipe thread, fittings and seals must be clean and dirt-free.
- When fitting accessories onto the actuators, assemble them in such a way that the emergency control of the solenoid valve and the top of the drive shaft are easily accessible, should emergency manual operations be required.
- Before fitting onto the valve, make sure that the actuator/valve are correctly orientated, depending upon which direction of rotation is required.
- For spring return actuators, avoid that dangerous and/or corrosive substances in the working environment enter into the external chambers by using adequate filters and/or solenoid valves.
- Remove plugs from actuator air connections during installation and operation. Protect the air connections of actuators not being used immediately.

5.2 Interfaces for actuator control and connections, figure A:

5.3 Assembly of accessories: Solenoid valves and switchboxes, figure B:

- Solenoid valve mounting:
Before mounting a solenoid valve, ensure that the actuator is in its normal position (closed position) with pistons inwards.
For standard rotation type "ST" (clockwise to close) assembly: the groove on the drive shaft or on the position indicator 2 must be horizontal to the longitudinal axis of the actuator in closed position.
Fit the solenoid valve 4 onto the actuator 3 using the provided screws (max. tightening torque see table).
- Switchbox mounting:
Fit the switchbox and bracket 1 onto the actuator 3 using four provided screws (max. tightening torque see table).

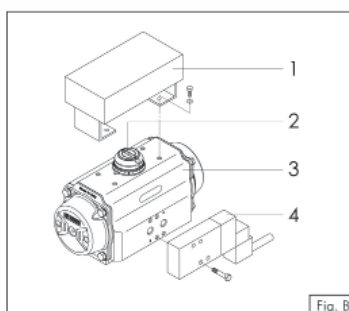
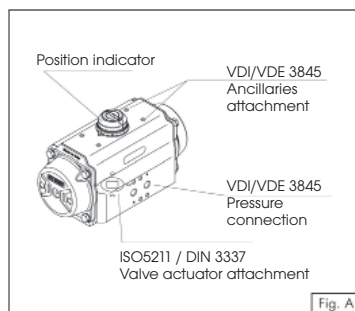

Tightening torque table:

M.	Nm
M5	5 -> 6
M6	10 -> 11
M8	23 -> 25
M10	48 -> 52
M12	82 -> 86
M14	132 -> 138
M16	200 -> 210
M20	390 -> 410
M24	675 -> 705
M30	1340 -> 1400

5.4 Assembly of valve figure C:

Before proceeding with the assembly of the actuator onto the valve, be sure that the actuator operates in the desired direction of rotation when pressurized and both actuator / valve are in the correct position.

Important: when using a spring return actuator for a fail safe operation, ensure that when air or electricity failure occurs the direction of rotation is correct for your application.

Fit the actuator 3 onto the valve 5. It is possible to assemble the valve onto the actuator in two ways:

- Direct-mount: fit the stem of the valve 5 directly into the female connection of the actuator 3 and bolt together through the valve ISO pad (max. tightening torque see table).
- Bracket-mount: mounting with a bracket 6 and coupling 7, the bracket is bolted to the actuator / valve to join them together and the coupling is used to connect the actuator output drive to the valve stem (max. tightening torque see table).

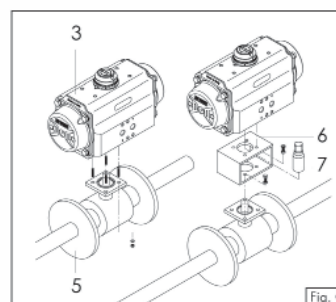



6. MAINTENANCE INSTRUCTION

With the information given below, AIR TORQUE provides the end user with all the required information necessary for maintenance. Under normal conditions, the actuator requires only periodic observation to ensure proper operation.

Maintenance (disassembly, maintenance and rebuilding) of AIR TORQUE actuators is allowed only to AIR TORQUE personnel or properly instructed personnel. In case of controversy the product guarantee will expire! Spare kits for maintenance are available to replace all seals and bearings (soft parts indicated into the table), that may be necessary between 300.000 and 1.000.000 cycles depending on operating and environmental conditions and actuator size.

6.1 DRAWING WITH ITEMIZED COMPONENTS AND RECOMMENDED SPARE PARTS

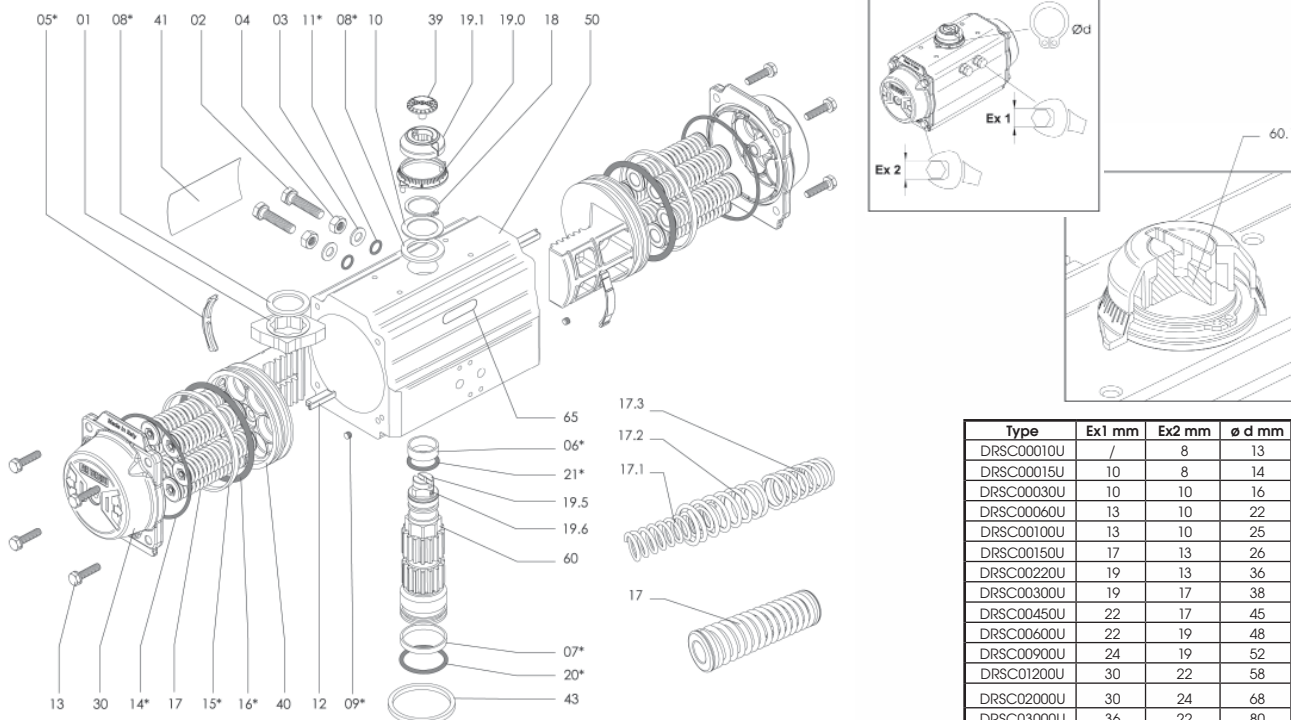

Type	Ex1 mm	Ex2 mm	ø d mm
DRSC00010U	/	8	13
DRSC00015U	10	8	14
DRSC00030U	10	10	16
DRSC00060U	13	10	22
DRSC00100U	13	10	25
DRSC00150U	17	13	26
DRSC00220U	19	13	36
DRSC00300U	19	17	38
DRSC00450U	22	17	45
DRSC00500U	22	19	48
DRSC00900U	24	19	52
DRSC01200U	30	22	58
DRSC02000U	30	24	68
DRSC03000U	36	22	80
DRSC04000U	46	24	85
DRSC05000U	46	24	90

Part	Quantity	Note	Part Description
1	1	not for DRSC00010U	OCTI-CAM (Stop arrangement)
2	2	not for DRSC00010U	Stop cap screw
3	2	not for DRSC00010U	Washer
4	2	not for DRSC00010U	Nut (Stop screw)
05*	2		Bearing (Piston back)
06*	1		Bearing (Pinion top)
07*	1		Bearing (Pinion bottom)
08*	2	1 piece for DRSC00010U	Thrust bearing (Pinion)
09*	2	not for DRSC05000U	Plug
09.1*	2		O-Ring for DRSC05000U
10	1		Thrust washer (Pinion)
11*	2	not for DRSC00010U	O-Ring (Stop screw)
12	2	not for DRSC00010U	Piston guide
13	8/12/16	(A)	Cap screw (End cap)
14*	2		O-Ring (End cap)
15*	2		Bearing (Piston head)
16*	2		O-Ring (Piston)
17	min.5/max.12	for DRSC00030U-DRSC05000U	Spring (Cartridge)
17.1	max.2	not for DRSC00030U-DRSC05000U	Spring for DRSC00010U + 00015U
17.2	max.2	not for DRSC00030U-DRSC05000U	Spring for DRSC00010U + 00015U

Part	Quantity	Note	Part Description
17.3	max.2	not for DRSC00030U-DRSC05000U	Spring for DRSC00010U and DRSC00015U
18	1		Spring clip (Pinion)
19	1	not for DRSC00010U	Position indicator for DRSC00015U + 00030U
19.0	1		Graduated ring
19.1	1	not for DRSC00015U-DRSC00030U	Position indicator
19.5	1	not for DRSC00010U-DRSC00030U	Top adaptor
19.6	2	not for DRSC00010U-DRSC00030U	Hex. socket screw (Top adaptor)
20*	1		O-Ring (Pinion bottom)
21*	1		O-Ring (Pinion top)
30	2		End cap
39	1		Cap screw (Indicator)
40	2		Piston
41	1		Actuator identification label
42	2		End cap label
43	1		Spigot (only on request)
50	1		Body
60	1		Drive shaft
60.1	1	only for type „E“ and „EC“	Integral drive shaft
65	1		Plastic insert

*Suggested SPARE PARTS for maintenance; Notes: (A) 12 pieces for type DRSC03000U/DRSC04000U, 16 pieces for type DRSC05000U

6.2 DISASSEMBLY

When disassembly of actuator is required for maintenance, firstly remove the actuator from the valve. Before performing any disassembly operations it is important to verify that the actuator is not pressurised.

Always use caution and double check that the ports 2 and 4 are vented and are free from any accessory and/or device. When the actuator is a spring return unit, make sure that the actuator is in the failed position and with pistons completely inwards before disassembling.



A. Removal of position indicator and graduated ring (Part N° 19,19.0,19.1), figure 01:

- Remove cap screw (39) if fitted.
- Lift position indicator (19 or 19.1) off shaft, it may be necessary to pry gently with a screwdriver.
- Lift, if necessary, the graduated ring (19.0) off the body, it may be necessary to pry gently with a screwdriver.

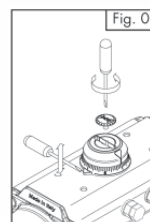

B. Removal of stop cap screws (Part N° 02), figure 02:

- Remove both stop cap screws together with nut (04) and washer (03).
- Remove stop screw o-rings (11) and discard if replacing all soft parts.

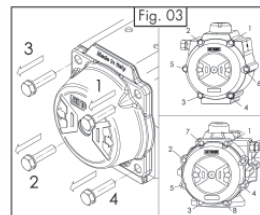
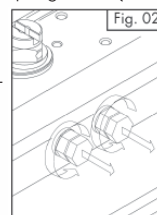

C. End caps disassembly (Part N° 30), figure 03:

- End caps disassembly for spring return actuators (disassemble one end cap at a time).
Unscrew the end cap bolts (13) in the sequence shown in figure 03, until the end-caps are free from springs force (for AT045U and AT051U 20-23 turns of the screws, for AT101U to AT801U 4-5 turns of the screws).

Then completely unscrew the screws and remove the end-cap and the springs.
If there is still force on the end-caps after unscrewing as indicated above, this may indicate that spring cartridge is damaged or that the pistons are not completely closed, so any further disassembly should be discontinued.

Further disassembly of the end caps may result in injury.

- End caps disassembly for double acting actuators (disassemble one end cap at a time)
Unscrew the end cap bolts (13) in the sequence shown in figure 03, until the screws are completely unscrewed and the end caps are free.
- Remove the o-rings (14) using a screwdriver. Discard soft parts if replacing.
- Only for actuators with adjustment 50% or 100%, remove the nut 04R, the washers 03R and o-rings 11R and discard soft parts if replacing.

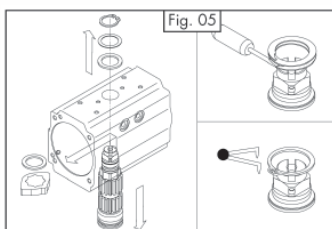

D. Pistons disassembly (Part N° 40), figure 04:

- Holding the body (50) in a vice or similar device, rotate the drive shaft (60) until the pistons (40) are released.
Caution: air pressure should not be used to remove the pistons from the body.
- Remove o-rings (16) using a screwdriver. Remove the piston back (05) and piston head (15) bearings.
- Discard bearings when replacing all soft components.

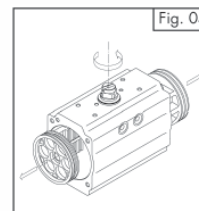

E. Drive shaft disassembly (Part N° 60), figure 05:

- If necessary, remove the graduated ring (19.0) with a screwdriver, remove the spring clip (18) using snap-ring pliers or screwdriver for spiral rings, remove the thrust washer (10) and the external thrust bearing (08).

Apply downward force to top of drive shaft (60), until it is partially out of the bottom of the body when it is possible to remove the internal thrust bearing (08) and the octi-cam (01), then push the pinion (60) completely out of the body. If pinion is not easily removed, gently tap the top of the shaft with a plastic hammer.

- Remove top (06) and bottom (07) pinion bearings and top (20) and bottom (21) pinion o-rings.
- Discard bearings (06) and (07), internal and external thrust washer (08) and o-rings (20) and (21) if replacing the soft components.

All the components disassembled and not replaced will have to be cleaned and inspected for wear and before reassembly, if necessary, also replace the plugs (09).

6.3 ASSEMBLY:

Prior to assembly, ensure that:

- all the components are perfectly clean and in good condition.
- the spare parts and the lubricant used are suitable for the operating temperature of the actuator (see Air Torque technical data sheets).
- Note: The lubricants suitable for the various operating temperatures (Standard, HT and LLT actuators) are available in Air Torque. Only for "standard" actuators, for temperature from -40°C (-40°F) to +80°C (+176°F), it is possible to use lubricant Dow Corning type Molykote® G-2003.

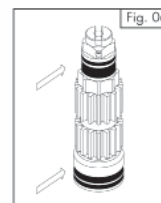

A. Drive shaft assembly (Part N° 60), figures 06, 07 and 07A:

- Install top (06) and bottom (07) bearings, grease and insert the bottom (20) and top (21) pinion o-rings onto the shaft.
- Grease the outside surface of the drive shaft as shown in figure 06.
- Insert partially the drive shaft (60) in the body (50), install octi-cam (01) in the correct position (for standard assembly or for lock-out) as shown in figures 07 and 07A, related to the bottom and top of the drive shaft and the rotation of the actuator when energised. Install the internal thrust bearing (08). Insert completely the drive shaft in the body.
- Fit external thrust bearing (08), thrust washer (10) and then external spring clip (18) using snap ring pliers or screwdriver for spiral rings.

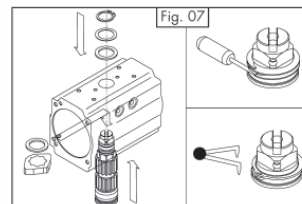

B. Pistons assembly (Part N° 40), figures 08, 09, 10 and 11:

- Grease and install o-rings (16), piston back (05) and piston head (15) bearings.
- Grease the internal surface of the body (50) and the piston (40) rack teeth.
- Insert the female connection of the drive shaft (60) in a properly fixed coupling.
- Ensure that the octi-cam is in the right position as shown in figure 09.
- For standard rotation assembly type "ST" (clockwise to close), rotate the body (50) about 40-45° clockwise from top view, as shown in figure 10.
- Insert and press the two pistons (40) simultaneously inside the body (50) until the pistons are engaged, then rotate the body anticlockwise from top view until the stroke is completed.
- Ensure that with pistons completely closed, the rotation obtained referred to the axis of the body is about over 0° for models AT051U - AT801U (0,5° over 0° for AT045U) and that the dimension "A" on both sides is the same as shown in figure 11.

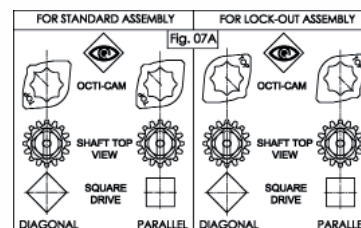



C. End cap (Part N° 30) assembly, figures 12, 13 and 14:

- Assemble one end cap at a time.
- Lubricate the body.
- For spring return actuators, insert the springs in each end cap according to the desired configuration, as shown in figure 12 and related tables. For models DRSC00030U -> DRSC5000U insert spring cartridges as shown in figure 13.
- Fit end cap o-ring seal (14) into the groove on both end caps.
- Fit end caps onto the body (50), verifying that the o-ring remains in the groove.
- Only for actuators with 50% or 100% stroke adjustment, ensure that the adjustment screws 221G/222G are completely screwed into the end-cap.
- Insert the cap screws (13) and tighten each only partially. Complete tightening by making 1-2 turns for each screw in the sequence shown in figure 14 until tightening is completed. See the table for screw tightening torque.

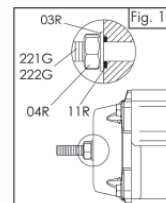
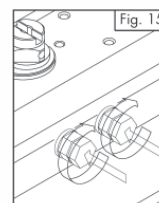
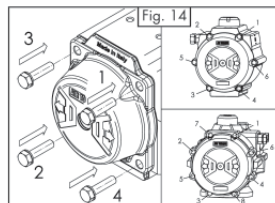
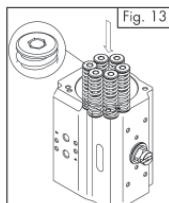
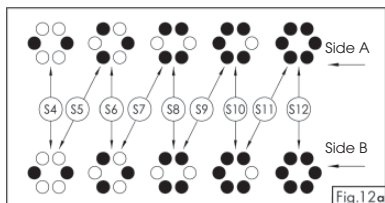
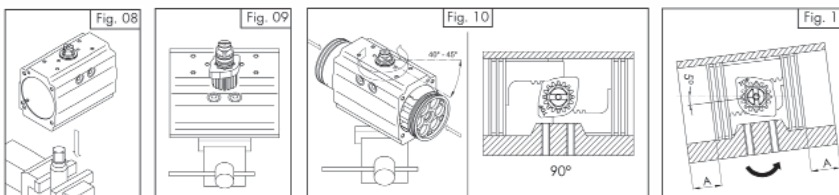

D. Assembly of stop cap screws (Part 02) and stroke adjustment for models DRSC00015U -> DRSC5000U, figures 15 and 16:

- Fit the stop cap screws (02) in the body.
- Stroke adjustment for actuators with standard type "ST" rotation / assembly (clockwise to close).
Stroke adjustment in close position: with the actuator in close position 0°, screw or unscrew the right (from top view) stop cap screw until the desired stop position is achieved. Then tighten the stop adjustment nut (04) to lock it in place.
Stroke adjustment in open position: with the actuator in open position 90°, screw or unscrew the left (from top view) stop cap screw until the desired stop position is achieved. Then tighten the stop adjustment nut (04) to lock it in place.
For spring return actuators, it could be necessary to make rotation tests to verify the correct stroke adjustment in open position.
- Only for actuators with adjustment 50% or 100%, fit on end-cap adjustment screws 221G/222G the o-rings 11R, the washers 03R and the nuts 04R.
To adjust the stroke in open position: with the actuator in partially or totally open position, screw or unscrew the end-cap adjustment screw 221G/222G until the desired position is achieved.
It is important that the two end-cap adjustment screws are both in contact with the pistons. Then lock the nuts 04R.

E. Assembly of graduated ring and position indicator (Part N° 19,19.0,19.1), figures 17,18 and 19:

- Fix the graduated ring (19.0) to the body.
- If necessary, correctly position the "Top Adaptor" (19.5) and lock it with the proper screws (19.6).
- Insert the indicator (19 or 19.1) making sure that it indicates the correct actuator position.
- Screw the indicator screw (39) if assembled.

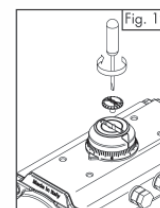
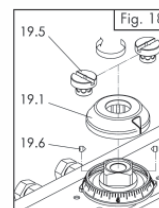
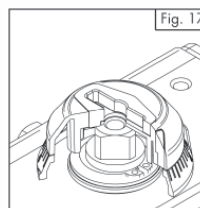

Spring set configuration of SC/SO00010U and SC/SC00015U:

Tab.01: Spring set configuration DRSC00010U

Spring Set	Side B	Side A
	DRSC00010U Spring type	DRSC00010U Spring type
S1-1	1 (green)	1 (green)
S1-2	1 (green)	2 (red)
S2-2	2 (red)	2 (red)
S2-3	2 (red)	3 (black)
S3-3	3 (black)	3 (black)

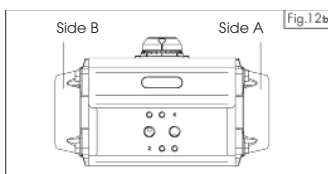

Tab.02: Spring set configuration DRSC00015U

Spring Set	Side B		Side A	
	DRSC00015U Internal spring type	DRSC00015U External spring type	DRSC00015U Internal spring type	DRSC00015U External spring type
S1	1 (green)	—	—	2 (black)
S2	—	2 (black)	—	2 (black)
S3	—	2 (black)	—	3 (red)
S4	—	3 (red)	—	3 (red)
S5	—	3 (red)	1 (green)	2 (black)
S6	1 (green)	2 (black)	1 (green)	2 (black)
S7	1 (green)	2 (black)	1 (green)	3 (red)
S8	1 (green)	3 (red)	1 (green)	3 (red)

7. STORAGE INSTRUCTIONS

- If the actuator is not for immediate use, the following precaution must be taken for storage:
- Store the actuator in a clean and dry environment and at temperature between -20°C (-4°F) and +40°C (+104°F).
- It is recommended that the actuator be stored in its original box.
- Do not remove the plastic plugs on air supply ports.

8. LIFTING and HANDLING

It is recommended to lift the actuators with proper, adequate and permitted systems in relation to the actuator weight and by following the ruling laws in terms of safety and health protection. The weight of the actuators is indicated on the Air Torque catalogue and on the related technical data-sheets. During the lifting and the handling of the actuators, it is recommended to avoid clashes and/or accidental falls in order to avoid irreparable damages to the actuators and to compromise the functionality. Contact Air Torque for any information and technical data-sheets.

9. NOTES regarding the FLANGE CONNECTION

Extract from the standard DIN ISO 5211:
The torque values in the following table show the maximum torques which are allowed to be transmitted by the flange connection:

Flange	Md max.all. (Nm)	Flange	Md max.all. (Nm)	Flange	Md max.all. (Nm)
F03	32	F10	500	F25	8 000
F04	63	F12	1 000	F30	16 000
F05	125	F14	2 000		
F07	250	F16	4 000		



COMPANY PROFILE



AIR TORQUE

PNEUMATISCHE STELLANTRIEBE

Name of company:	AIR TORQUE GmbH
Address:	AIR TORQUE GmbH Im Katzentach 16-18 76275 Ettlingen Tel.: 07243-5934-0 Internet: http://www.airtorque.de Fax: 07243-5934-34 e-Mail: info@airtorque.de
Foundation:	1991 – HRB 1908 E
Staff:	12
Manager:	Dipl.-Ing. Mark Schmidt Dipl.-Ing. Lorenz Stolzenberg
Products:	Pneumatic part turn actuators Double acting and single acting actuators Torque: - Double acting actuators from 7,3 Nm to 10007 Nm at 6 bar air pressure - Single acting actuators from 8,1 Nm to 4068 Nm at 6 bar air pressure Turning range: 90° - 120° - 135° - 180°
Capacity:	6.000 Actuators/Month
Applied standards and regulations:	ISO 5211 DIN 3337 VDI/VDE 3845 NF E 29 - 409
Quality assurance of the products:	Manufactured to a quality system assessed and approved to ISO 9001 (production Italy) Lloyd's Register of Approval Certificate No: LRC 160122
Application:	Part turn actuators are used for automatic operation of valves, which purpose is to reduce, cut off or bypass a stream of material with adjustable cross-sections



REFERENCES



AIR TORQUE

PNEUMATISCHE STELLANTRIEBE



AIR TORQUE Deutschland GmbH
 Im Katzentach 16-18
 76275 Ettlingen
 certified acc. to DIN EN ISO 9001:2000

Phone +49-7243-5934 0
 Fax +49-7243-5934 34
 Email info@airtorque.de
 Internet www.airtorque.de

Company

Location

ABB GENEVA	Switzerland
AGIP	Galliano
AIR-LIQUIDE	Germany, France
AKZO	Elsterberg, Germany
AKZO	Holland
BASF AG	Antwerpen
BASF AG	Ludwigshafen, Germany
BASF AG	Schwarzheide, Germany
BAYER AG	Bitterfeld, Germany
BAYER AG	Indonesia
BOEHRINGER	Ingelheim, Germany
BSL Olefinverbund GmbH	Leipzig, Germany
CASELA AG	Frankfurt, Germany
CIBA-GEIGY AG	Grenzach, Germany
DEGUSSA AG	Rheinfelden, Germany
DOW Agrosociences	Drusenheim, France
DOW Benelux	Terneuzen, Holland
DOW Deutschland	Stade, Germany
DOW Deutschland	Rheinmünster, Germany
DOW Deutschland	Ahlen, Germany
DOW Izolan	Vladimir, Russia
DOW Olefinverbund	Schkopau, Germany
DOW Wolff	Bomlitz, Germany
DSM	Holland

Company

Location

DUPONT	England
ELF Atochem	Leuna, Germany
ELF Tanklager	Hartmannsdorf, Germany
ENEL	Italy
FASERWERK Kehlheim	Kehlheim, Germany
FLOURDANIEL Eng.	South Africa
HAARMANN & REIMER	Holzminden, Germany
HENKEL KGaA	Düsseldorf, Germany
HIMONT	Italy
HOECHST AG	Frankfurt, Germany
HOECHST AG	Gersthofen, Germany
HOFFMANN - LA ROCHE	Grenzach, Germany
JOHN BROWN Eng.	Holland
MANNESMANN DEMAG	Deutschland
MIBRA Tagebau	Proven, Germany
NESTLE I.C.I. ZENICA	England
NISSAN CARS	Japan
PANTOCHIM	Belgium
RHONE POULENC RORA	England
SACHTLEBEN Chemie	Duisburg, Germany
SAMSON AG	Frankfurt, Germany
SOLVAY	Belgien
TOYOTA CARS	Japan
WACKER Chemie	Burghausen, Germany

Air Torque GmbH

Im Katzentach 16-18 · DE - 76275 Ettlingen
 Tel.: +49 (0)7243 59 34-0 · Fax : +49 (0)7243 59 34-34
 info@airtorque.de · www.airtorque.de

Modifications reserved. Date 11.2011.
 No guarantee for accuracy.
 Older data sheets are invalid.